

KINTEK®

HSK TOOLHOLDER AND ACCESSORIES

MANDRINI HSK E ACCESSORI



07



www.kintek.it

HSK TOOLHOLDER AND ACCESSORIES

MANDRINI HSK
E ACCESSORI 

HSK STEILKEGELAUFNAHMEN
UND ZUBEHÖR 

MANDRINS HSK
ET ACCESSOIRES 

ОПРАВКИ HSK, ЗАПАСНЫЕ
ЧАСТИ И ПРИНАДЛЕЖНОСТИ 

HSK 刀柄及附件 

07

■ DIN 69893 A+C	pagg. 190-213
■ DIN 69893 E	pagg. 214-219
■ DIN 69893 F	pagg. 220-227
■ HSK ACCESSORIES	pagg. 228-229



DIN 69893 A+C

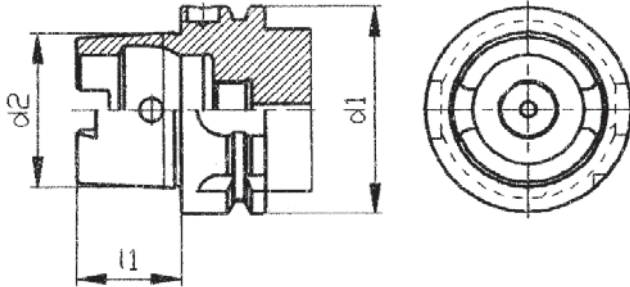

TABLE OF DIMENSIONS ACCORDING TO DIN 69893 STANDARD
TABELLE DER ABMESSUNGEN
UND DER FORMEN NACH DIN 69893
ТАБЛИЦА РАЗМЕРОВ ПО СТАНДАРТУ DIN

TAVOLA RIASSUNTIVA DELLE GRANDEZZE
E DELLE FORME SECONDO DIN 69893
TABLE DE DIMENSIONS SUIVANT DIN 69893
根据 69893 标准的尺寸表

DIN 69893 A+C

HSK A



HSK C

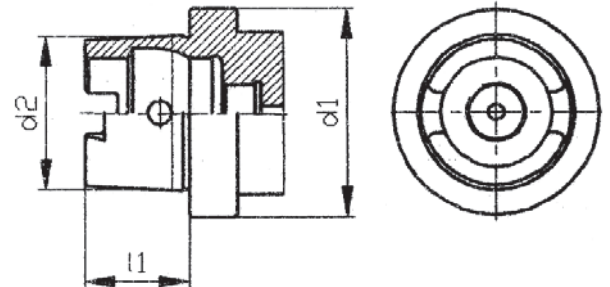

HSK A / C / E

d1 Nominal dia.	d2 Taper dia.	l1 Taper length
32	24	16
40	30	20
50	38	25
63	48	32
100	75	50
125	95	63

HSK E

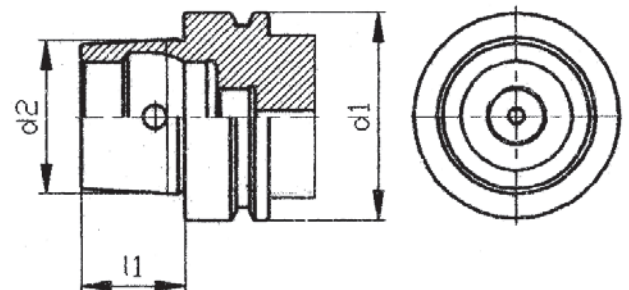

HSK B

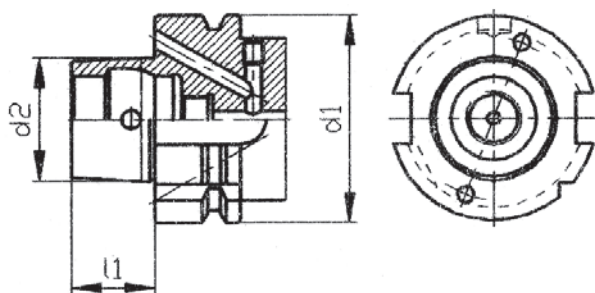

HSK D

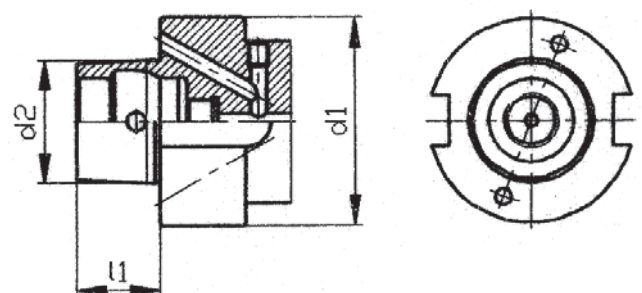

HSK B / D / F

d1 Nominal dia.	d2 Taper dia.	l1 Taper length
40	24	16
50	30	20
63	38	25
100	60	40

HSK F

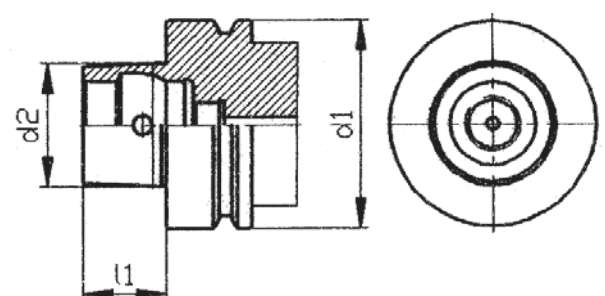

TAPER SHANKS DATA SHEET DATI TECNICI CONI D'ATTACCO
 TECHNISCHE DATEN DER STEILKEGELWERKZEUGE DONNES TECHNIQUES QUEUE D'OUTILS
 КОНСТРУКТИВНЫЕ РАЗМЕРЫ 锥柄数据表

DIN 69893 A+C

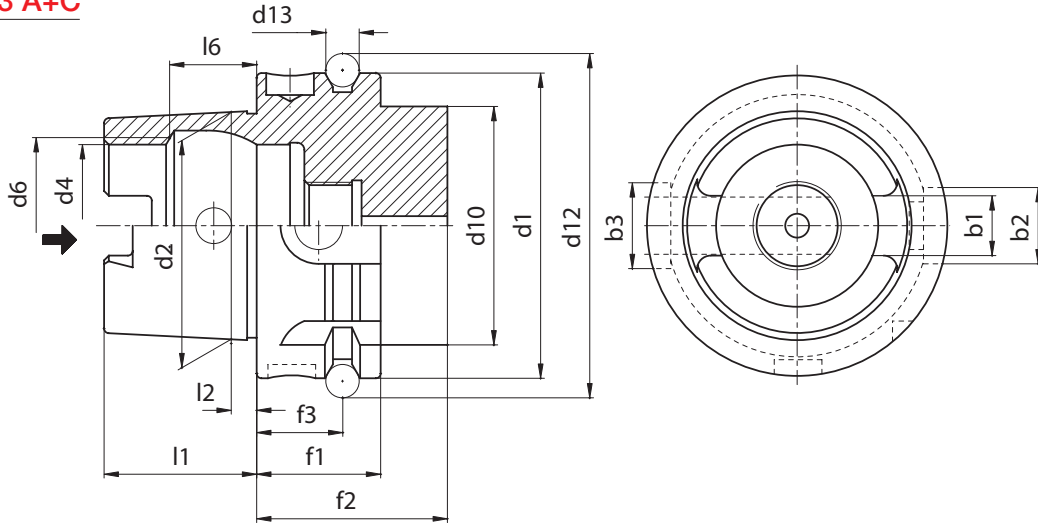

	HSK 32	HSK 40	HSK 50	HSK 63	HSK 100	HSK 125
b1	7,05	8,05	10,54	12,54	20,02	25,02
b2	7	9	12	16	20	25
b3	9	11	14	18	22	28
d1	32	40	50	63	100	125
d2	24	30	38	48	75	95
d4	17	21	26	34	53	67
d6	19	23	29	37	58	73
d10	26	34	42	53	88	111
d12	37	45	59,3	72,3	109,75	134,75
d13	4	4	7	7	7	7
f1	20	20	26	26	29	29
f2	35	35	42	42	45	45
f3	16	16	18	18	20	20
l1	16	20	25	32	50	63
l2	3,2	4	5	6,3	10	12,5
l6	8,92	11,42	14,13	18,13	28,56	36,27

FORM A

- Used on machining centres, milling machines, turning machines, special machines with automatic tool change.
- Central, axial coolant supply through coolant tube.
- Torque transmission via two key slots at end of taper.
- Two slots on collar for tool magazine, location edge. Hole for data carrier DIN 69893 in collar.

FORMA A

- Usato su centri di lavoro, fresatrici e macchine speciali con cambio utensile automatico.
- Adduzione refrigerante centrale.
- Coppia trasmessa con due chiavette al fondo della sede conica.
- Tacche di riferimento sulla flangia per riferimento posizione tagliente. Foro di predisposizione al sistema di riconoscimento a norme DIN 69893 sull'esterno flangia.

FORM A

- Anwendung für Bearbeitungszentren, Fräsmaschinen, Drehmaschinen, Sondermaschinen mit automatischem Werkzeugwechsel.
- Zentrale, axiale Kühlmittelzufuhr über Kühlmittelrohr.
- Drehmomentübertragung über zwei Mitnehmernuten am Kegellende.
- Zwei Bundnuten für Werkzeugmagazin, Positionskerbe. Bohrung für Datenträger DIN 69893 im Bund.
- Balluffchip

FORME A

- Utilisation sur les centres d'usinage, les fraiseuses, les machines spéciales à changement d'outils automatique.
- Alimentation centrale, axiale du liquide de lubrification par tube d'arrosage.
- Transmission du couple par deux gorges d'entraînement à l'extrémité du cône.
- Deux gorges magasin à outils, entaille de positionnement, perçage pour support de données DIN 69893 dans l'épaulement.

ИСПОЛНЕНИЕ А

- Применяются в обрабатывающих центрах, фрезерных станках для тяжелой обработки, токарных станках.
- Усиленный фланец.
- Подача СОЖ либо боковая - через отверстия во фланце, либо центральная - через центральный канал оправки.
- Передача крутящего момента осуществляется через шпоночные пазы на конце конуса.
- На фланце находятся два паза для хранения оправки в инструментальном магазине, а также отверстие для датчика позиционирования.

FORMA A

- 用于机械加工中心、铣床、车床及配备自动更换工具的专用机器。
- 通过冷却剂管道向中心或轴来供应冷却剂。
- 通过在锥体末端的两个键槽进行扭矩传输。
- 在工具库的位置边缘的颈圈上有两个槽，它们是数据传送孔。

CONE'S TOLERANCE TOLLERANZA DEL CONO
KEGELSCHAFTTOLERANZEN TOLERANCE DU CONE
ТОЧНОСТЬ КОНУСА 锥体误差

DIN 69893 A+C

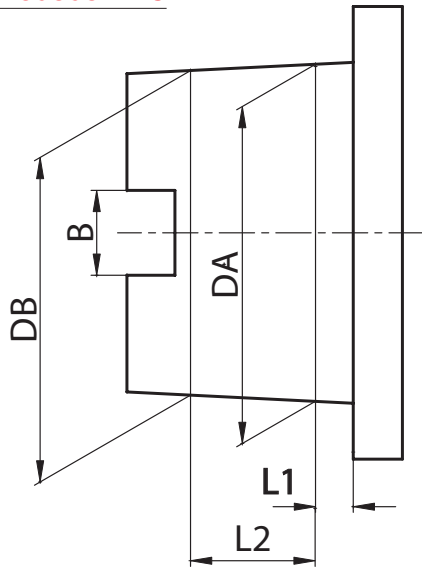

HSK	L1	L2	D.A.	D.B.	B (only type A+C)
32 A+C	3,2	7,3	24 +0.005 +0.007	23,27 +0.003 +0.005	7.05 +/- 0.04
40 A+C+E	4	9,5	30 +0.005 +0.007	29,05 +0.003 +0.005	8.05 +/- 0.04
40 B+D	3,2	7,3	24 +0.005 +0.007	23,27 +0.003 +0.005	-
50 A+C+E	5	11	38 +0.006 +0.009	36,9 +0.003 +0.006	10.54 +/- 0.04
50 B+D+F	4	9,5	30 +0.005 +0.007	29,05 +0.003 +0.005	-
63 A+C+E	6,3	14,7	48 +0.007 +0.011	46,53 +0.003 +0.007	12.54 +/- 0.04
63 B+D+F	5	11	38 +0.006 +0.009	36,9 +0.003 +0.006	-
100 A+C	10	24	75 +0.009 +0.015	72,6 +0.003 +0.009	20.02 +/- 0.04
100 B+D	8	19	60 +0.008 +0.013	58,1 +0.003 +0.008	-
125 A+C	12,5	30,5	95 +0.008 +0.013	91,9 +0.003 +0.008	25,02 +/- 0,04



KINTEK TOOLHOLDERS

All KINTEK toolholders are manufactured according to DIN norms.
(these norms provide the same classes of tolerance for the attachment DIN69893 A+C, B+D, E, F)

COLLET CHUCK'S RUNOUT ACCURACY

The norm DIN 69882-6 permits a runout error of 0,005 mm. for DIN6499/ISO15488 collet chucks.

SHELL END MILL ADAPTOR'S RUNOUT ACCURACY

Our shell end mill adaptors meet the requirements of the norm DIN 69882-2, which prescribes for diameters \varnothing 16,22,27,32 a runout accuracy of 0,01

WELDON END MILL HOLDER'S RUNOUT ACCURACY

According to norm DIN 69882-4 Weldon end mill holders have to meet the following requirements: Bore: H5 / Runout accuracy: 0.005.

CONSTRUCTIVE FEATURES

- Manufactured with casehardening Steel.
- Casehardened with depth 0,4 - 0,5 mm
- Hardened-Tempered
- Hardness HRC 58+-2, Strength 800-1000 N/mm2
- Black oxidized
- Internal and external grinding finish of the cone
- Grinding finish on the front side and on the thread of collet nuts.
- Tested 100% with certified measuring instruments and supplied with balancing certificate



MANDRINI KINTEK CON ATTACCO HSK

Tutti i mandrini portautensili KINTEK vengono prodotti secondo le normative DIN
(dette normative prevedono le stesse classi di tolleranza per gli attacchi DIN69893 A+C, B+D, E, F)

COASSIALITÀ PORTAPINZA

La normativa DIN 69882-6, ammette un'errore massimo di 0,005 mm. per i portapinze DIN6499/ISO15488

COASSIALITÀ PORTAFRESE FISSI E COMBINATI

I portafrese fissi e combinati rispondono ai criteri prescritti dalla norma DIN 69882-2 la quale prevede per i \varnothing 16,22,27,32 una coassialità di 0,01

COASSIALITÀ PORTAFRESE WELDON

Secondo la normativa DIN 69882-4 il portafrese WELDON deve rispondere ai seguenti requisiti: Foro: H5 / Coassialità: 0.005.

DATI COSTRUTTIVI

- Costruiti in acciaio da cementazione legato.
- Cementati con profondità 0,4 - 0,5 mm
- Temprati-rinvenuti
- Durezza HRC 58 +- 2 resistenza 800-1000 N/mm2
- Bruniti
- Finitura di rettifica interna, esterna del cono
- Rettifica parte anteriore e nelle filettature delle ghiera chiudipinza
- Collaudati 100% con strumenti di misura certificati e forniti con certificato di bilanciatura.



STEILGEKELAUFNHMEN HSK

Alle KINTEK - Steilgekelaufnahmen werden nach den DIN - Normen angefertigt.
(Diese Normen sehen die gleichen Toleranzklassen für die DIN 69893 A+C, B+D, E, F Aufnahmen vor)

SPANNZANGENAUFNAHME RUNDLAUFGENAUIGKEIT

Die DIN69882-6 Norm schreibt eine Rundlaufgenauigkeit zwischen Aussenkegel und Innenkegel / Spannanzengensitz für die DIN6499/ISO15488- Spannanzenaufnahmen von 0,005 vor.

AUFSTECKFRÄSDORNE - RUNDLAUFGENAUIGKEIT

Kintek-Aufsteckfräsdorne entsprechen der DIN 69882-2 Norm, die für die \varnothing 16,22,27,32 eine Rundlaufgenauigkeit von 0,01 vorsieht.

WELDON - AUFSTECKFRÄSDORNE - RUNDLAUFGENAUIGKEIT

Nach der DIN 69882-4 Norm muß der Weldon- Aufsteckfräsdorn die folgenden Forderungen aufweisen: Bohrung: H5 / Rundlaufgenauigkeit: 0.005.

KONSTRUKTIONSDATEN

- aus Einsatzstahl angefertigt
- in der Einsatzhärtetiefe von 0,4-0,5 mm
- gehärtet, angelassen
- Härte HRC 58 +- 2, Festigkeit 800-1000 N/mm2
- brüniert
- inneres, äußeres Schleifen des Kegels
- Schleifen der Vorderseite und am Gewinde der Spannanzengemutter
- 100% durch zertifizierte Meßinstrumente geprüft und mit Wuchtungsprotokoll geliefert

CONE'S TOLERANCE TOLLERANZA DEL CONO
 KEGELSCHAFTTOLERANZEN TOLERANCE DU CONE
 ТОЧНОСТЬ КОНУСА 锥体误差

DIN 69893 A+C

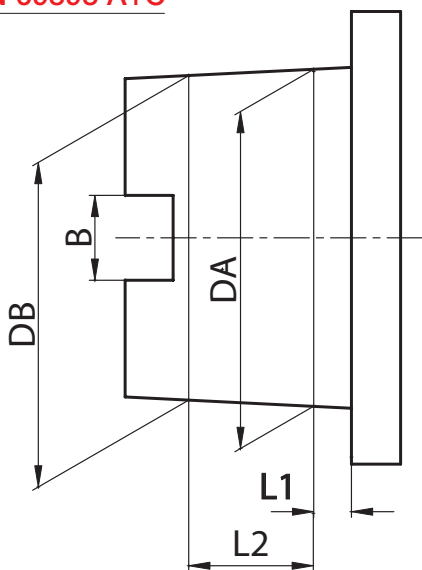

HSK	L1	L2	D.A.	D.B.	B (only type A+C)	
32 A+C	3,2	7,3	24	+0.005 +0.007	23,27 +0.003 +0.005	7.05 +/- 0.04
40 A+C+E	4	9,5	30	+0.005 +0.007	29,05 +0.003 +0.005	8.05 +/- 0.04
40 B+D	3,2	7,3	24	+0.005 +0.007	23,27 +0.003 +0.005	-
50 A+C+E	5	11	38	+0.006 +0.009	36,9 +0.003 +0.006	10.54 +/- 0.04
50 B+D+F	4	9,5	30	+0.005 +0.007	29,05 +0.003 +0.005	-
63 A+C+E	6,3	14,7	48	+0.007 +0.011	46,53 +0.003 +0.007	12.54 +/- 0.04
63 B+D+F	5	11	38	+0.006 +0.009	36,9 +0.003 +0.006	-
100 A+C	10	24	75	+0.009 +0.015	72,6 +0.003 +0.009	20.02 +/- 0.04
100 B+D	8	19	60	+0.008 +0.013	58,1 +0.003 +0.008	-
125 A+C	12,5	30,5	95	+0.008 +0.013	91,9 +0.003 +0.008	25,02 +/- 0,04



MANDRINS KINTEK HSK

Tous les mandrins porte-outils KINTEK sont fabriqués selon les normes DIN (qui prévoient les mêmes classes de tolérance pour les attachement DIN69893 A+C, B+D, E, F)

COAXIALITE' PORTE-PINCE

La norme DIN 69882-6 permet une erreur de 0,005 mm. Maximum pour les porte-pinces DIN6499/ISO15488

COAXIALITE' PORTE-FRAISES FIXES ET COMBINES

Les porte-fraises fixes et combinés suivent les spécifications de la norme DIN 69882-2 qui prévoit pour les diamètres Ø 16,22,27,32 une coaxialité de 0,01

COAXIALITE' PORTE-FRAISES WELDON

Suivant les spécifications DIN 69882-4 les porte-fraises WELDON doivent suivre les conditions suivantes: Trou: H5 / Coaxialité: 0.005.

ELEMENTS DE CONSTRUCTION

- Produits en acier cémenté allié.
- Cémentés avec une profondeur 0,4 - 0,5 mm
- Trempés - Revenus
- Dureté HRC 58 +/- 2 résistance 800-1000 N/ mm2
- Brunis
- Finition de rectification intérieure, extérieure et du cône
- Rectification du cône intérieur et dans le filetage des écrous qui serrent la pince.
- Contrôlés à 100 % avec des instruments de mesure certifiés et livrés avec un certificat d'équilibrage.



ОПРАВКИ KINTEK

Все оправки Kintek произведены согласно стандарту DIN.

(Эти нормы обеспечивают тот же класс точности как DIN 6983 A+C, B+D, E, F)

БИЕНИЕ ЦАНГОВЫХ ПАТРОНОВ

В соответствии с нормами DIN 69882-6, допустимое биение составляет 0,005 мм для цанговых патронов по DIN6499/ISO15488.

БИЕНИЕ ОПРАВОК ДЛЯ НАСАДНЫХ ФРЕЗ

Патроны изготовлены в соответствии с требованиями DIN 69882-2, согласно которым биение для диаметров 16-22-27-32-40 составляет 0,01.

БИЕНИЕ ПАТРОНОВ С КРЕПЛЕНИЕМ WELDON

Оправки соответствуют следующим требованиям DIN 69882-4: Точность отверстия: H5 / Биение: 0,005

КОНСТРУКТИВНЫЕ ОСОБЕННОСТИ

- Изготовлены из стали с последующей цементацией
- Цементация на глубину 0,4 - 0,5 мм
- Оправки подвергнуты закалке и отпуску
- Твердость 58 +/- 2 HRC, прочность 800-1000 Н/мм2
- Защитно-декоративное покрытие черного цвета
- Шлифованные внутренняя и внешняя поверхности конуса
- Шлифованный торец и резьба под гайку в цанговых патронах
- Каждая оправка испытана и поставляется с сертификатом о балансировке



KINTEK 刀柄

所有 KINTEK 刀柄均是按照 DIN 标准制造的。

(这些标准规定了与附件 DIN69893 A+C, B+D, E, F 相同级别的误差)。

弹簧夹头的径向跳动精度

DIN69882-6 标准允许 DIN6499/ISO15488 弹簧夹头的径向跳动误差为 0,005 毫米。

平面铣接头的径向跳动精度

我公司的平面铣接头满足 DIN69882-2 标准要求, 该标准规定了直径为 16, 22, 27, 32 的径向跳动精度为 0, 01。

威尔登端铣刀夹具的径向跳动精度

根据 DIN 69882-4 标准规定, 威尔登端铣刀夹具必须要达到下列要求: 孔: H5 / 径向跳动精度: 0.005。

结构特点

- 用表面硬化钢材制造。
- 硬化深度达 0,4 - 0,5 毫米。
- 经过硬化及回火处理。
- 硬度达 HRC 58 +/- 2, 强度达 800-1000 N/平方毫米。
- 黑色氧化。
- 锥体内部及外部表面进行打磨处理。
- 夹头螺母的螺纹正面和上面经过打磨处理。
- 100% 使用经过认证的测量仪器检测, 提供平衡证书。

GREAT ACCURACY - HIGH PRECISION LINE



RUN OUT 5 MICRON at 2,5 times the diameter achieved only by using PRECISION ER collets

The High level of accuracy is achieved either on the NOMINAL DIAMETER or by clamping the tool whose diameter is maximum 0,5 mm smaller than the nominal diameter.



RUN OUT 5 MICRON a 2,5 il diametro garantito esclusivamente tramite pinze ER PRECISE

L'elevata precisione si ottiene o sul DIAMETRO NOMINALE o chiudendo l'utensile con diametro al massimo di 0,5mm inferiore al diametro nominale.



5 MICRON RUNDLAUFGENAUIGKEIT bei 2,5 Mal des Durchmessers nur durch Verwendung von PRÄZISIONS-ER Spannzangen erreicht

Das Erreichen der hohen Genauigkeit erfolgt entweder am NENNDURCHMESSER oder durch das Spannen des Werkzeuges, wessen Durchmesser maximal 0,5 mm kleiner als der Nenndurchmesser ist.



COAXIALITE 5 MICRON à 2,5 fois le diamètre obtenue uniquement en utilisant des pinces ER PRECISE

Le haut niveau de précision est obtenu soit sur le NOMINAL DIAMETER soit en serrant l'outil dont le diamètre est au maximum 0,5 mm inférieur au diamètre nominal.



RUN OUT с 5 до 2,5 MICRON достигается только при использовании цанг PRECISION ER

Высокий уровень точности достигается либо при зажиме НОМИНАЛЬНОГО ДИАМЕТРА, либо путем зажима инструмента, диаметр которого не должен превышать 0,5 мм номинального диаметра.



配合使用高精度 ER 夹头，2.5 倍径 处的跳动精度可达到 5 μ

为达到高精度应夹持名义直径 或者小于名义直径不超过 0,5mm 的工具

ER COLLET CHUCK MANDRINI PORTAPINZA TIPO ER
 SPANNZANGENFUTTER ER TYP MANDRINS A PINCES TYPE ER
 ЦАНГОВЫЕ ПАТРОНЫ ER ER 弹簧夹头

DIN69893 HSKA - DIN 6499

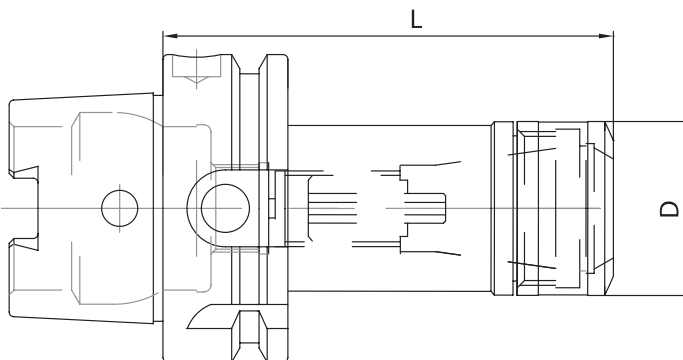
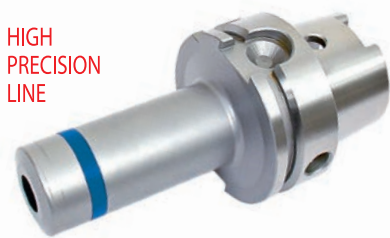
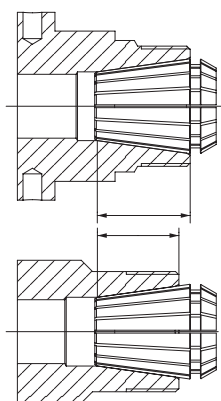

STANDARD

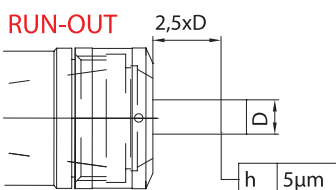

CODE N.	DESCRIPTION	HSK	L	D	ER	G2,5 30000
214-91747	HSK63AH75ER16-HP	63	75	30	16	•
214-91748	HSK63AH75ER25-HP	63	75	40	25	•
214-91749	HSK63AH75ER32-HP	63	75	50	32	•
214-91738	HSK63AH100ER16-HP	63	100	30	16	•
214-91739	HSK63AH100ER25-HP	63	100	40	25	•
214-91740	HSK63AH100ER32-HP	63	100	50	32	•
214-91742	HSK63AH160ER16-HP	63	160	30	16	•
214-91743	HSK63AH160ER25-HP	63	160	40	25	•
214-91744	HSK63AH160ER32-HP	63	160	50	32	•
214-91741	HSK100AH100ER32-HP	100	100	50	32	•
214-91750	HSK100AH160ER25-HP	100	160	40	25	•
214-91746	HSK100AH160ER32-HP	100	160	50	32	•

Accessories
 Accessori
 Zubehör
 Accessoires
 Принадлежности
 零件



WRENCHES FOR NUT SPANNSCHLÜSSEL FÜR SPANNMUTTER
 КЛЮЧИ ДЛЯ СТАНДАРТНЫХ ГАЕК
 CHIAVI PER GHIERA CLES DE SERRAGE POUR ECROU
 标准螺母用扳手

CODE N.	D	D1	ER
816-203069	30	3	16
816-203070	40	4	25
816-203071	50	4	32



COLLETS ER TYPE PINZE TIPO ER
 ER TYP SPANNZANGEN PINCES TYPE ER
 НАБОРЫ ЦАНГ ER ER 类型的夹头

CODE N.	D	L	ER
812-203085	30	18	16
812-203086	40	20,5	25
812-203087	50	23,5	32

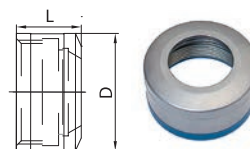

COLLET CHUCK KITS KIT PORTAPINZE
 SPANNFUTTERSATZ JEUX PORTE-PINCES
 НАБОРЫ ОПРАВОК С ЦАНГАМИ 夹头变径套组套



Kit Box: 1 Collet chuck
 + 10 Collets + Wrench
Cassetta Corredo: 1 Portapinze + 10 pinze + chiave
Ausstattungskasten: 1 Spannzangenfutter
 + 10 Spannzangen
 + Spanschlüssel

Boite d'équipement: 1 Porte-pince
 + 10 pinces + Clé de serrage
Набор: из цангового патрона и цанг
套装: 1个弹簧夹刀柄 + 10个夹头+扳手

CODICE ORDINAZIONE ORDER CODE	COMPOSIZIONE COMPOSITION
KIT TC40 ER16 HP	N°1 TC40 H70 ER16 HP + N°10 COLLETS ER16 HP
KIT TC40 ER25 HP	N°1 TC40 H70 ER25 HP + N°10 COLLETS ER25 HP
KIT TC40 ER32 HP	N°1 TC40 H70 ER32 HP + N°10 COLLETS ER32 HP
KIT BT40 ER16 HP	N°1 BT40 H70 ER16 HP + N°10 COLLETS ER16 HP
KIT BT40 ER25 HP	N°1 BT40 H70 ER25 HP + N°10 COLLETS ER25 HP
KIT BT40 ER32 HP	N°1 BT40 H70 ER32 HP + N°10 COLLETS ER32 HP
KIT HSK63 ER16 HP	N°1 HSK63 AH75 ER16 HP + N°10 COLLETS ER16 HP
KIT HSK63 ER25 HP	N°1 HSK63 AH75 ER25 HP + N°10 COLLETS ER25 HP
KIT HSK63 ER32 HP	N°1 HSK63 AH75 ER32 HP + N°10 COLLETS ER32 HP

ER COLLET CHUCK MANDRINI PORTAPINZA TIPO ER
 SPANNZANGENFUTTER ER TYP MANDRINS A PINCES TYPE ER
 ЦАНГОВЫЕ ПАТРОНЫ ER ER 弹簧夹头

DIN 69893 A+C - DIN6499/ISO15488

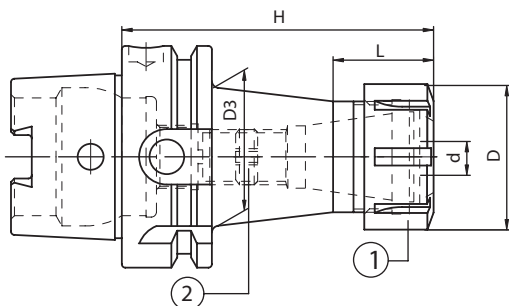

HSK	CODE N.	DESCRIPTION	H	d	D	ER	L	D3	G2,5 30000
63	214-91731	HSK63AH75ER16	75	0,5÷10	32	16	-	-	•
63	214-91733	HSK63AH75ER20	75	1÷13	35	20	-	-	•
63	214-91734	HSK63AH75ER25	75	1÷16	42	25	-	-	•
63	214-91737	HSK63AH75ER32	75	2÷20	50	32	-	-	•
63	214-91735	HSK63AH80ER40	80	3÷30	63	40	-	-	•
63	214-91701	HSK63AH90ER16M	90	0,5÷10	22	16M	-	-	•
63	214-91732	HSK63AH100ER16	100	0,5÷10	32	16	37	31	•
63	214-91729	HSK63AH100ER20	100	1÷13	35	20	37	34	•
63	214-91702	HSK63AH100ER25	100	1÷16	42	25	37	40	•
63	214-91703	HSK63AH100ER32	100	2÷20	50	32	-	-	•
63	214-91704	HSK63AH120ER40	120	3÷30	63	40	-	-	•
63	214-91708	HSK63AH160ER16M	160	0,5÷10	22	16M	57	35	•
63	214-91730	HSK63AH160ER20	160	1÷13	35	20	60	38	•
63	214-91709	HSK63AH160ER25M	160	1÷16	35	25M	68	46	•
63	214-91710	HSK63AH160ER32	160	2÷20	50	32	-	-	•
63	214-91711	HSK63AH160ER40	160	3÷30	63	40	-	-	•

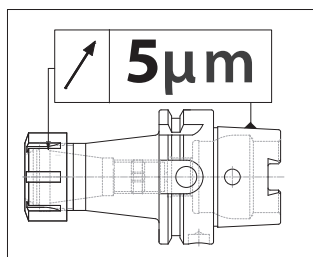

HIGH BALANCED

Spare parts • Componenti • Ersatzteile
 Pièces détachées • Запасные части • 零件

ER	NUT	STOP SCREW
16M	812-203013	811-303119
16	812-203069	811-303119
20	812-203081	811-303120
25M	812-203015	811-303121
25	812-203070	811-303121
32	812-203071	811-303118
40	812-203072	811-303122

Accessories
 Accessori
 Zubehör
 Accessoires
 Принадлежности
 零件



07



ER MINI COLLET CHUCK MANDRINI PORTAPINZA TIPO ER MINI EXTRA SOTTILI
 SPANNZANGENFUTTER ER MINI TYP MANDRINS A PINCES TYPE ER MINI
 ЦАНГОВЫЕ МИНИ-ПАТРОНЫ ER 微型 ER 弹簧夹头

DIN 69893 A+C - **DIN6499/ISO15488**

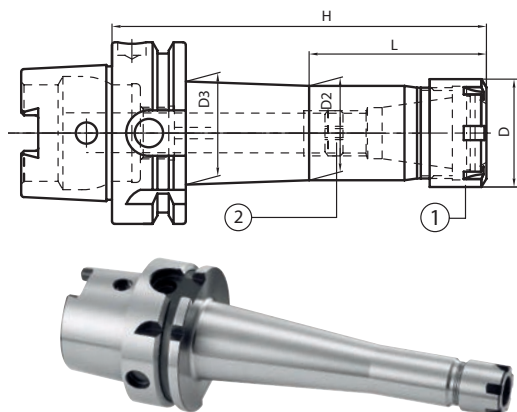

HSK	CODE N.	DESCRIPTION	ER	D	H	L	D2	D3	G2,5 30000 RPM
40	214-91723	HSK40AH70ER11M	11M	16	70	20	14	16	•
40	214-91724	HSK40AH100ER11M	11M	16	100	40	14	20	•
63	214-91715	HSK63AH100ER11M	11M	16	100	40	14	20	•
63	214-91720	HSK63AH100ER16M	16M	22	100	42	20	25	•
63	214-91726	HSK63AH100ER20M	20M	28	100	48	26	30	•
63	214-91717	HSK63AH100ER25M	25M	35	100	-	33	-	•
63	214-91716	HSK63AH160ER11M	11M	16	160	50	14	23	•
63	214-91727	HSK63AH160ER20M	20M	28	160	98	26	31	•
100	214-91718	HSK100AH100ER16M	16M	22	100	47	22	26	•

SLIM LINE

HIGH BALANCED

Spare parts • Componenti • Ersatzteile
 Pièces détachées • Запасные части • 零件

ER	NUT	STOP SCREW
11M	812-203012	811-303081
16M	812-203013	811-303119
25M	812-203015	811-303121

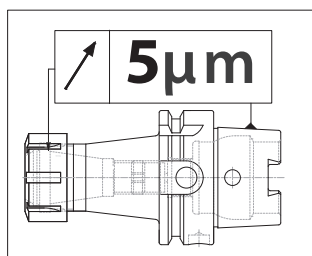

Accessories
 Accessori
 Zubehör
 Accessoires
 Принадлежности
 零件



07

ER COLLET CHUCKS MANDRINI PORTAPINZA TIPO ER
 SPANNZANGENFUTTER ER TYP MANDRINS A PINCES TYPE ER
 ЦАНГОВЫЕ ПАТРОНЫ ER ER 弹簧夹头

DIN 69893 A+C - **DIN6499/ISO15488**

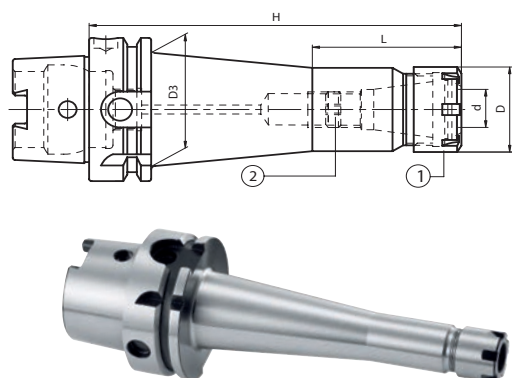

HSK	CODE N.	DESCRIPTION	H	d	D	ER	L	D3	G2,5 30000 RPM
50	214-31734	HSK50AH160ER16M	160	0,5÷10	22	16M	57	28	•
63	214-31736	HSK63AH160ER16M	160	0,5÷10	22	16M	57	28	•
63	214-31737	HSK63AH160ER25M	160	1÷16	35	25M	68	42	•
63	264-31731	HSK63AH160ER16	160	0,5÷10	32	16	57	35	•
63	264-31732	HSK63AH160ER20	160	1÷13	35	20	60	38	•
63	264-31743	HSK63AH160ER25	160	1÷16	42	25	37	42	•
63	214-31720	HSK63AH160ER32	160	2÷20	50	32	-	-	•
63	214-31721	HSK63AH160ER40	160	3÷30	63	40	-	-	•
100	214-31772	HSK100AH160ER16M	160	0,5÷10	22	16M	57	30	•
100	214-31773	HSK100AH160ER25M	160	1÷16	35	25M	68	46	•
100	214-31752	HSK100AH160ER25	160	1÷16	42	25	37	45	•
100	214-31738	HSK100AH160ER32	160	2÷20	50	32	38	53	•
100	214-31739	HSK100AH160ER40	160	3÷30	63	40	40	63	•
125	264-31750	HSK125AH160ER25	160	1÷16	42	25	37	45	•
125	264-31751	HSK125AH160ER32	160	2÷20	50	32	38	53	•
125	264-31752	HSK125AH160ER40	160	3÷30	63	40	40	63	•

Spare parts • Componenti • Ersatzteile
 Pièces détachées • Запасные части • 零件

ER	NUT	STOP SCREW
16M	812-203013	811-303119
20M	812-203014	811-303121
25M	812-203015	811-303121
16	812-203005	811-303119
20	812-203006	811-303120
25	812-203001	811-303121
32	812-203002	811-303118
40	812-203003	811-303122

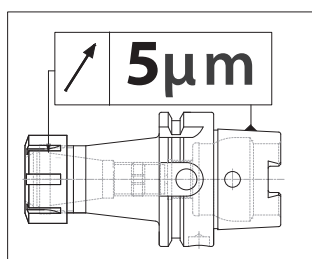

Accessories
 Accessori
 Zubehör
 Accessoires
 Принадлежности
 零件



ER COLLET CHUCKS MANDRINI PORTAPINZA TIPO ER
 SPANNZANGENFUTTER ER TYP MANDRINS A PINCES TYPE ER
 ЦАНГОВЫЕ ПАТРОНЫ ER ER 弹簧夹头

DIN 69893 A+C - DIN6499/ISO15488

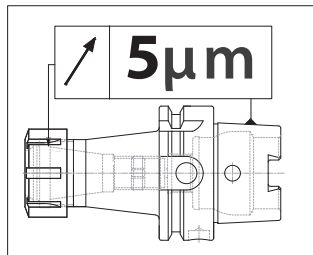
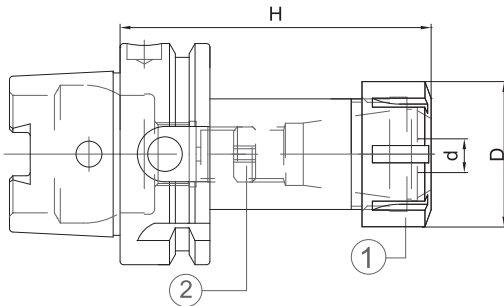

HSK	CODE N.	DESCRIPTION	H	d	D	ER	L	D3	G6,3 20000 RPM
32	214-31740	HSK32AH65ER16M	65	0,5÷10	22	16M	-	-	•
32	214-31741	HSK32AH70ER25M	70	1÷16	35	25M	-	-	•
40	214-31745	HSK40AH60ER16M	60	0,5÷10	22	16M	-	-	•
40	214-31722	HSK40AH70ER16M	70	0,5÷10	22	16M	-	-	•
40	214-31732	HSK40AH120ER16M	120	0,5÷10	22	16M	47	29	•
40	214-31746	HSK40AH65ER25	65	1÷16	42	25	-	-	•
40	214-31702	HSK40AH80ER25	80	1÷16	42	25	-	-	•
40	214-31747	HSK40AH65ER32	65	1÷20	50	32	-	-	•
40	214-31703	HSK40AH100ER32	100	1÷20	50	32	-	-	•
50	214-31723	HSK50AH80ER16M	80	0,5÷10	22	16M	-	-	•
50	214-31705	HSK50AH95ER25	95	1÷16	42	25	-	-	•
50	214-31706	HSK50AH100ER32	100	2÷20	50	32	-	-	•
63	214-31724	HSK63AH90ER16M	90	0,5÷10	22	16M	-	-	•
63	264-31736	HSK63AH75ER16	75	0,5÷10	32	16	-	-	•
63	264-31741	HSK63AH100ER16	100	0,5÷10	32	16	37	31	•
63	264-31737	HSK63AH75ER20	75	1÷13	35	20	-	-	•
63	264-31742	HSK63AH100ER20	100	1÷13	35	20	37	34	•
63	264-31738	HSK63AH75ER25	75	1÷16	42	25	-	-	•
63	214-31707	HSK63AH100ER25	100	1÷16	42	25	37	40	•
63	264-31739	HSK63AH75ER32	75	2÷20	50	32	-	-	•
63	214-31708	HSK63AH100ER32	100	2÷20	50	32	-	-	•
63	264-31740	HSK63AH80ER40	80	3÷30	63	40	-	-	•
63	214-31709	HSK63AH120ER40	120	3÷30	63	40	-	-	•
100	214-31777	HSK100AH100ER25	100	1÷16	42	25	37	40	•
100	214-31725	HSK100AH100ER32	100	2÷20	50	32	38	48	•
100	214-31731	HSK100AH120ER40	120	3÷30	63	40	37	60	•
125	264-31747	HSK125AH100ER25	100	1÷16	42	25	37	42	•
125	264-31748	HSK125AH100ER32	100	2÷20	50	32	38	48	•
125	264-31749	HSK125AH120ER40	120	3÷30	63	40	37	60	•

STANDARD

Accessories
 Accessori
 Zubehör
 Accessoires
 Принадлежности
 零件



07

COLLET CHUCK KITS KIT PORTAPINZE HSK
 HSK-SPANNFUTTERSATZ JEUX PORTE-PINCES HSK
 НАБОРЫ ЦАНГОВЫХ ПАТРОНОВ И ЦАНГ 弹簧夹头组件

DIN 69893

Kit Box: 1 Collet chuck + 10 er collets + 1 wrench

Cassetta Corredo: 1 Portapinze + 10 pinze + chiave

Ausstattungskasten: 1 Spannfutter + 10 Spannzangen ER... + 1 Spannschlüssel

Boîte d'équipement: 1 porte-pince + 10 pinces ER... + 1 clé

Набор: 1 патрон + 10 цанг + 1 ключ

组件盒: 1个弹簧夹刀柄 + 10个夹头+扳手



HSK63	DESCRIZIONE DESCRIPTION
KITHSK63ER25	N° 1 portapinze + 10 pinze ER25 + chiave N° 1 collet chuck + 10 collets ER25 + wrench (ER25 Ø 2-3-4-5-6-8-10-12-14-16)
KITHSK63ER32	N° 1 portapinze + 10 pinze ER32 + chiave N° 1 collet chuck + 10 collets ER32 + wrench (ER32 Ø 3-4-6-8-10-12-14-16-18-20)
KITHSK63ER40	N° 1 portapinze + 10 pinze ER40 + chiave N° 1 collet chuck + 10 collets ER40 + wrench (ER40 Ø 5-6-8-10-12-16-20-22-24-26)

MILLING CHUCK MANDRINI FORTE SERRAGGIO
 KRAFTSPANNFUTTER MANDRINS A FORT SERRAGE
 УСИЛЕННЫЕ ОПРАВКИ 铣夹头

DIN 69893 A+C

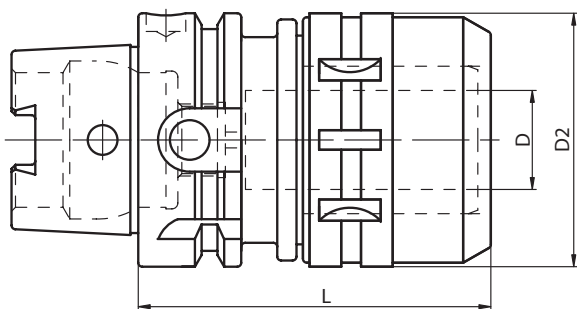

HSK	CODE N.	DESCRIPTION	D	D2	L	G6,3 12000
63	214-01701	HSK63AH90C20	20	54	90	•
63	214-01702	HSK63AH110C32	32	72	110	•
100	214-01705	HSK100AH110C20	20	54	110	•
100	214-01706	HSK100AH123C32	32	72	123	•
125	214-01708	HSK125AH125C32	32	72	125	•

- SUPPLIED WITH WRENCH • FORNITI CON CHIAVE INCLUSA
- INKLUSIVE SPANNSCHLÜSSEL • CLÉ INCLUSE
- ПОСТАВЛЯЕТСЯ С КЛЮЧОМ • 供货时提供扳手

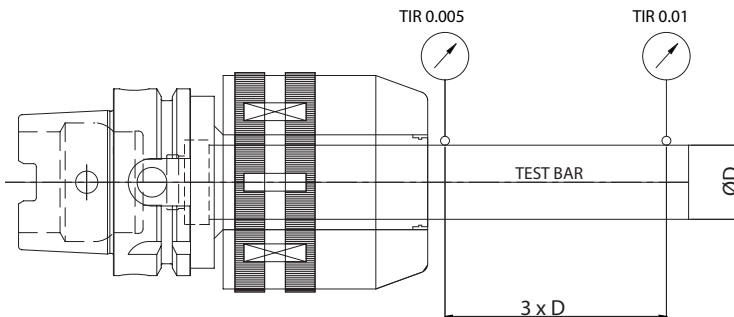

pag. 170



pag. 170

Accessories
 Accessori
 Zubehör
 Accessoires
 Принадлежности
 零件

MILLING CHUCK (diameter)	SPECIFICATION (DIN)	RUN-OUT (3xD)	CLAMPING TORQUE
C20	DIN 69893 A	0~0,01	980M.m (100 Kgf.m)
C32	HSK40A		3430M.m (350 Kgf.m)
	HSK50A		
	HSK63A HSK100A		

MILLING CHUCK KITS KIT FORTE SERRAGGIO
 KRAFTSPANNFUTTERSATZ JEUX À FORT SERRAGE
 НАБОРЫ СИЛОВЫХ ПАТРОНОВ С ЦАНГАМИ К НИМ 铣夹头组件

DIN 69893

Kit Box: 1 milling chuck + 1 collets kit + 1 wrench

Cassetta Corredo: 1 mandrino forte serraggio + 1 serie pinze + 1 chiave

Ausstattungskasten: 1 Kraftspannfutter + 1 Spannzangensatz + 1 Spannschlüssel

Boîte d'équipement: 1 mandrin à fort serrage + 1 jeux de pince + 1 clé

Набор: 1 патрон + 1 набор цанг + 1 ключ

组件盒: 1 个铣夹头 + 1 个夹头套装 + 1 个扳手



CODICE ORDINAZIONE ORDER CODE	COMPOSIZIONE COMPOSITION
KIT HSK63A C20	N° HSK63AH107C20 + n°5 pinze K20: Ø6,8,10,12,16 + chiave N° HSK63AH107C20 + 5 collets K20: Ø6,8,10,12,16 + wrench
KIT HSK63A C32	N° HSK63AH120C32 + n°7 pinze K32: Ø6,8,10,12,16,20,25 + chiave N° HSK63AH120C32 + 7 collets K32: Ø6,8,10,12,16,20,25 + wrench

MILLING CUTTER ARBORs FOR SCREW-ON TYPE MILLING CUTTERS MANDRINI PER FRESE CON ATTACCO FILETTATO
 SPANFUTTER FÜR EINSCHRAUBFRÄSER MANDRINS POUR FRAISES A VISSER
 ОПРАВКИ ДЛЯ ФРЕЗЕРНЫХ ГОЛОВОК 螺纹连接铣刀的铣刀杆

DIN 69893 A+C

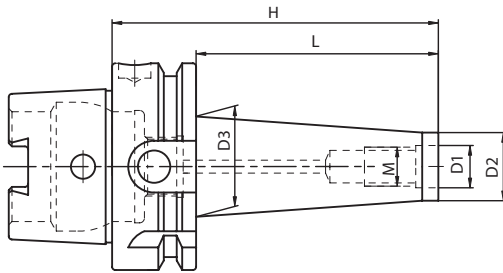

HSK	CODE N.	DESCRIPTION	M	D1	D2	D3	H	L	G2,5 25000
63	217-81779	HSK63AH76M8	M8	8.5	13	23	76	50	•
63	217-81790	HSK63AH76M10	M10	10.5	18	23	76	50	•
63	217-81782	HSK63AH101M10	M10	10.5	18	28	101	75	•
63	217-81783	HSK63AH126M10	M10	10.5	18	28	126	100	•
63	217-81784	HSK63AH76M12	M12	12.5	21	24	76	50	•
63	217-81785	HSK63AH101M12	M12	12.5	21	31	101	75	•
63	217-81786	HSK63AH126M12	M12	12.5	21	31	126	100	•
63	217-81787	HSK63AH76M16	M16	17	29	34	76	50	•
63	217-81788	HSK63AH101M16	M16	17	29	34	101	75	•
63	217-81789	HSK63AH126M16	M16	17	29	36	126	100	•

HIGH BALANCED

EXTENSION FOR SCREW IN TYPE MILLS PROLUNGHE PER FRESE CON ATTACCO FILETTATO
 VERLÄNGERUNG FÜR EINSCHRAUBFRÄSER RALLONGES POUR FRAISES À VISSER
 КОРПУСА ДЛЯ ФРЕЗЕРНЫХ ГОЛОВОК 螺纹型铣刀加长杆

DIN 69893 A+C

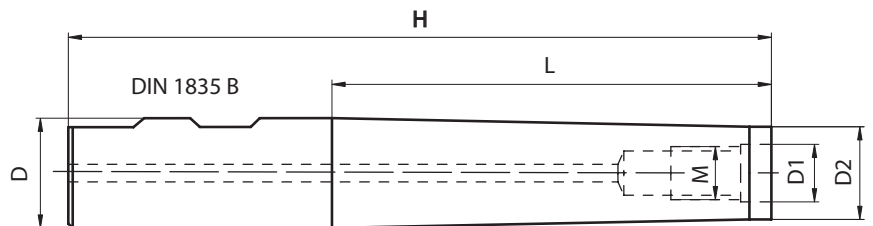

CODE N.	DESCRIPTION	D	M	D1	D2	H	L
217-85201	D16H115M8	16	M8	8.5	12.8	115	60
217-85202	D16H160M8	16	M8	8.5	12.8	160	100
217-85203	D20H120M10	20	M10	10.5	17.8	120	60
217-85204	D20H160M10	20	M10	10.5	17.8	160	100
217-85205	D25H160M12	25	M12	12.5	20.8	160	100
217-85206	D32H160M16	32	M16	17	28.8	160	100

EXTENSION FOR SCREW IN END MILLS PROLUNGHE PER FRESE FILETTATE
 VERLÄNGERUNG FÜR EINSCHRAUBFRÄSER RALLONGES POUR FRAISES FILETEES
 УДЛИНИТЕЛИ ДЛЯ ФРЕЗЕРНЫХ ГОЛОВОК 螺纹型端铣刀加长杆

DIN 69893 A+C

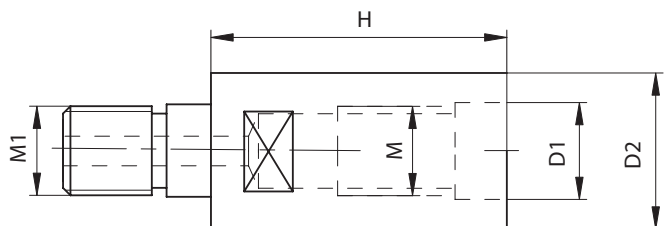

CODE N.	DESCRIPTION	M	M1	D1	D2	H
217-85709	M8H30M8	M8	M8	8.5	12.8	30
217-85710	M10H35M10	M10	M10	10.5	17.8	35
217-85711	M12H40M12	M12	M12	12.5	20.8	40
217-85712	M16H40M16	M16	M16	17	28.8	40

END MILL HOLDERS WELDON
ZYLINDERSCHAFTAUFNAHME WELDON
ОПРАВКИ С КРЕПЛЕНИЕМ WELDON

MANDRINI PORTAFRESE TIPO WELDON
MANDRINS POUR OUTILS TYPE WELDON
威尔登端铣夹具

DIN 69893 A+C - DIN 1835/B

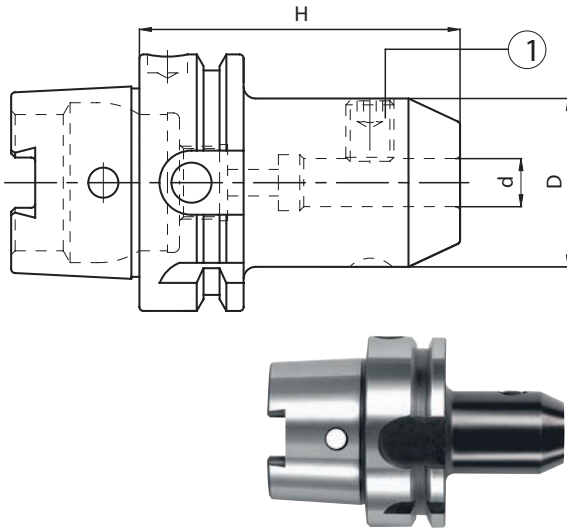

CODE N.	DESCRIPTION	H	d	D	G2,5 25000 RPM
213-91701	HSK63AH65WE06	65	6	25	•
213-91702	HSK63AH65WE08	65	8	28	•
213-91703	HSK63AH65WE10	65	10	35	•
213-91704	HSK63AH80WE12	80	12	42	•
213-91705	HSK63AH80WE14	80	14	44	•
213-91706	HSK63AH80WE16	80	16	48	•
213-91707	HSK63AH80WE18	80	18	50	•
213-91708	HSK63AH80WE20	80	20	52	•
213-91709	HSK63AH110WE25	110	25	65	•
213-91710	HSK63AH110WE32	110	32	72	•

Spare parts • Componenti • Ersatzteile
Pièces détachées • Запасные части • 零件

d	LOCKING SCREW	QUANTITY
6	811-106001	1
8	811-106002	1
10	811-106004	1
12;14	811-106005	1
16;18	811-106006	1
20	811-106007	1
25	811-106008	2
32	811-106009	2

HIGH BALANCED

07

END MILL HOLDERS WELDON LONG
ZYLINDERSCHAFTAUFNAHME WELDON LANG
ОПРАВКИ С КРЕПЛЕНИЕМ WELDON. УДЛИНЕННОЕ ИСПОЛНЕНИЕ.

MANDRINI PORTAFRESE TIPO WELDON, PROLUNGATI
MANDRINS POUR OUTILS TYPE WELDON, SERIE LONGUE
加长威尔登端铣夹具

DIN 69893 A+C

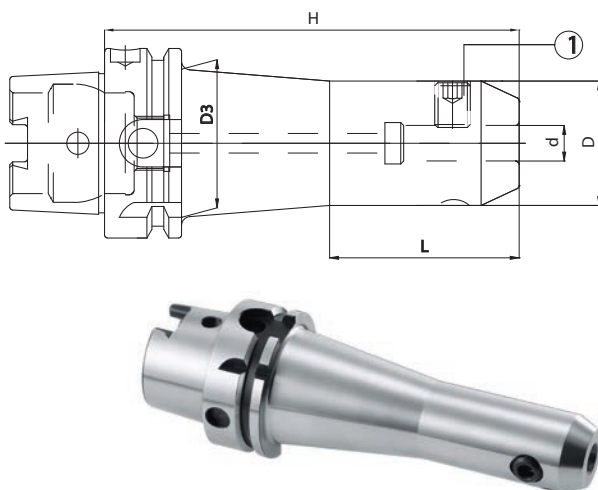

CODE N.	DESCRIPTION	H	d	D	D3	L	G2,5 25000 RPM
213-91722	HSK63AH100WE06	100	6	18	26	50	•
213-91723	HSK63AH100WE08	100	8	22	30	50	•
213-91724	HSK63AH100WE10	100	10	30	-	-	•
213-91725	HSK63AH100WE12	100	12	34	-	-	•
213-91727	HSK63AH100WE16	100	16	42	-	-	•
213-91729	HSK63AH100WE20	100	20	45	-	-	•

Spare parts • Componenti • Ersatzteile
Pièces détachées • Запасные части • 零件

d	LOCKING SCREW	QUANTITY
6	811-106015	1
8	811-106036	1
10	811-106003	1
12;14	811-106013	1
16;18	811-106027	1
20	811-106032	1
25	811-106014	2

HIGH BALANCED

END MILL HOLDERS WELDON MANDRINI PORTAFRESE TIPO WELDON
 ZYLINDERSCHAFTAUFNHME WELDON MANDRINS POUR OUTILS TYPE WELDON
 ОПРАВКИ С КРЕПЛЕНИЕМ WELDON 威尔登端铣夹具

DIN 69893 A+C - DIN 1835/B

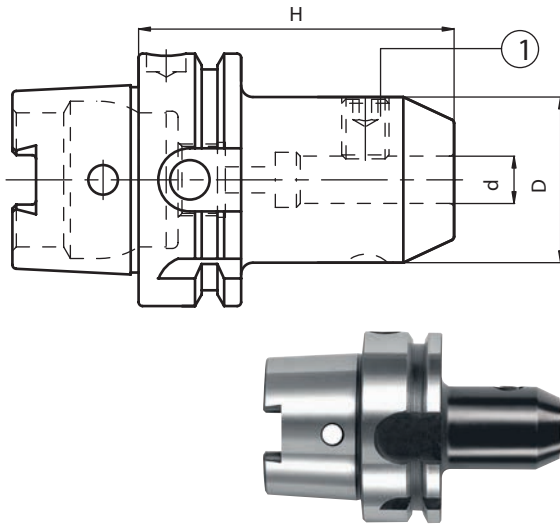

Spare parts • Componenti • Ersatzteile
 Pièces détachées • Запасные части • 零件

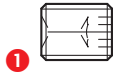
d	LOCKING SCREW	QUANTITY
		
6	811-106001	1
8	811-106002	1
10	811-106004	1
12;14	811-106005	1
16;18	811-106006	1
20	811-106007	1
25	811-106008	2
32;40	811-106009	2
50	811-106011	2

HSK	CODE N.	DESCRIPTION	H	d	D	G6,3 15000 RPM
40	213-11701	HSK40AH60WE06	60	6	25	•
40	213-11702	HSK40AH60WE08	60	8	28	•
40	213-11703	HSK40AH65WE10	65	10	35	•
40	213-11704	HSK40AH70WE12	70	12	42	•
40	213-11706	HSK40AH80WE16	80	16	48	•
40	213-11736	HSK40AH80WE20	80	20	52	•
50	213-11712	HSK50AH80WE16	80	16	48	•
50	213-11714	HSK50AH80WE20	80	20	52	•
50	213-11737	HSK50AH105WE25	105	25	65	•
63	213-11715	HSK63AH65WE06	65	6	25	•
63	213-11716	HSK63AH65WE08	65	8	28	•
63	213-11717	HSK63AH65WE10	65	10	35	•
63	213-11718	HSK63AH80WE12	80	12	42	•
63	213-11719	HSK63AH80WE14	80	14	44	•
63	213-11720	HSK63AH80WE16	80	16	48	•
63	213-11721	HSK63AH80WE18	80	18	50	•
63	213-11722	HSK63AH80WE20	80	20	52	•
63	213-11723	HSK63AH110WE25	110	25	65	•
63	213-11724	HSK63AH110WE32	110	32	72	•
63	263-11780	HSK63AH120WE40	120	40	80	•
100	213-11738	HSK100AH90WE06	90	6	25	•
100	213-11739	HSK100AH90WE08	90	8	28	•
100	213-11740	HSK100AH90WE10	90	10	35	•
100	213-11741	HSK100AH100WE12	100	12	42	•
100	213-11742	HSK100AH100WE14	100	14	44	•
100	213-11743	HSK100AH100WE16	100	16	48	•
100	213-11744	HSK100AH100WE18	100	18	50	•
100	213-11745	HSK100AH110WE20	110	20	52	•
100	213-11746	HSK100AH120WE25	120	25	65	•
100	213-11747	HSK100AH120WE32	120	32	72	•
100	213-11748	HSK100AH120WE40	120	40	80	•
100	263-11733	HSK100AH130WE50	130	50	100	•

07



HEAD OFFICE - KINTEK S.R.L. - MAPPANO - TORINO - ITALY

END MILL HOLDERS WELDON LONG MANDRINI PORTAFRESE TIPO WELDON, PROLUNGATI
 ZYLINDERSCHAFTAUFNAHME WELDON LANG MANDRINS POUR OUTILS TYPE WELDON, SERIE LONGUE
 ОПРАВКИ С КРЕПЛЕНИЕМ WELDON. УДЛИНЕННОЕ ИСПОЛНЕНИЕ. 加长威尔登端铣夹具

DIN 69893 A+C - DIN 6388

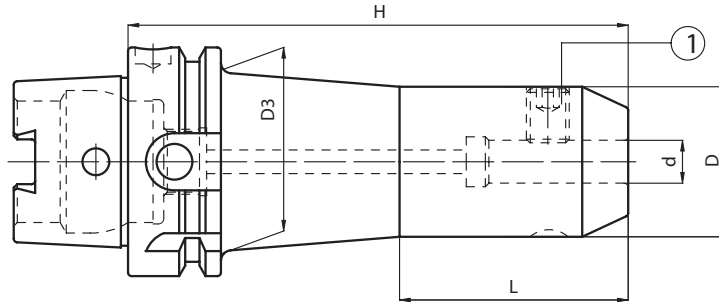

HSK	CODE N.	DESCRIPTION	H	d	D	L	D3	G6,3 15000 RPM
63	263-11757	HSK63AH100WE06	100	6	18	50	26	•
63	263-11758	HSK63AH100WE08	100	8	22	50	30	•
63	263-11759	HSK63AH100WE10	100	10	30	-	-	•
63	263-11760	HSK63AH100WE12	100	12	34	-	-	•
63	263-11762	HSK63AH100WE16	100	16	42	-	-	•
63	263-11764	HSK63AH100WE20	100	20	45	-	-	•
63	263-11765	HSK63AH160WE06	160	6	18	50	34	•
63	263-11766	HSK63AH160WE08	160	8	22	50	38	•
63	263-11767	HSK63AH160WE10	160	10	30	65	46	•
63	263-11768	HSK63AH160WE12	160	12	34	70	50	•
63	263-11770	HSK63AH160WE16	160	16	42	70	50	•
63	263-11772	HSK63AH160WE20	160	20	45	70	53	•
100	213-11781	HSK100AH160WE06	160	6	18	50	46	•
100	213-11782	HSK100AH160WE08	160	8	22	50	50	•
100	213-11783	HSK100AH160WE10	160	10	30	65	48	•
100	213-11784	HSK100AH160WE12	160	12	34	70	51	•
100	263-11773	HSK100AH160WE14	160	14	36	70	50	•
100	213-11785	HSK100AH160WE16	160	16	42	70	59	•
100	263-11774	HSK100AH160WE18	160	18	44	70	58	•
100	213-11786	HSK100AH160WE20	160	20	45	70	55	•
100	263-11775	HSK100AH160WE25	160	25	55	80	66	•

Spare parts • Componenti • Ersatzteile
 Pièces détachées • Запасные части • 零件

d	LOCKING SCREW	QUANTITY
6	811-106015	1
8	811-106036	1
10	811-106003	1
12;14	811-106013	1
16;18	811-106027	1
20	811-106032	1
HSK63/25	811-106014	2
HSK100/25	811-106042	2

NEW PRODUCTION PLANT - A.M.T. S.R.L. - CASELLE T.SE - TORINO - ITALY



INDEXABLE DRILL HOLDERS PORTAPUNTE
 VOLLBOHRERHALTER PORTE-OUTIL POUR BARRES DE PERCAGE
 СВЕРЛИЛЬНЫЕ ПАТРОНЫ 钻刀柄

DIN 69893 A+C

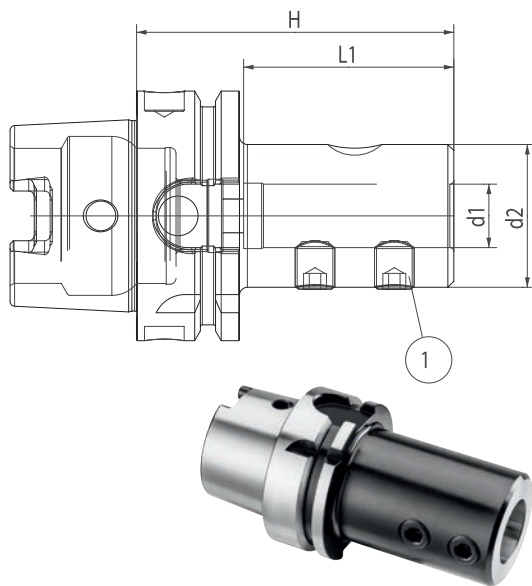

CODE N.	DESCRIPTION	HSK	d1	d2	H	L1
267-91772	HSK63AH80D16-E1	63	16	36	80	54
267-91773	HSK63AH80D20-E1	63	20	40	80	54
267-91774	HSK63AH90D25-E1	63	25	45	90	59
267-91775	HSK63AH90D32-E1	63	32	52	90	63

Spare parts • Componenti • Ersatzteile
 Pièces détachées • Запасные части • 零件

d	LOCKING SCREW	QUANTITY
16, 20	811-402003	2
25, 32	811-402005	2

END MILL HOLDERS WELDON WITH COOLANT CHANNELS PORTAFRESE TIPO WELDON CON LUBRIFICAZIONE
 STEILKEGELAUFNAHMEN WELDON MIT KÜHLKANÄLE PORTE-FRAISES TYPE WELDON AVEC CANAL D'ARROSAGE
 ОПРАВКИ С КРЕПЛЕНИЕМ WELDON С ВНУТРЕННЕЙ ПОДАЧЕЙ СОЖ 威尔登式端铣夹具，配备出水结构

DIN 69893 A+C - DIN 1835 B

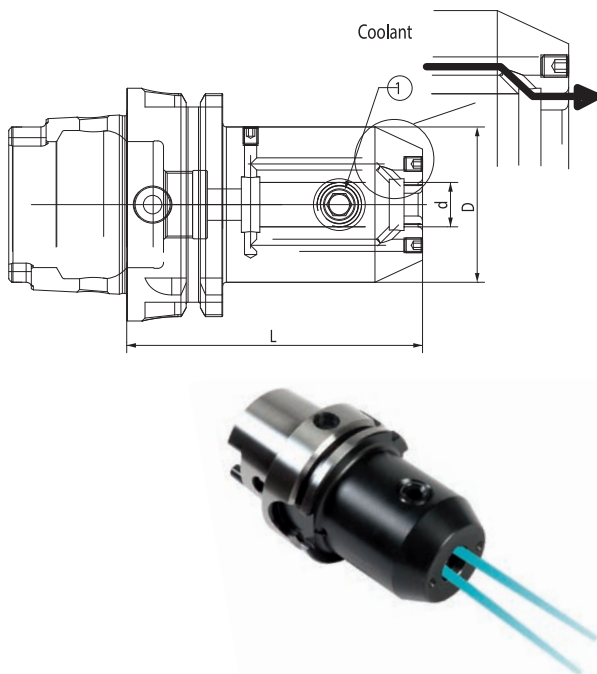

CODE N.	DESCRIPTION	HSK	d	H	D	G6,3 15000
213-61764	HSK63AH65WE06-IK	63	6	65	25	•
213-61765	HSK63AH65WE08-IK	63	8	65	28	•
213-61766	HSK63AH65WE10-IK	63	10	65	35	•
213-61767	HSK63AH80WE12-IK	63	12	80	42	•
213-61768	HSK63AH80WE14-IK	63	14	80	44	•
213-61769	HSK63AH80WE16-IK	63	16	80	48	•
213-61770	HSK63AH80WE18-IK	63	18	80	50	•
213-61771	HSK63AH80WE20-IK	63	20	80	52	•
213-61772	HSK63AH110WE25-IK	63	25	110	65	•
213-61773	HSK63AH110WE32-IK	63	32	110	72	•
213-61774	HSK63AH125WE40-IK	63	40	125	80	•

Spare parts • Componenti • Ersatzteile
 Pièces détachées • Запасные части • 零件

d	LOCKING SCREW	QUANTITY
6	811-106001	1
8	811-106002	1
10	811-106004	1
12,14	811-106005	1
16,18	811-106006	1
20	811-106007	1
25	811-106008	2
32	811-106009	2
40	811-106009	2

FACE MILL HOLDERS-TENONS DRIVE
AUFSTECKFRÄSDORNE FÜR FRÄSER MIT QUERNUT
ОПРАВКИ ДЛЯ НАСАДНЫХ ФРЕЗ

MANDRINI PORTAFRESE A TRASCINAMENTO FISSO
MANDRINS PORTE-FRAISE-ENTRAÎNEMENT PAR TENONS
平面铣刀柄 - 凸榫驱动

DIN 69893 A+C - ISO 3937

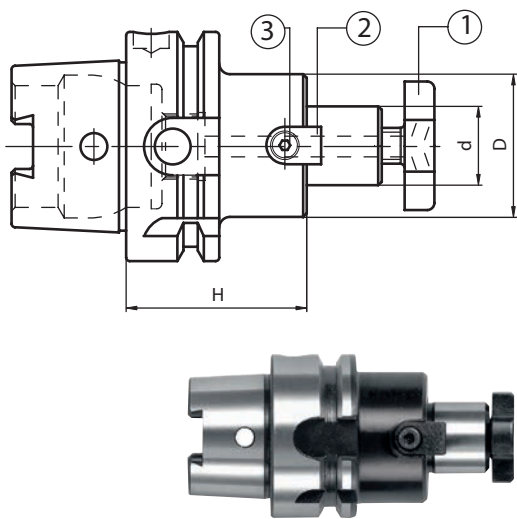

HSK	CODE N.	DESCRIPTION	H	d	D	G6,3 15000 RPM
32	216-71748	HSK32AH45D16F	45	16	38	•
32	216-71749	HSK32AH50D22F	50	22	48	•
40	216-71701	HSK40AH45D16F	45	16	38	•
40	216-71702	HSK40AH50D22F	50	22	48	•
40	216-71703	HSK40AH55D27F	55	27	58	•
50	216-71705	HSK50AH55D22F	55	22	48	•
63	216-71708	HSK63AH45D16F	45	16	38	•
63	216-71709	HSK63AH50D22F	50	22	48	•
63	216-71710	HSK63AH55D27F	55	27	58	•
63	216-71711	HSK63AH60D32F	60	32	78	•
63	216-71750	HSK63AH65D40F	65	40	88	•
100	216-71712	HSK100AH55D16F	55	16	38	•
100	216-71713	HSK100AH55D22F	55	22	48	•
100	216-71714	HSK100AH55D27F	55	27	58	•
100	216-71715	HSK100AH60D32F	60	32	78	•
100	216-71716	HSK100AH65D40F	65	40	88	•
125	266-71789	HSK125AH50D22F	50	22	48	•
125	266-71790	HSK125AH55D27F	55	27	58	•
125	266-71791	HSK125AH60D32F	60	32	78	•
125	266-71792	HSK125AH65D40F	65	40	88	•

STANDARD

Spare parts • Componenti • Ersatzteile • Pièces détachées • Запасные части • 零件

d	CROSS SCREW	CROSS SCREW ON ENQUIRY	DOG	SCREW	WRENCH
16	811-107003	811-107013	814-202280	811-101004	816-13002
22	811-107004	811-107014	814-202250	811-101011	816-13003
27	811-107005	811-107015	814-202270	811-101018	816-13004
32	811-107006	811-107016	814-202630	811-101029	816-13005
40	811-107007	811-107017	814-202710	811-101029	816-13006

Accessories
Accessori
Zubehör
Accessoires
Принадлежности
零件



FACE MILL HOLDERS-TENONS DRIVE MANDRINI PORTAFRESE A TRASCINAMENTO FISSO
 AUFSTECKFRÄSDORNE FÜR FRÄSER MIT QUERNUT MANDRINS PORTE-FRAISE-ENTRAÎNEMENT PAR TENONS
 ОПРАВКИ ДЛЯ НАСАДНЫХ ФРЕЗ. УДЛИНЕННОЕ ИСПОЛНЕНИЕ. 平面铣刀柄 - 凸榫驱动

DIN 69893 A+C - ISO 3937

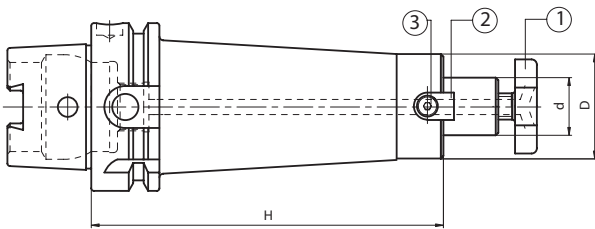

Accessories
 Accessori
 Zubehör
 Accessoires
 Принадлежности
 零件



HSK	CODE N.	DESCRIPTION	H	d	D	D3	G6,3 15000
63	216-71791	HSK63AH100D16F	100	16	38	40	•
63	216-71792	HSK63AH100D22F	100	22	48	-	•
63	216-71793	HSK63AH100D27F	100	27	58	-	•
63	216-71794	HSK63AH100D32F	100	32	78	-	•
63	216-71795	HSK63AH100D40F	100	40	88	-	•
63	216-71717	HSK63AH160D16F	160	16	32	38	•
63	216-71718	HSK63AH160D22F	160	22	40	48	•
63	216-71719	HSK63AH160D27F	160	27	48	50	•
63	216-71720	HSK63AH160D32F	160	32	58	-	•
100	216-71796	HSK100AH100D16F	100	16	38	40	•
100	216-71797	HSK100AH100D22F	100	22	48	50	•
100	216-71798	HSK100AH100D27F	100	27	58	60	•
100	216-71799	HSK100AH100D32F	100	32	78	80	•
100	266-71701	HSK100AH100D40F	100	40	88	-	•
100	216-71722	HSK100AH160D16F	160	16	32	42	•
100	216-71723	HSK100AH160D22F	160	22	40	50	•
100	216-71724	HSK100AH160D27F	160	27	48	68	•
100	216-71725	HSK100AH160D32F	160	32	58	76	•
100	216-71726	HSK100AH160D40F	160	40	70	84	•
125	266-71793	HSK125AH100D22F	100	22	48	50	•
125	266-71794	HSK125AH100D27F	100	27	58	63	•
125	266-71795	HSK125AH100D32F	100	32	78	80	•
125	266-71796	HSK125AH100D40F	100	40	88	-	•
125	266-71797	HSK125AH160D22F	160	22	40	50	•
125	266-71798	HSK125AH160D27F	160	27	48	63	•
125	266-71799	HSK125AH160D32F	160	32	58	80	•
125	216-91701	HSK125AH160D40F	160	40	70	88	•

Spare parts • Componenti • Ersatzteile • Pièces détachées • Запасные части • 零件

d	CROSS SCREW	CROSS SCREW ON ENQUIRY	DOG H100	SCREW H100	DOG H160	SCREW H160	WRENCH
16	811-107003	811-107013	814-202280	811-101004	814-202140	811-101003	816-13002
22	811-107004	811-107014	814-202250	811-101011	814-202150	811-101010	816-13003
27	811-107005	811-107015	814-202270	811-101018	814-202160	811-101017	816-13004
32	811-107006	811-107016	814-202630	811-101029	814-202170	811-101027	816-13005
40	811-107007	811-107017	814-202710	811-101029	814-202180	811-101028	816-13006



COMBI-SHELL MILL ADAPTORS MANDRINI PORTAFRESE COMBINATI
 KOMBI - AUFSTECKFRÄSDORNE MANDRINS PORTE- FRAISES A DOUBLE USAGE
 КОМБИНИРОВАННЫЕ ОПРАВКИ ДЛЯ НАСАДНЫХ ФРЕЗ 复合式平面铣刀接头

DIN 69893 A+C - DIN 6538



HSK	CODE N.	DESCRIPTION	D	L1	L2	L3	D2	G6,3 8000 RPM
63	216-11708	HSK63AH60D16C	16	60	17	27	32	•
63	216-11709	HSK63AH60D22C	22	60	19	31	40	•
63	216-11710	HSK63AH60D27C	27	60	21	33	48	•
63	216-11711	HSK63AH65D32C	32	65	24	38	58	•
63	216-11712	HSK63AH70D40C	40	70	27	41	70	•

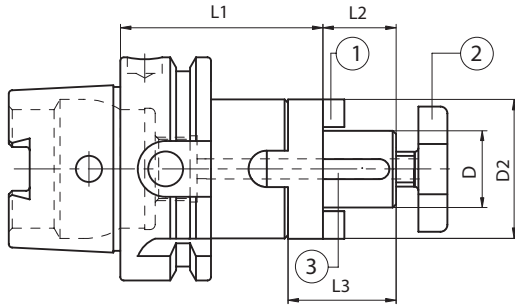

Spare parts • Componenti • Ersatzteile • Pièces détachées
 Запасные части • 零件

D	RING	CROSS SCREW	KEY	WRENCH
16	814-30001	811-107003	814-201010	816-130002
22	814-30002	811-107004	814-201020	816-130003
27	814-30003	811-107005	814-201030	816-130004
32	814-30004	811-107006	814-201040	816-130005
40	814-30005	811-107007	814-201050	816-130006

07

COMBI-SHELL MILL ADAPTORS LONG MANDRINI PORTAFRESE COMBINATI, SERIE LUNGA
 KOMBI - AUFSTECKFRÄSDORNE LANG MANDRINS PORTE- FRAISES A DOUBLE USAGE, SERIE LONGUE
 КОМБИНИРОВАННЫЕ ОПРАВКИ ДЛЯ НАСАДНЫХ ФРЕЗ 加长复合式平面铣接头

DIN 69893 A+C - DIN 6538



HSK	CODE N.	DESCRIPTION	D	L1	L2	L3	D2	D3	G6,3 8000 RPM
63	216-11777	HSK63AH100D16C	16	100	17	27	32	40	•
63	216-11728	HSK63AH100D22C	22	100	19	31	40	-	•
63	216-11736	HSK63AH100D27C	27	100	21	33	48	-	•
63	216-11778	HSK63AH100D32C	32	100	24	38	58	-	•
63	216-11779	HSK63AH100D40C	40	100	27	41	70	-	•
63	216-11770	HSK63AH160D22C	22	160	19	31	40	50	•

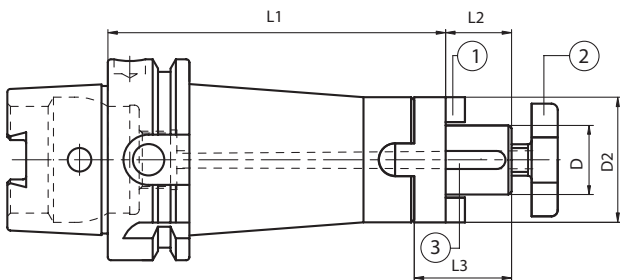

Spare parts • Componenti • Ersatzteile • Pièces détachées
 Запасные части • 零件

D	RING	CROSS SCREW	KEY	WRENCH
16	814-30001	811-107003	814-201010	816-130002
22	814-30002	811-107004	814-201020	816-130003
27	814-30003	811-107005	814-201030	816-130004
32	814-30004	811-107006	814-201040	816-130005
40	814-30005	811-107007	814-201050	816-130006

FACE MILL HOLDERS-TENONS DRIVE-WITH
INTERNAL COOLANT SUPPLY
AUFSTECKFRÄSDORNE FÜR FRÄSER MIT QUERNUT
UND KÜHLMITTELZUFUHR

MANDRINI PORTAFRESE A TRASCINAMENTO FISSO
CON PASSAGGIO REFRIGERANTE
MANDRINS PORTE-FRAISE-ENTRAÎNEMENT PAR TENONS
AVEC ARROSSAGE INTERNE

ОПРАВКИ ДЛЯ НАСАДНЫХ ФРЕЗ С ВНУТРЕННЕЙ ПОДАЧЕЙ СОЖ

平面铣刀柄 - 凸榫驱动带有更大的法兰直径

DIN 69893 A+C - ISO 3937

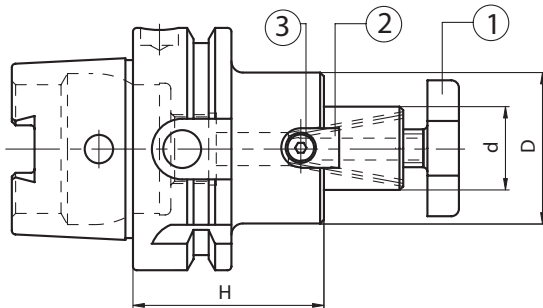

Accessories
Accessori
Zubehör
Accessoires
Принадлежности
零件



HSK	CODE N.	DESCRIPTION	H	d	D	G6,3 15000
40	216-71733	HSK40AH50D22F-L	50	22	48	•
63	216-71739	HSK63AH45D16F-L	45	16	38	•
63	216-71740	HSK63AH50D22F-L	50	22	48	•
63	216-71741	HSK63AH55D27F-L	55	27	58	•
63	216-71742	HSK63AH60D32F-L	60	32	78	•

Spare parts • Componenti • Ersatzteile • Pièces détachées
Запасные части • 零件

d	CROSS SCREW	DOG	SCREW	WRENCH
16	811-107003	814-202280	811-101004	816-130002
22	811-107004	814-20225 0	811-101011	816-130003
27	811-107005	814-202270	811-101018	816-130004
32	811-107006	814-202630	811-101029	816-130005
40	811-107007	814-202710	811-101029	816-130006



NC-DRILL CHUCKS FOR LEFT AND RIGHT ROTATION
 NC-BOHRFUTTER FÜR RECHTS- UND LINKSLAUF
 СВЕРЛИЛЬНЫЕ ПАТРОНЫ С ВРАЩЕНИЕМ ПО- И ПРОТИВ
 ЧАСОВОЙ СТРЕЛКИ ДЛЯ СТАНКОВ С ЧПУ

MANDRINI PORTAPUNTE INTEGRALI PER ROTAZIONE
 DESTRA E SINISTRA
 MANDRINS DE PERCAGE CNC POUR ROTATION GAUCHE-DROITE
 左右旋转数控钻夹头

DIN 69893 A+C

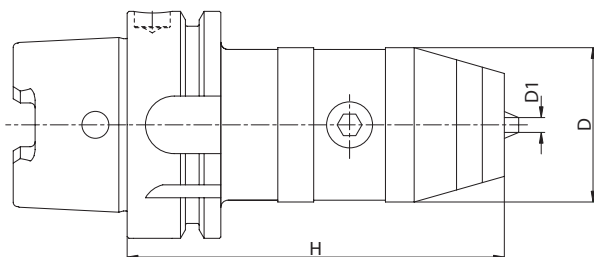

HSK	CODE N.	DESCRIPTION	H	D	CLAMPING CAPACITY
63	252-11751	HSK63AH130R0,5-13X	130	50	0,5-13
63	252-11752	HSK63AH140R2,5-16X	140	57	2,5-16
100	252-11753	HSK100AH111R0,5-13X	111	50	0,5-13
100	252-11754	HSK100AH116R2,5-16X	116	57	2,5-16

RUNOUT ACCURACY 0.05 MM T.I.R.

Suitable for right and left rotation up to 35000 rpm.

PRECISIONE DI ROTAZIONE 0.05 MM.

Adatti per rotazione sia destra che sinistra, con velocità max di 35000 g/min.

RUNDLAUFGENAUIGKEIT 0,05 MM.

Sowohl für Rechts- als auch für Linkslauf mit Höchstgeschwindigkeit 35000 U/min geeignet.

PRÉCISION DE ROTATION 0,05 MM.

Appropriés pour rotation à droite et à gauche avec vitesse max. de 35000 tour par minute.

БИЕНИЕ 0,05 MM

Можно вращать по- и против часовой стрелки со скоростью до 35000 об/мин.

径向跳动精度 0.05 MM T.I.R.

适用于最高为 35000 转/分钟的左右旋转

07

NC-DRILL CHUCKS FOR LEFT AND RIGHT ROTATION
 NC-BOHRFUTTER FÜR RECHTS- UND LINKSLAUF
 СВЕРЛИЛЬНЫЕ ПАТРОНЫ С ВРАЩЕНИЕМ ПО- И ПРОТИВ
 ЧАСОВОЙ СТРЕЛКИ ДЛЯ СТАНКОВ С ЧПУ

MANDRINI PORTAPUNTE INTEGRALI PER ROTAZIONE
 DESTRA E SINISTRA
 MANDRINS DE PERCAGE CNC POUR ROTATION GAUCHE-DROITE
 左右旋转数控钻夹头

DIN 69893 A+C

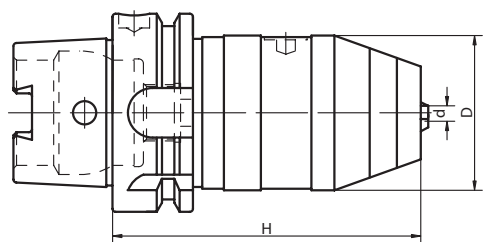

HSK	CODE N.	DESCRIPTION	H	D	CLAMPING CAPACITY	WRENCH
63 *	252-11733	HSK63AH105R1-13X	105	50	1-13	816-152001
63 *	252-11734	HSK63AH110R3-16X	110	57	3-16	816-152002

* WITH INTERNAL COOLANT • CON PASSAGGIO REFRIGERANTE INTERNO
 MIT INNENKÜHLUNG • AVEC ARROSAGE INTERNE
 С ВНУТРЕННЕЙ ПОДАЧЕЙ СОЖ • 配备内部冷却剂

RUNOUT ACCURACY 0.05 MM T.I.R.

Suitable for right and left rotation up to 8000 rpm.

PRECISIONE DI ROTAZIONE 0.05 MM.

Adatti per rotazione sia destra che sinistra, con velocità max di 8000 g/min.

RUNDLAUFGENAUIGKEIT 0.05 MM

Sowohl für rechts - als auch links laufende Bearbeitungen geeignet, mit Höchstgeschwindigkeit von 8000 u/min.

PRÉCISION DE ROTATION 0,05 MM.

Appropriés pour rotation à droite et à gauche avec vitesse max. de 8000 tour par minute.

БИЕНИЕ 0,05 MM

Можно вращать по- и против часовой стрелки со скоростью до 8000 об/мин.

径向跳动精度 0.05 MM T.I.R.

适用于最高为 8000 转/分钟的左右旋转

MORSE TAPER ADAPTORS FOR DRILLS
 ZWISCHENHÜLSEN FÜR MORSEKEGEL MIT AUSTREIBBLAPPEN
 ОПРАВКИ ДЛЯ КОНУСА МОРЗЕ С ЛАПКОЙ
 MANDRINI PORTAPUNTE ATTACCO CONO MORSE
 DOUILLES POUR CONE MORSE A TENON
 莫氏锥度钻接头

DIN 69893 A+C - DIN 228-2 FORM D

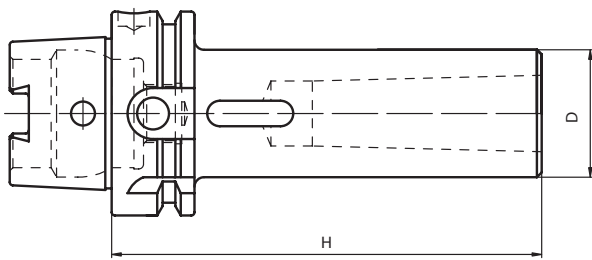

HSK	CODE N.	DESCRIPTION	MORSE	H	D	G6,3 8000 RPM
63	212-41706	HSK63AH100CM1P	1	100	25	•
63	212-41707	HSK63AH115CM2P	2	115	32	•
63	212-41708	HSK63AH135CM3P	3	135	40	•
63	212-41709	HSK63AH160CM4P	4	160	48	•
100	212-41716	HSK100AH120CM2P	2	120	32	•
100	212-41717	HSK100AH150CM3P	3	150	40	•
100	212-41718	HSK100AH170CM4P	4	170	48	•
100	212-41719	HSK100AH205CM5P	5	205	63	•

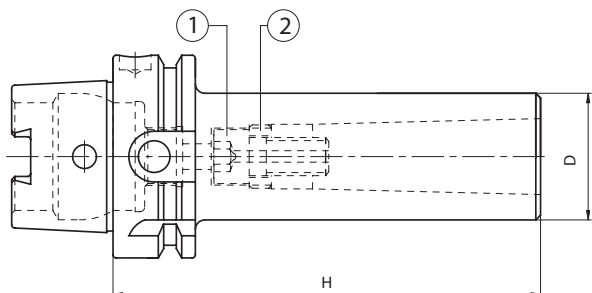

MORSE TAPER MILL ADAPTERS WITH INTERNAL COOLANT
 ZWISCHENHÜLSEN FÜR MORSEKEGEL MIT
 ZENTRALER KÜHLMITTELZUFUHR
 ОПРАВКИ ДЛЯ КОНУСА МОРЗЕ С ВНУТРЕННИМ ПОДВОДОМ СОЖ
 MANDRINI PORTAFRESE CON ATTACCO CONO MORSE
 CON REFRIGERAMENTO INTERNO
 DOUILLES POUR CONE MORSE AVEC ABROSAGE
 莫氏锥度铣刀接头配备内部冷却剂

DIN 69893 A+C - DIN 228-2 FORM C



HSK	CODE N.	DESCRIPTION	MORSE	H	D	G6,3 8000 RPM
63	212-21708	HSK63AH100CM1F	1	100	25	•
63	212-21709	HSK63AH115CM2F	2	115	32	•
63	212-21710	HSK63AH135CM3F	3	135	40	•
63	212-21711	HSK63AH160CM4F	4	160	48	•
100	212-21715	HSK100AH150CM3F	3	150	40	•
100	212-21716	HSK100AH170CM4F	4	170	48	•

Spare parts • Componenti • Ersatzteile
 Pièces détachées • Запасные части • 零件

HSK MORSE	SCREW	RING
		
	1	2
40/1	811-401100	811-302037
40/2	811-401079	811-302031
40/3	811-401089	811-302032
50/1	811-401100	811-302037
50/2	811-401066	811-302031
50/3	811-401067	811-302032
63/1	811-401100	811-302037
63/2	811-401099	811-302031
63/3	811-401078	811-302032
63/4	811-401091	811-302036
100/2	811-401099	811-302031
100/3	811-401098	811-302032
100/4	811-401092	811-302036
100/5	811-401136	811-302034

TOOL EXTENSIONS HSK A+C PROLUNGHE HSK A+C
 VERLÄNGERUNGEN HSK A+C RALLONGES D'OUTILS HSK A+C HSK
 УДЛИНИТЕЛИ HSK A+C 加长 HSK A+C 刀具

DIN 69893 A+C



HSK	CODE N.	DESCRIPTION	D	H	① RING (complete)	② LOCKING UNIT (complete)
63	212-91703	HSK63AH100HSK63	63	100	H63A-AN	H63A-UBL
100	212-91705	HSK100AH140HSK100	100	140	H100A-AN	H100A-UBL

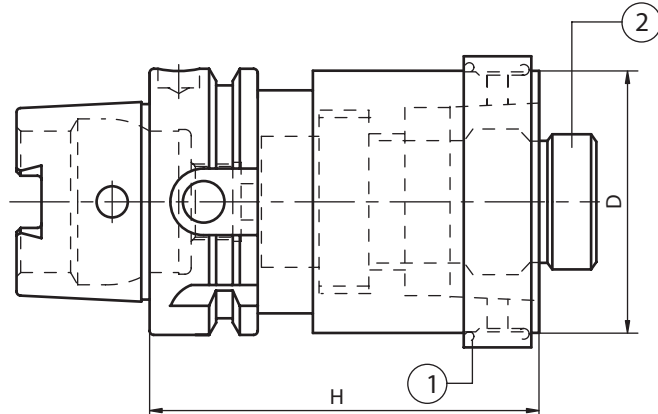

07

REDUCERS HSK A+C RIDUZIONI HSK A+C
 REDUZIERUNGEN HSK A+C PIÈCES DE REDUCTION HSK A+C
 ПЕРЕХОДНИКИ HSK A+C 变径 HSK A+C

DIN 69893 A+C



HSK	CODE N.	DESCRIPTION	D	H	① RING (complete)	② LOCKING UNIT (complete)
63	212-91710	HSK63H70HSK40	40	70	HN40-AN	H40A-UBL
63	212-91711	HSK63H80HSK50	50	80	HN50-AN	H50A-UBL
100	212-91713	HSK100AH100HSK63	63	100	H63A-AN	H63A-UBL
125	212-91719	HSK125AH145HSK100	100	145	H100A-AN	H100A-UBL

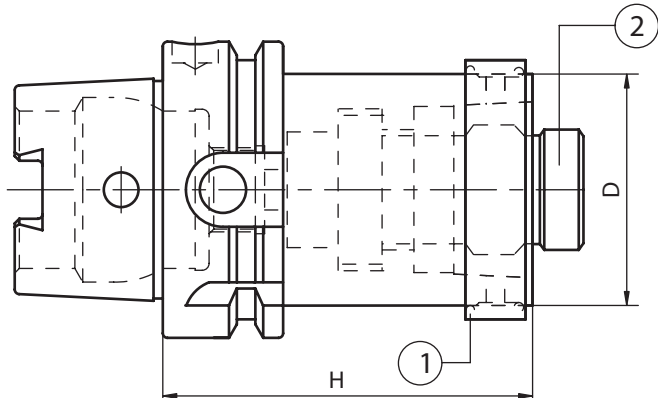

TENSION AND COMPRESSION TAPPING HEADS MASCHIATORI A DOPPIA COMPENSAZIONE
 GEWINDESCHNEID-SCHNELLWECHSELFUTTER MANDRINS DE TARAUDAGE A CHANGEMENT
 MIT LÄNGENAUSGLEICH RAPIDE A DOUBLE USAGE
 РЕЗЬБОНАРЕЗНЫЕ ПАТРОНЫ С КОМПЕНСАЦИЕЙ 张力和压缩丝攻头

DIN 69893 A+C



HSK	CODE N.	DESCRIPTION	SIZE	TOP RANGE	PRESS.	EXT.	d	D	H
63	M801063	HSK63AH72GR1	1	M3-M12	7.5	7.5	19	48	72
63	M802063	HSK63AH110GR2	2	M6-M20	10	10	31	60	110
100	M801100	HSK100AH80GR1	1	M3÷M12	7.5	7.5	19	48	80
100	M802100	HSK100AH100GR2	2	M6÷M20	10	10	31	60	100
100	M803100	HSK100AH144GR3	3	M14÷M33	17.5	17.5	48	79	144

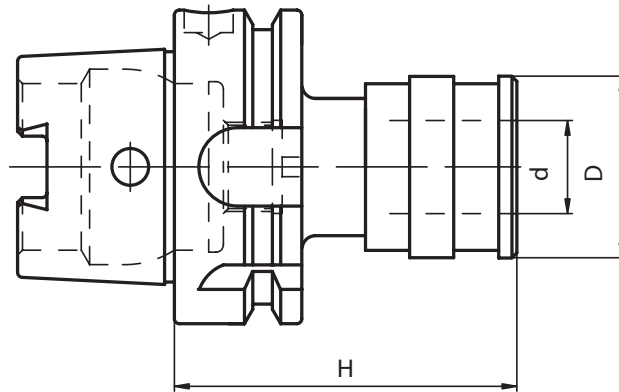

pag. 160



pag. 161

Accessories
 Accessori
 Zubehör
 Accessoires
 Принадлежности
 零件

BLANK TOOLHOLDERS WITH SOFT SHANK MANDRINI SEMILAVORATI A STELO TENERO
 ROHLINGE MIT WEICHEM SCHAFT BARRE D'ALEPAGE SEMI-FINIES
 ЗАГОТОВКИ ДЛЯ ОПРАВОК НЕЗАКАЛЕННЫЕ 帶軟柄的切斷工具柄

DIN 69893 A+C



HSK	CODE N.	DESCRIPTION	H	D
32	217-11712	HSK32AH150D35SM	150	35
40	217-11701	HSK40AH150D40SM	150	40
40	217-11702	HSK40AH200D52SM	200	52
50	217-11703	HSK50AH200D52SM	200	52
50	217-11704	HSK50AH200D63SM	200	63
63	217-11783	HSK63AH160D63SM	160	63
63	217-11705	HSK63AH250D63SM	250	63
63	217-11784	HSK63AH160D80SM	160	80
63	217-11706	HSK63AH250D80SM	250	80
100	217-11709	HSK100AH200D63SM	200	63
100	217-11710	HSK100AH250D80SM	250	80
100	217-11785	HSK100AH150D90SM	150	90
100	217-11711	HSK100AH300D90SM	300	90

HRC26-28

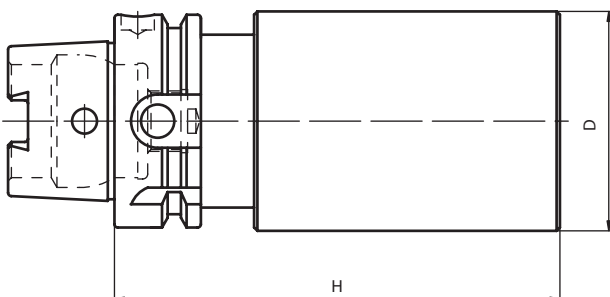



DIN 69893 E



TAPER SHANKS DATA SHEET DATI TECNICI CONI D'ATTACCO
 TECHNISCHE DATEN DER STEILKEGELWERKZEUGE DONNEES TECHNIQUES QUEUE D'OUTILS
 КОНСТРУКТИВНЫЕ РАЗМЕРЫ 锥柄数据表

DIN 69893 E

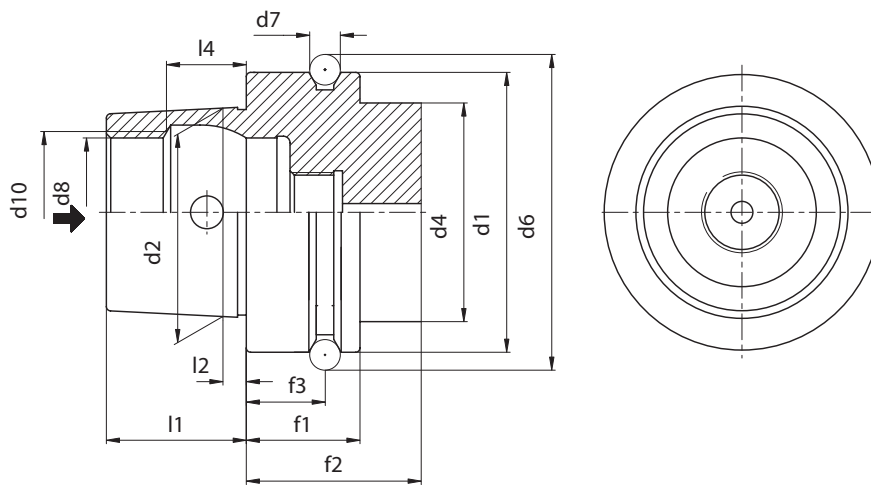

	HSK 25	HSK 32	HSK 40	HSK 50	HSK 63
d1	25	32	40	50	63
d2	19	24	30	38	48
d4	20	26	34	42	53
d6	28,5	37	45	59,3	72,3
d7	3	4	4	7	7
d8	14	17	21	26	34
d10	15	19	23	29	37
f1	10	20	20	26	26
f2	20	35	35	42	42
f3	4,5	16	16	18	18
l1	13	16	20	25	32
l2	2,5	3,2	4	5	6,3
l4	7,21	8,92	11,42	14,13	18,13

Form E

- Used for high frequency spindles and wood machining.
- Rotationally symmetrical, without key slots.
- Torque transmission via friction resistance.
- Central coolant supply possible through coolant tube.

Forma E

- Usato su elettromandri e su macchine per il legno.
- Rotazione simmetrica senza chiavette di trascinamento.
- Coppia trasmessa solo per attrito tra le superfici.
- Adduzione refrigerante dal centro

Form E

- Anwendung für Hochfrequenzspindeln, Holzbearbeitungsmaschinen.
- Rotations-symmetrisch, ohne Mitnehmernuten.
- Drehmomentübertragung über Reibschluss.
- Zentrale Kühlmittelzufuhr über Kühlmittelrohr möglich.

Forme E

- Utilisation pour des broches à hautes fréquences, les machines à usiner le bois.
- Symétrie de rotation, sans gorges d'entraînement.
- Transmission du couple par friction.
- Possibilité d'alimentation centrale du liquide de lubrification par tube d'arrosage.

Исполнение E

- Применяются в высокоскоростных шпинделях и деревообрабатывающих станках.
- Конструкция без шпоночных пазов.
- Передача крутящего момента осуществляется посредством силы трения.
- Возможна подача СОЖ через центральный канал оправки.

Form E

- 用于高频率轴及木材加工。
- 对称旋转,没有键槽。
- 通过摩擦阻力传输扭矩。
- 通过冷却剂管道来进行中央冷却剂供应。

CONE'S TOLERANCE TOLLERANZA DEL CONO
 KEGELSCHAFTTOLERANZEN TOLERANCE DU CONE
 ТОЧНОСТЬ КОНЫА 锥体误差

DIN 69893 E

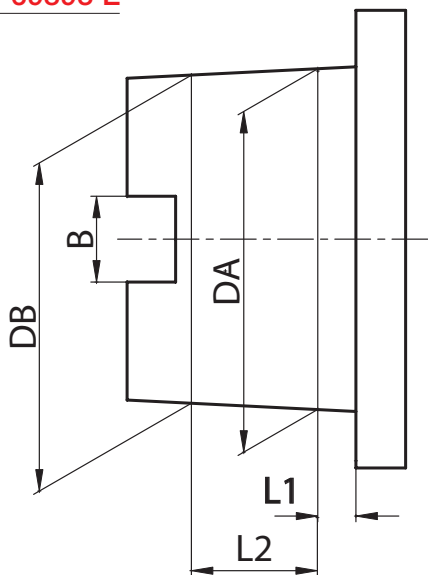

HSK	L1	L2	D.A.	D.B.	B (only type A+C)	
25 A+C+E	2,5	8,5	19	+0.005 +0.007	18,15 +0.003 +0.005	6.05 +/- 0.04
32 A+C	3,2	7.03	24	+0.005 +0.007	23,27 +0.003 +0.005	7.05 +/- 0.04
40 A+C+E	4	9.05	30	+0.005 +0.007	29,05 +0.003 +0.005	8.05 +/- 0.04
40 B+D	3,2	7.03	24	+0.005 +0.007	23,27 +0.003 +0.005	-
50 A+C+E	5	11	38	+0.006 +0.009	36,9 +0.003 +0.006	10.54 +/- 0.04
50 B+D+F	4	9.05	30	+0.005 +0.007	29,05 +0.003 +0.005	-
63 A+C+E	6,3	14.07	48	+0.007 +0.011	46,53 +0.003 +0.007	12.54 +/- 0.04
63 B+D+F	5	11	38	+0.006 +0.009	36,9 +0.003 +0.006	-
100 A+C	10	24	75	+0.009 +0.015	72,6 +0.003 +0.009	20.02 +/- 0.04
100 B+D	8	19	60	+0.008 +0.013	58,1 +0.003 +0.008	-



KINTEK TOOLHOLDERS

All KINTEK toolholders are manufactured according to DIN norms.
 (these norms provide the same classes of tolerance for the attachment DIN69893 A+C, B+D, E, F)

COLLET CHUCK'S RUNOUT ACCURACY

The norm DIN 69882-6 permits a runout error of 0,005 mm. for DIN6499/ISO15488 collet chucks.

SHELL END MILL ADAPTOR'S RUNOUT ACCURACY

Our shell end mill adaptors meet the requirements of the norm DIN 69882-2, which prescribes for diameters Ø 16,22,27,32 a runout accuracy of 0,01

WELDON END MILL HOLDER'S RUNOUT ACCURACY

According to norm DIN 69882-4 Weldon end mill holders have to meet the following requirements: Bore: H5 / Runout accuracy: 0.005.

CONSTRUCTIVE FEATURES

- Manufactured with Casehardening Steel.
- Casehardened with depth 0,4 - 0,5 mm
- Hardened-Tempered
- Hardness HRC 58+-2, Strength 800-1000 N/mm2
- Black oxidized
- Thread of collet nuts, internal and external diameters are completely grinding finished
- Tested 100% with certified measuring instruments.



MANDRINI KINTEK CON ATTACCO HSK

Tutti i mandrini portautensili KINTEK vengono prodotti secondo le normative DIN (dette normative prevedono le stesse classi di tolleranza per gli attacchi DIN69893 A+C, B+D, E, F)

COASSIALITÀ PORTAPINZA

La normativa DIN 69882-6. ammette un'errore massimo di 0,005 mm. per i portapinze DIN6499/ISO15488

COASSIALITÀ PORTAFRESE FISSI E COMBINATI

I portafrese fissi e combinati rispondono ai criteri prescritti dalla norma DIN 69882-2 la quale prevede per i Ø 16,22,27,32 una coassialità di 0,01

COASSIALITÀ PORTAFRESE WELDON

Secondo la normativa DIN 69882-4 il portafrese WELDON deve rispondere ai seguenti requisiti: Foro: H5 / Coassialità: 0.005.

DATI COSTRUTTIVI

- Costruiti in acciaio da cementazione legato.
- Cementati con profondità 0,4 - 0,5 mm
- Temprati-rinvenuti
- Durezza HRC 58 +- 2 resistenza 800-1000 N/mm2
- Bruniti
- Finitura di rettifica interna, esterna e nelle filettature delle ghiere chiudipinza
- Collaudati 100% con strumenti di misura certificati.



STEILKEGELAUFNHMEN KINTEK HSK

Alle KINTEK - Steilkegelaufnahmen werden nach den DIN - Normen angefertigt.
 (Diese Normen sehen die gleichen Toleranzklassen für die DIN 69893 A+C, B+D, E, F Aufnahmen vor)

SPANNZANGENAUFNAHME RUNDLAUFGENAUIGKEIT

Die DIN69882-6 Norm schreibt eine Rundlaufgenauigkeit zwischen Aussenkegel und Innenkegel / Spannzangensitz für die DIN6499/ISO15488- Spannzangenaufnahmen von 0,005 vor.

AUFSTECKFRÄSDORNE - RUNDLAUFGENAUIGKEIT

Kintek-Aufsteckfräsdorne entsprechen der DIN 69882-2 Norm, die für die Ø 16,22,27,32 eine Rundlaufgenauigkeit von 0,01 vorsieht.

WELDON - AUFSTECKFRÄSDORNE - RUNDLAUFGENAUIGKEIT

Nach der DIN 69882-4 Norm muß der Weldon- Aufsteckfräsdorn die folgenden Forderungen aufweisen: Bohrung: H5 / Rundlaufgenauigkeit: 0.005.

KONSTRUKTIONSDATEN

- aus legiertem Einsatzstahl angefertigt
- in der Einsatzhärte von 0,4 - 0,5 mm
- gehärtet, angelassen
- Härte HRC58 +-2, Festigkeit 800-1000 N/mm2
- brüniert
- inneres, äußeres Schleifen und am Gewinde der Spannzangenmutter
- 100% durch zertifizierte Meßinstrumente geprüft.

CONE'S TOLERANCE TOLLERANZA DEL CONO
KEGELSCHAFTTOLERANZEN TOLERANCE DU CONE
ТОЧНОСТЬ КОНУСА 锥体误差

DIN 69893 E

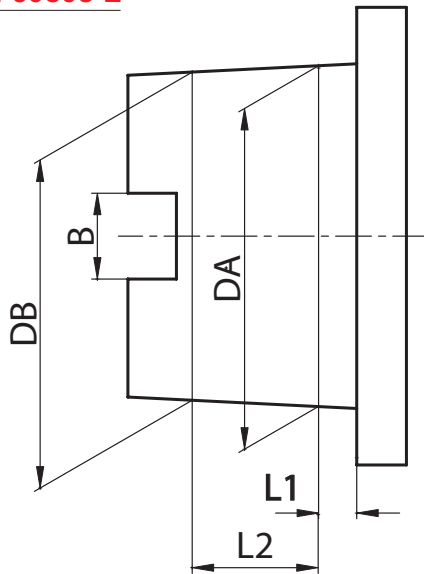

HSK	L1	L2	D.A.		D.B.		B (only type A+C)
25 A+C+E	2,5	8,5	19	+0.005 +0.007	18,15	+0.003 +0.005	6.05 +/- 0.04
32 A+C	3,2	7.03	24	+0.005 +0.007	23,27	+0.003 +0.005	7.05 +/- 0.04
40 A+C+E	4	9.05	30	+0.005 +0.007	29,05	+0.003 +0.005	8.05 +/- 0.04
40 B+D	3,2	7.03	24	+0.005 +0.007	23,27	+0.003 +0.005	-
50 A+C+E	5	11	38	+0.006 +0.009	36,9	+0.003 +0.006	10.54 +/- 0.04
50 B+D+F	4	9.05	30	+0.005 +0.007	29,05	+0.003 +0.005	-
63 A+C+E	6,3	14.07	48	+0.007 +0.011	46,53	+0.003 +0.007	12.54 +/- 0.04
63 B+D+F	5	11	38	+0.006 +0.009	36,9	+0.003 +0.006	-
100 A+C	10	24	75	+0.009 +0.015	72,6	+0.003 +0.009	20.02 +/- 0.04
100 B+D	8	19	60	+0.008 +0.013	58,1	+0.003 +0.008	-



MANDRINS KINTEK HSK

Tous les mandrins porte-outils KINTEK sont fabriqués selon les normes DIN (qui prévoient les mêmes classes de tolérance pour les attachement DIN69893 A+C, B+D, E, F)

COAXIALITE' PORTE-PINCE

La norme DIN 69882-6 permet une erreur de 0,005 mm. Maximum pour les porte-pinces DIN6499/ISO15488

COAXIALITE' PORTE-FRAISES FIXES ET COMBINES

Les porte-fraises fixes et combinés suivent les spécifications de la norme DIN 69882-2 qui prévoit pour les diamètres Ø 16,22,27,32 une coaxialité de 0,01

COAXIALITE' PORTE-FRAISES WELDON

Suivant les spécifications DIN 69882-4 les porte-fraises WELDON doivent suivre les conditions suivantes: Trou: H5 / Coaxialité: 0.005.

ELEMENTS DE CONSTRUCTION

- Produits en acier cémenté allié.
- Cémentés avec une profondeur 0,4 - 0,5 mm
- Trempés - Revenus
- Dureté HRC 58 +/- 2 résistance 800-1000 N/mm2
- Brunis
- Rectification du cône intérieur, extérieur et dans le filetage des écrous qui serrent la pince.
- Contrôlés à 100 % avec des instruments de mesure certifiés.



ОПРАВКИ KINTEK

Все оправки Kintek произведены согласно стандарту DIN.

(Эти нормы обеспечивают тот же класс точности как DIN 6983 A+C, B+D, E, F)

БИЕНИЕ ЦАНГОВЫХ ПАТРОНОВ

В соответствии с нормами DIN 69882-6, допустимое биение составляет 0,005 мм для цанговых патронов по DIN6499/ISO15488.

БИЕНИЕ ОПРАВОК ДЛЯ НАСАДНЫХ ФРЕЗ

Патроны изготовлены в соответствии с требованиями DIN 69882-2, согласно которым биение для диаметров 16-22-27-32-40 составляет 0,01.

БИЕНИЕ ПАТРОНОВ С КРЕПЛЕНИЕМ WELDON

Оправки соответствуют следующим требованиям DIN 69882-4: Точность отверстия: H5 / Биение: 0,005

КОНСТРУКТИВНЫЕ ОСОБЕННОСТИ

- Изготовлены из стали с последующей цементацией
- Цементация на глубину 0,4 - 0,5 мм
- Оправки подвергнуты закалке и отпуску
- Твердость 58 +/- 2 HRC, прочность 800-1000 Н/мм2
- Защитно-декоративное покрытие черного цвета
- Шлифованные внешние и внутренние диаметры, а также резьба гаек цанговых патронов.
- Каждая оправка испытана на сертифицированном оборудовании



KINTEK 刀柄

所有 KINTEK 刀柄均是根据 DIN 标准制造的。

(这些标准规定了与附件 DIN69893 A+C, B+D, E, F 相同级别的误差)。

弹簧夹头的径向跳动精度

DIN69882-6 标准允许 DIN6499/ISO15488 弹簧夹头的径向跳动误差为 0.005 毫米。

平面铣接头的径向跳动精度

我公司的平面铣接头满足 DIN 69882-2 标准要求, 该标准规定了直径为 16, 22, 27, 32 的径向跳动精度为 0.01。

威尔登端铣夹具的径向跳动精度

根据 DIN 69882-4 标准规定, 威尔登端铣夹具必须要达到下列要求: 孔: H5 / 径向跳动精度: 0.005。

结构特点

- 用表面硬化钢材制造。
- 硬化深度达 0.4 - 0.5 毫米。
- 经过硬化及回火处理。
- 硬度达 HRC 58 +/- 2, 强度达 800-1000 N / 平方毫米。
- 黑色氧化
- 夹头螺母螺纹, 内径和外径均完成表面打磨处理。
- 100% 使用经过认证的测量仪器检测。

ER COLLET CHUCKS MANDRINI PORTAPINZA TIPO ER
 SPANNZANGENFUTTER ER TYPE MANDRINS A PINCES TYPE ER
 ЦАНГОВЫЕ ПАТРОНЫ ER ER 弹簧夹头

DIN 69893 E - DIN6499/ISO15488

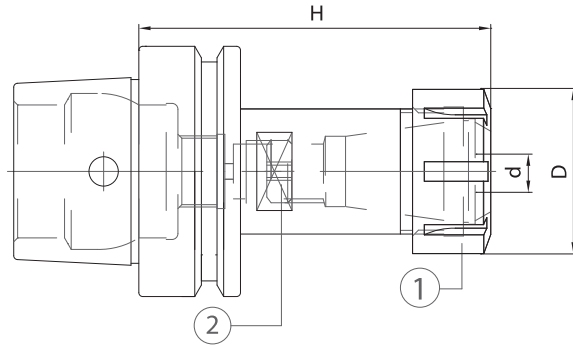

HSK	CODE N.	DESCRIPTION	H	d	D	ER	L	D3	G2,5 20000 RPM	
STANDARD	25	214-37344	HSK25EH43ER16M	43	0,5÷10	22	16M	-	-	•
	32	214-37377	HSK32EH60ER16M	60	0,5÷10	22	16M	-	-	•
	32	214-37378	HSK32EH60ER25M	60	1÷16	35	25M	-	-	•
	40	214-37301	HSK40EH70ER16M	70	0,5÷10	22	16M	-	-	•
	40	214-37302	HSK40EH80ER25M	80	1÷16	35	25M	-	-	•
	50	214-37303	HSK50EH80ER16M	80	0,5÷10	22	16M	-	-	•
	50	214-37304	HSK50EH95ER25	95	1÷16	42	25	32	40	•
	50	214-37305	HSK50EH100ER32	100	2÷20	50	32	33	42	•
	63	214-37306	HSK63EH90ER16M	90	0,5÷10	22	16M	-	-	•
	63	214-37307	HSK63EH90ER25	90	1÷16	42	25	31	39	•
	63	214-37308	HSK63EH100ER32	100	2÷20	50	32	35	48	•
	63	214-37309	HSK63EH80ER40	80	3÷30	63	40	-	-	•

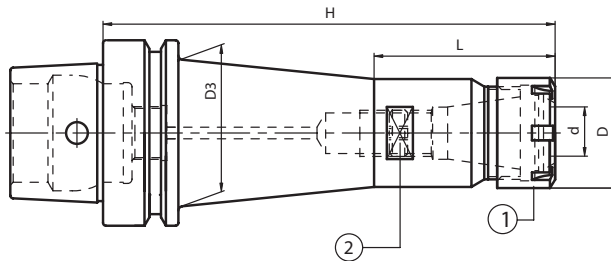

HSK	CODE N.	DESCRIPTION	H	d	D	ER	L	D3	G2,5 20000 RPM	
EXT.	40	214-37311	HSK40EH120ER16M	120	0,5÷10	22	16M	47	29	•
	50	214-37313	HSK50EH150ER16M	150	0,5÷10	22	16M	47	40	•
	63	214-37316	HSK63EH160ER16M	160	0,5÷10	22	16M	47	39	•

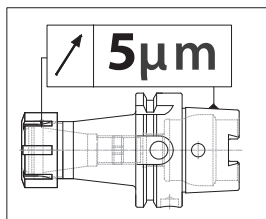

Spare parts • Componenti • Ersatzteile • Pièces détachées
 Запасные части • 零件

ER	NUT	STOP SCREW	WRENCH
16M	812-203013	811-303119	816-203009
25M	812-203015	811-303121	816-203011
25	812-203001	811-303121	816-203001
32	812-203002	811-303118	816-203002
40/H120	812-203003	811-303122	816-203003
40/H80	812-203003	-	816-203003

FACE MILL HOLDERS-TENONS DRIVE
AUFSTECKFRÄSDORNE FÜR FRÄSER MIT QUERNUT
ОПРАВКИ ДЛЯ НАСАДНЫХ ФРЕЗ

MANDRINI PORTAFRESE A TRASCINAMENTO FISSO
MANDRINS PORTE-FRAISES-ENTRAÎNEMENT PAR TENONS
平面铣刀柄 - 凸榫驱动

DIN 69893 E - ISO 3937

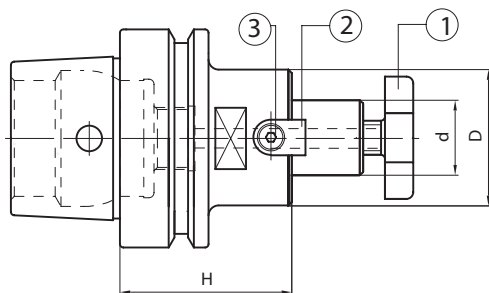

HSK	CODE N.	DESCRIPTION	H	d	D	G2,5 20000 RPM
40	216-77301	HSK40EH45D16F	45	16	38	•
40	216-77302	HSK40EH50D22F	50	22	48	•
63	216-77309	HSK63EH50D22F	50	22	48	•
63	216-77310	HSK63EH55D27F	55	27	58	•

Spare parts • Componenti • Ersatzteile • Pièces détachées • Запасные части • 零件

d	CROSS SCREW	CROSS SCREW ON ENQUIRY	DOG	SCREW	WRENCH
16	811-107003	811-107013	814-202280	811-101004	816-130002
22	811-107004	811-107014	814-202250	811-101011	816-130003
27	811-107005	811-107015	814-202270	811-101018	816-130004
32	811-107006	811-107016	814-202630	811-101029	816-130005
40	811-107007	811-107017	814-202710	811-101029	816-130006

BLANK TOOLHOLDERS WITH SOFT SHANK
ROHLINGE MIT WEICHEM SCHAFT
ЗАГОТОВКИ ДЛЯ ОПРАВОК НЕЗАКАЛЕННЫЕ

MANDRINI SEMILAVORATI A STELO TENERO
BARRES D'ALEPAGE SEMI-FINIES
带软柄的切断刀柄

DIN 69893 E

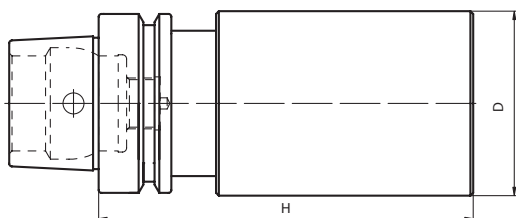

HSK	CODE N.	DESCRIPTION	H	D
63	217-17303	HSK63EH200D63SM	200	63

HRC26-28



DIN 69893 F



TAPER SHANKS DATA SHEET DATI TECNICI CONI D'ATTACCO
 TECHNISCHE DATEN DER STEILKEGELWERKZEUGE DONNEES TECHNIQUES QUEUE D'OUTILS
 КОНСТРУКТИВНЫЕ РАЗМЕРЫ 锥柄数据表

DIN 69893 F

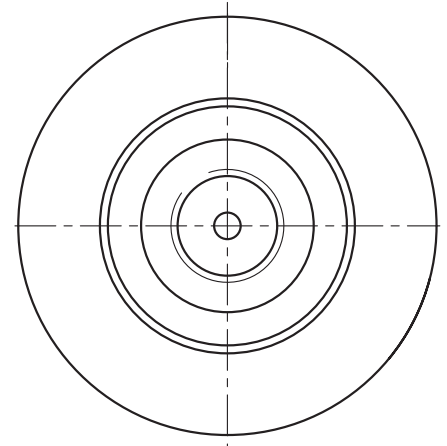
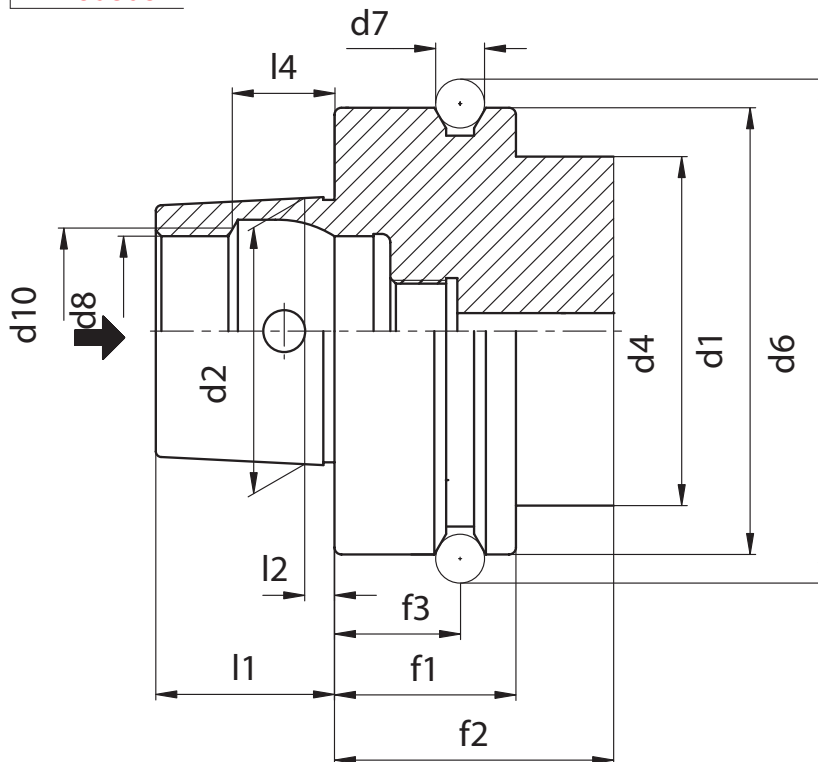

	HSK 50	HSK 63
d1	50	63
d2	30	38
d4	42	53
d6	59,3	72,3
d7	7	7
d8	21	26
d10	23	29
f1	26	26
f2	42	42
f3	18	18
l1	20	25
l2	4	5
l4	11,42	14,13

Form F

- Used for high frequency spindles and wood machining.
- With larger collar.
- Central coolant supply possible through coolant hose.

Forma F

- Usato su elettromandri e su macchine per il legno.
- Con flangia maggiorata.
- Adduzione refrigerante al centro.

Form F

- Anwendung für Hochfrequenzspindeln, Holzbearbeitungsmaschinen.
- Mit vergrößertem Bund.
- Zentrale Kühlmittelzufuhr über Kühlmittelrohr möglich.

Forme F

- Utilisation pour des broches à hautes fréquences, les machines à usiner le bois.
- Avec épaulement agrandi.
- Possibilité d'alimentation centrale du liquide de lubrification par tube d'arrosage.

Исполнение F

- Применяются в высокоскоростных шпинделях и деревообрабатывающих станках.
- Усиленный фланец.
- Возможна подача СОЖ через центральный канал оправки.

Form F

- 用于高频率轴及木材加工。
- 具备大项圈。
- 可通过冷却剂管道进行中央冷却剂供应。

CONE'S TOLERANCE
KEGELSCHAFTTOLERANZEN
ТОЧНОСТЬ КОНЫ
TOLLERANZA DEL CONO
TOLERANCE DU CONE
锥体误差

DIN 69893 F

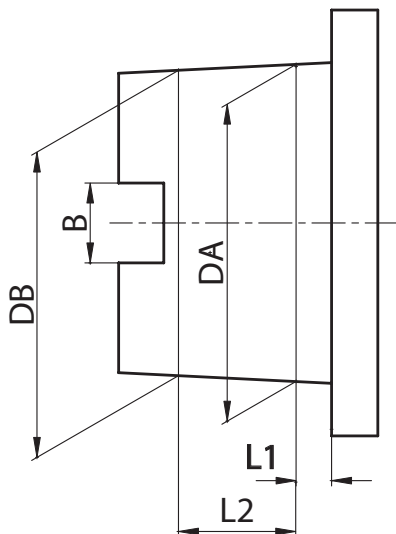

HSK	L1	L2	D.A.		D.B.		B (only type A+C)
32 A+C	3,2	7,3	24	+0.005 +0.007	23,27	+0.003 +0.005	7.05 +/- 0.04
40 A+C+E	4	9,5	30	+0.005 +0.007	29,05	+0.003 +0.005	8.05 +/- 0.04
40 B+D	3,2	7,3	24	+0.005 +0.007	23,27	+0.003 +0.005	-
50 A+C+E	5	11	38	+0.006 +0.009	36,9	+0.003 +0.006	10.54 +/- 0.04
50 B+D+F	4	9,5	30	+0.005 +0.007	29,05	+0.003 +0.005	-
63 A+C+E	6,3	14,7	48	+0.007 +0.011	46,53	+0.003 +0.007	12.54 +/- 0.04
63 B+D+F	5	11	38	+0.006 +0.009	36,9	+0.003 +0.006	-
100 A+C	10	24	75	+0.009 +0.015	72,6	+0.003 +0.009	20.02 +/- 0.04
100 B+D	8	19	60	+0.008 +0.013	58,1	+0.003 +0.008	-



KINTEK TOOLHOLDERS

All KINTEK toolholders are manufactured according to DIN norms.
(these norms provide the same classes of tolerance for the attachment DIN69893 A+C, B+D, E, F)

COLLET CHUCK'S RUNOUT ACCURACY
The norm DIN 69882-6 permits a runout error of 0,005 mm. for DIN6499/ISO15488 collet chucks.

SHELL END MILL ADAPTOR'S RUNOUT ACCURACY
Our shell end mill adaptors meet the requirements of the norm DIN 69882-2, which prescribes for diameters Ø 16,22,27,32 a runout accuracy of 0,01

WELDON END MILL HOLDER'S RUNOUT ACCURACY
According to norm DIN 69882-4 Weldon end mill holders have to meet the following requirements: Bore: H5 / Runout accuracy: 0.005.

CONSTRUCTIVE FEATURES

- Manufactured with Casehardening Steel.
- Casehardened with depth 0,4 - 0,5 mm
- Hardened-Tempered
- Hardness HRC 58+-2, Strength 800-1000 N/mm2
- Black oxidized
- Thread of collet nuts, internal and external diameters are completely grinding finished
- Tested 100% with certified measuring instruments.



MANDRINI KINTEK CON ATTACCO HSK

Tutti i mandrini portautensili KINTEK vengono prodotti secondo le normative DIN (dette normative prevedono le stesse classi di tolleranza per gli attacchi DIN69893 A+C, B+D, E, F)

COASSIALITÀ PORTAPINZA
La normativa DIN 69882-6. ammette un'errore massimo di 0,005 mm. per i portapinze DIN6499/ISO15488

COASSIALITÀ PORTAFRESE FISSI E COMBINATI
I portafrese fissi e combinati rispondono ai criteri prescritti dalla norma DIN 69882-2 la quale prevede per i Ø 16,22,27,32 una coassialità di 0,01

COASSIALITÀ PORTAFRESE WELDON
Secondo la normativa DIN 69882-4 il portafrese WELDON deve rispondere ai seguenti requisiti: Foro: H5 / Coassialità: 0.005.

DATI COSTRUTTIVI

- Costruiti in acciaio da cementazione legato.
- Cementati con profondità 0,4 - 0,5 mm
- Temprati-rinvenuti
- Durezza HRC 58 +- 2 resistenza 800-1000 N/ mm2
- Bruniti
- Finitura di rettifica interna, esterna e nelle filettature delle ghiera chiudipinza
- Collaudati 100% con strumenti di misura certificati.



STEILGEKELAUFNHMEN KINTEK HSK

Alle KINTEK - Steilgekelaufnahmen werden nach den DIN - Normen angefertigt.
(Diese Normen sehen die gleichen Toleranzklassen für die DIN 69893 A+C, B+D, E, F Aufnahmen vor)

SPANNZANGENAUFNAHME RUNDLAUFGENAUIGKEIT
Die DIN69882-6 Norm schreibt eine Rundlaufgenauigkeit zwischen Aussenkegel und Innenkegel / Spannzangensitz für die DIN6499/ISO15488- Spannzangenaufnahmen von 0,005 vor.

AUFSTECKFRÄSDORNE - RUNDLAUFGENAUIGKEIT
Kintek-Aufsteckfräsdorne entsprechen der DIN 69882-2 Norm, die für die Ø 16,22,27,32 eine Rundlaufgenauigkeit von 0,01 vorsieht.

WELDON - AUFSTECKFRÄSDORNE - RUNDLAUFGENAUIGKEIT
Nach der DIN 69882-4 Norm muß der Weldon- Aufsteckfräsdorn die folgenden Forderungen aufweisen: Bohrung: H5 / Rundlaufgenauigkeit: 0.005.

KONSTRUKTIONSDATEN

- aus legiertem Einsatzstahl angefertigt
- in der Einsatzhärtetiefe von 0,4 - 0,5 mm zementiert
- gehärtet, angelassen
- Härte HRC58 +-2, Festigkeit 800-1000 N/mm2
- brüniert
- inneres, äußeres Schleifen und am Gewinde der Spannzangemutter
- 100% durch zertifizierte Meßinstrumente geprüft.

CONE'S TOLERANCE
KEGELSCHAFTTOLERANZEN
ТОЧНОСТЬ КОНУСА
TOLLERANZA DEL CONO
TOLERANCE DU CONE
锥体误差

DIN 69893 F

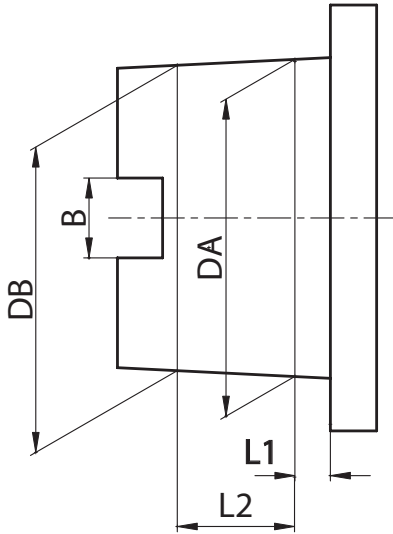

HSK	L1	L2	D.A.		D.B.		B (only type A+C)
32 A+C	3,2	7,3	24	+0.005 +0.007	23,27	+0.003 +0.005	7.05 +/- 0.04
40 A+C+E	4	9,5	30	+0.005 +0.007	29,05	+0.003 +0.005	8.05 +/- 0.04
40 B+D	3,2	7,3	24	+0.005 +0.007	23,27	+0.003 +0.005	-
50 A+C+E	5	11	38	+0.006 +0.009	36,9	+0.003 +0.006	10.54 +/- 0.04
50 B+D+F	4	9,5	30	+0.005 +0.007	29,05	+0.003 +0.005	-
63 A+C+E	6,3	14,7	48	+0.007 +0.011	46,53	+0.003 +0.007	12.54 +/- 0.04
63 B+D+F	5	11	38	+0.006 +0.009	36,9	+0.003 +0.006	-
100 A+C	10	24	75	+0.009 +0.015	72,6	+0.003 +0.009	20.02 +/- 0.04
100 B+D	8	19	60	+0.008 +0.013	58,1	+0.003 +0.008	-



MANDRINS KINTEK HSK

Tous les mandrins porte-outils KINTEK sont fabriqués selon les normes DIN (qui prévoient les mêmes classes de tolérance pour les attachement DIN69893 A+C, B+D, E, F)

COAXIALITE' PORTE-PINCE

La norme DIN 69882-6 permet une erreur de 0,005 mm. Maximum pour les porte-pinces DIN6499/ISO15488

COAXIALITE' PORTE-FRAISES FIXES ET COMBINES

Les porte-fraises fixes et combinés suivent les spécifications de la norme DIN 69882-2 qui prévoit pour les diamètres Ø 16,22,27,32 une coaxialité de 0,01

COAXIALITE' PORTE-FRAISES WELDON

Suivant les spécifications DIN 69882-4 les porte-fraises WELDON doivent suivre les conditions suivantes: Trou: H5 / Coaxialité: 0.005.

ELEMENTS DE CONSTRUCTION

- Produits en acier cémenté allié.
- Cémentés avec une profondeur 0,4 - 0,5 mm
- Trempés - Revenus
- Dureté HRC 58 +/- 2 résistance 800-1000 N/mm2
- Brunis
- Rectification du cône intérieur, extérieur et dans le filetage des écrous qui serrent la pince.
- Contrôlés à 100 % avec des instruments de mesure certifiés.



ОПРАВКИ KINTEK

Все оправки Kintek произведены согласно стандарту DIN.

(Эти нормы обеспечивают тот же класс точности как DIN 6983 A+C, B+D, E, F)

БИЕНИЕ ЦАНГОВЫХ ПАТРОНОВ

В соответствии с нормами DIN 69882-6, допустимое биение составляет 0,005 мм для цанговых патронов по DIN6499/ISO15488.

БИЕНИЕ ОПРАВОК ДЛЯ НАСАДНЫХ ФРЕЗ

Патроны изготовлены в соответствии с требованиями DIN 69882-2, согласно которым биение для диаметров 16-22-27-32-40 составляет 0,01.

БИЕНИЕ ПАТРОНОВ С КРЕПЛЕНИЕМ WELDON

Оправки соответствуют следующим требованиям DIN 69882-4: Точность отверстия: H5 / Биение: 0,005

КОНСТРУКТИВНЫЕ ОСОБЕННОСТИ

- Изготовлены из стали с последующей цементацией
- Цементация на глубину 0,4 - 0,5 мм
- Оправки подвергнуты закалке и отпуску
- Твердость 58 +/- 2 HRC, прочность 800-1000 Н/мм2
- Защитно-декоративное покрытие черного цвета
- Шлифованные внешние и внутренние диаметры, а также резьба гаек цанговых патронов.
- Каждая оправка испытана на сертифицированном оборудовании



KINTEK 刀柄

所有 KINTEK 刀柄均是根据 DIN 标准制造的。

(这些标准规定了与附件 DIN69893 A+C, B+D, E, F 相同级别的误差)。

弹簧夹头的径向跳动精度

DIN69882-6 标准允许 DIN6499/ISO15488 弹簧夹头的径向跳动误差为 0,005 毫米。

平面铣接头的径向跳动精度

我公司的平面铣接头满足 DIN69882-2 标准要求, 该标准规定了直径为 16, 22, 27, 32 的径向跳动精度为 0, 01。

威尔登端铣夹具的径向跳动精度

根据 DIN 69882-4 标准规定, 威尔登端铣夹具必须要达到下列要求:

孔: H5

径向跳动精度: 0.005.

结构特点

- 用表面硬化钢材制造。
- 硬化深度达 0,4 - 0,5 毫米。
- 经过硬化及回火处理。
- 硬度达 HRC 58 +/- 2, 强度达 800-1000 N / 平方毫米。
- 黑色氧化。
- 夹头螺母的螺纹, 内径和外径均进行了表面打磨处理。
- 100% 使用经过认证的测量仪器检测。

ER COLLET CHUCKS MANDRINI PORTAPINZA TIPO ER
 SPANNZANGENFUTTER ER TYPE MANDRINS A PINCES TYPE ER
 ЦАНГОВЫЕ ПАТРОНЫ ER ER 弹簧夹头

DIN 69893 F - DIN6499/ISO15488

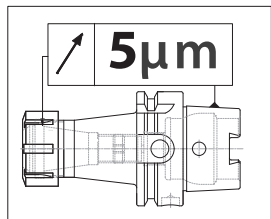
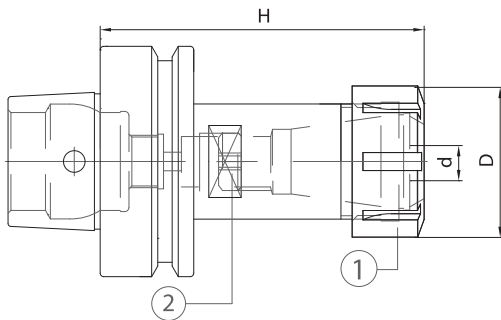

HSK	CODE N.	DESCRIPTION	H	d	D	ER	L	D3	G2,5 30000 RPM
50	214-37401	HSK50FH80ER16M	80	0,5÷10	22	16M	-	-	•
50	214-37402	HSK50FH80ER25	80	1÷16	42	25	-	-	•
63	214-37404	HSK63FH100ER16M	100	0,5÷10	22	16M	47	26	•
63	214-37405	HSK63FH100ER25	100	1÷16	42	25	32	41	•
63	214-37406	HSK63FH100ER32	100	2÷20	50	32	35	46	•
63	214-37411	HSK63FH160ER16M	160	0,5÷10	22	16M	57	35	•
63	214-37413	HSK63FH160ER32	160	2÷20	50	32	78	48	•
63	214-37407	HSK63FH80ER40	80	3÷30	63	40	-	-	•

Spare parts • Componenti • Ersatzteile • Pièces détachées
 Запасные части • 零件

ER	NUT	STOP SCREW	WRENCH
16M	812-203013	811-303119	816-203009
25M	812-203015	811-303121	816-203011
25	812-203001	811-303121	816-203001
32	812-203002	811-303118	816-203002
40/H120	812-203003	811-303122	816-203003
40/H68;80	812-203003	-	816-203003

END MILL HOLDERS WELDON MANDRINI PORTAFRESE TIPO WELDON
 ZYLINDERSCHAFTAUFNAHME WELDON MANDRINS POUR OUTILS TYPE WELDON
 ОПРАВКИ С КРЕПЛЕНИЕМ WELDON 威尔登式端铣夹具

DIN 69893 F - DIN 1835/B

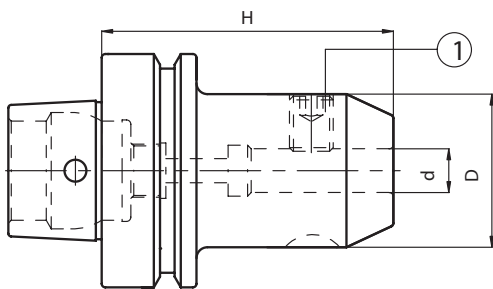

HSK	CODE N.	DESCRIPTION	H	d	D	G2,5 20000 RPM
63	213-17410	HSK63FH80WE12	80	12	42	•
63	213-17411	HSK63FH80WE16	80	16	48	•
63	213-17412	HSK63FH85WE20	85	20	52	•
63	213-17413	HSK63FH110WE25	110	25	65	•

Spare parts • Componenti • Ersatzteile
 Pièces détachées • Запасные части • 零件

d	LOCKING SCREW	QUANTITY
6	811-106001	1
8	811-106002	1
10	811-106004	1
12	811-106005	1
16	811-106006	1
20	811-106007	1
25	811-106008	2

FACE MILL HOLDERS-TENONS DRIVE
AUFSTECKFRÄSDORNE FÜR FRÄSER MIT QUERNUT
ОПРАВКИ ДЛЯ НАСАДНЫХ ФРЕЗ

MANDRINI PORTAFRESE A TRASCINAMENTO FISSO
MANDRINS PORTE-FRAISES-ENTRAÎNEMENT PAR TENONS
平面铣刀柄 - 凸榫驱动

DIN 69893 F - ISO 3937

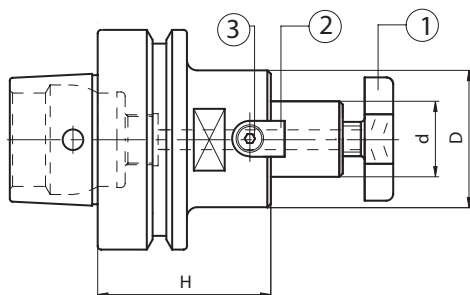

HSK	CODE N.	DESCRIPTION	H	d	D	G2,5 20000 RPM
63	216-77404	HSK63FH45D16F	45	16	38	•
63	216-77405	HSK63FH50D22F	50	22	48	•
63	216-77406	HSK63FH55D27F	55	27	58	•
63	216-77407	HSK63FH60D32F	60	32	78	•
63	216-77408	HSK63FH65D40F	65	40	88	•

Spare parts • Componenti • Ersatzteile • Pièces détachées • Запасные части • 零件

d	CROSS SCREW	CROSS SCREW ON ENQUIRY	DOG	SCREW	WRENCH
16	811-107003	811-107013	814-202280	811-101004	816-130002
22	811-107004	811-107014	814-202250	811-101011	816-130003
27	811-107005	811-107015	814-202270	811-101018	816-130004
32	811-107006	811-107016	814-202630	811-101029	816-130005
40	811-107007	811-107017	814-202710	811-101029	816-130006

BLANK TOOLHOLDERS WITH SOFT SHANK
ROHLINGE MIT WEICHEM SCHAFT
ЗАГОТОВКИ ДЛЯ ОПРАВОК НЕЗАКАЛЕННЫЕ

MANDRINI SEMILAVORATI A STELO TENERO
EBAUCHE
带软柄的切断刀柄

DIN 69893 F

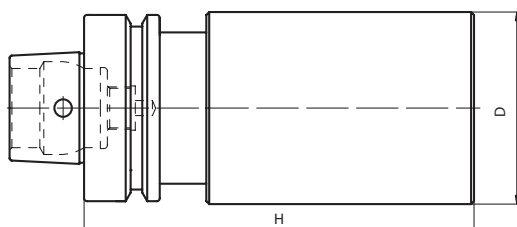

HSK	CODE N.	DESCRIPTION	H	D
63	217-17402	HSK63FH200D63SM	200	63

HRC26-28

CLAMPING FINGERS PINZE
GREIFER PINCES
ЗАХВАТЫ 夹具

		Codice/Code	Peso del mandrino / Toolholder 's weight			Lunghezza del mandrino (mm) Tool's length (mm)	Molla/Spring	
			Max. Load in vertical Pos. (kg)	Max. Load in upper Pos. (kg)	Max. Load in lower Pos. (kg)			
CAS-HSK63A		832-018030	14,6	7,8	4,1	250	SN 2540-16-76	A
		832-018470	21	11,2	5,9	250	SN 2560-16-76	B
CAS-HSK100A		832-018020	40	20,5	11	400	SDF600-20x102	A
		832-018480	80	50	27	400	SDF700-20x102	B
CAS-C6		832-007940	15,6	8,3	4,4	250	SN 2540-16-76	A
		832-018490	22,3	11,9	6,3	250	SN 2560-16-76	B
CAS-C8		832-018050	18,2	10,5	5,1	250	SDF600-16x89	A
		832-018500	29	16,7	8,2	250	SDF700-16x89	B
CAS-KM 63-2		832-007980	14,4	7,7	4	250	SN 2540-16-76	A
		832-018510	20,5	10,9	5,8	250	SN 2560-16-76	B
CAS-TC 40		832-018520	14,6	7,8	4,1	250	SN 2540-16-76	A
		832-018530	21	11,2	5,9	250	SN 2560-16-76	B
CAS-TC50		832-018360	25	13	7	400	SDF500-20x102	C
		832-018210	40	27	15	400	SDF600-20x102	A
CAS-BT 40		832-018540	14,6	7,8	4,1	250	SN 2540-16-76	A
		832-018550	21	11,2	5,9	250	SN 2560-16-76	B
CAS-BT 50		832-018370	25	13	7	400	SDF500-20x102	C
		832-018200	61	31	17	400	SDF600-20x102	A

A Middle Strength Spring

Molla Forza Media
Mittelkraft Feder
Ressort moyen force
Пружина средней жесткости
中等强度的弹簧

B Stiffened Spring

Molla Rinforzata
Verstärkte Feder
Ressort renforcé
Пружина повышенной жесткости
强化弹簧

C Normal Spring

Molla Normale
Normale Feder
Ressort normal
Пружина нормальной жесткости
正常弹簧

CLAMPING FINGERS FOR TOOL MAGAZINES PINZE ALLOGGIAMENTO PORTAUTENSILI PER MAGAZZINI MACCHINE UTENSILI
 GREIFER FÜR WERKZEUGMAGAZIN PINCES DE LOGEMENT POUR LE MAGASIN DES MACHINES OUTILS
 ЗАХВАТЫ ДЛЯ ИНСТРУМЕНТАЛЬНОГО МАГАЗИНА 刀具库使用的夹具

DIN 69893 F

CLAMPING FINGERS FOR TOOL MAGAZINES

Thanks to our constant and exhaustive co-operation with the most famous machine tool makers we develop a very good experience into the manufacturing of high precision clamping fingers for toolmagazines. Our range includes clampers for the most popular attachments: ISO CONES, HSK Holders but of course we are open to any new version, according to the customer's drawing.

PINZE ALLOGGIAMENTO PORTAUTENSILI PER MAGAZZINI MACCHINE UTENSILI

Grazie alla nostra costante ed intensa collaborazione con i più famosi costruttori di macchine utensili, abbiamo sviluppato una buona esperienza nella produzione di Pinze ad alta precisione per l'alloggiamento nei magazzini di macchine utensili. Nella nostra gamma sono presenti attacchi: ISO, HSK ed altri, e naturalmente siamo aperti ad altre versioni secondo disegno del cliente.

GREIFER FÜR WERKZEUGMAGAZIN

Dank unserer intensiven und engen Zusammenarbeit mit den berühmtesten Maschinenherstellern Europas haben wir eine sehr gute Erfahrung auch in dem Bereich Magazinkassetten entwickelt. Gerne bieten wir Ihnen folgende Ausführungen: für ISO, HSK und alle andere, nach Ihrem Wunsch.

PINCES DE LOGEMENT POUR LE MAGASIN DES MACHINES OUTILS

Grâce a notre constante et intensive collaboration avec les plus célèbres constructeurs des machine outils, nous avons développé une bonne expérience pour la production de pinces des logement pour le magasin des machines outils. Dans notre gamme il y a attachements: ISO, HSK et autres. Naturellement nous sommes ouverts à construire autres types de pinces suite aux differents plans du client.

ЗАХВАТЫ ДЛЯ ИНСТРУМЕНТАЛЬНОГО МАГАЗИНА

Благодаря постоянному и тесному сотрудничеству с самыми известными производителями инструмента мы получили большой опыт в изготовлении высокоточных захватов для инструментальных магазинов. Линейка захватов включает в себя самые часто используемые модели: для конусов ISO и HSK. Разумеется, мы готовы изготовить специальный захват по чертежам заказчика.

刀具库使用的夹具

由于我公司长期与著名的机器工具制造商进行全面的合作，我公司已经积累了制造刀具库使用高精度夹具的丰富经验。我们的产品范围包括最受欢迎的附件夹具：ISO 锥体、HSK，当然，我公司也乐于制造根据客户提供的图纸确定的任何新版本的产品。



CLAMPING FINGERS PINZE PER MAGAZZINI UTENSILI
 GREIFER FÜR WERKZEUGMAGAZIN PINCES DE LOGEMENT POUR LE MAGASIN DES MACHINES OUTILS
 ЗАХВАТЫ 夹具

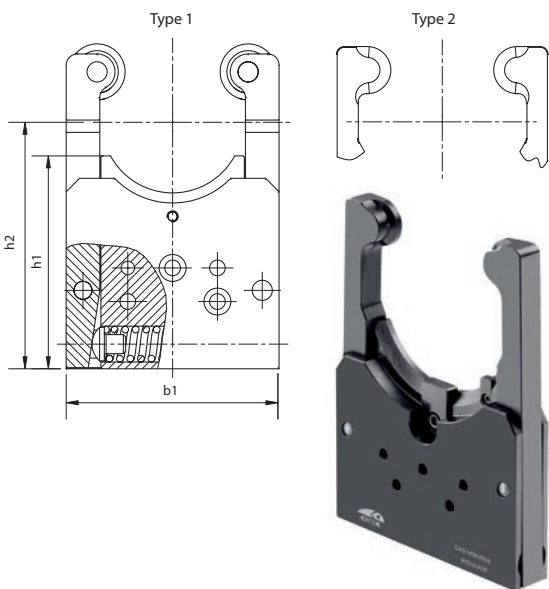

CODE N.	TOOL	b1	h1	h2	TYPE	TYPE SPRING
832-018030	HSK 63A	95	95	110	1	A
832-018470	HSK 63A	95	95	110	1	B
832-018020	HSK 100A	135	118	139	2	A
832-018480	HSK 100A	135	118	139	2	B
832-007940	C63	95	91	110	1	A
832-018490	C63	95	91	110	1	B
832-018050	C80	105	85	110	1	A
832-018500	C80	105	85	110	1	B
832-007980	KM 63	95	100	110	2	A
832-018510	KM 63	95	100	110	2	B
832-018520	TC 40	95	95	110	1	A
832-018530	TC 40	95	95	110	1	B
832-018360	TC 50	135	118	139	2	C
832-018210	TC 50	135	118	139	2	A
832-018540	BT 40	95	95	110	1	A
832-018550	BT 40	95	95	110	1	B
832-018370	BT 50	135	118	139	2	C
832-018200	BT 50	135	118	139	2	A

A Middle Strength Spring

Molla Forza Media
 Mittelkraft Feder
 Ressort moyen force
 Пружина средней жесткости
 中等强度的弹簧

B Stiffened Spring

Molla Rinforzata
 Verstärkte Feder
 Ressort renforcé
 Пружина повышенной жесткости
 强化弹簧

C Normal Spring

Molla Normale
 Normale Feder
 Ressort normal
 Пружина нормальной жесткости
 正常弹簧



HSK ACCESSORIES



ASSEMBLY SUPPORTS SUPPORTO DI MONTAGGIO
MONTAGEBLOCK SUPPORTS D'ASSEMBLAGE
СТОЙКА ДЛЯ СБОРКИ ИНСТРУМЕНТА 组件支架

It is very useful for all assembly and disassembly operations of the tools on the toolholders, either in horizontal or in vertical position. This process is carried out without any risk to damage casually the tool or the toolholder. It is a very simple system suitable for HSK toolholders.

Consente di effettuare tutte le operazioni di montaggio e smontaggio degli utensili sui mandrini, sia in orizzontale che in verticale. Questi procedimenti avvengono con razionalità, sicurezza, rapidità e senza alcun rischio di danneggiare il mandrino o l'utensile. È il sistema che offre la massima semplicità d'uso per i mandrini HSK.

Dieses unkompliziertes System erlaubt die schnelle und sichere Montage und Demontage von Steilkegelaufnahmen in horizontaler und vertikaler Lage. Das Risiko der Werkzeugbeschädigung ist ausgeschlossen. Es eignet sich natürlich auch für modulare HSK-Aufnahmen.

Il permetts d'effectuer toutes les opérations de montage / assemblage / démontage des outils sur les mandrins. Ces proces se déroulent avec rationalité, sûreté, vitesse et sans aucun risque d'endommagement accidentel du mandrin ou de l'outil. C'est un système qui offre la plus haute simplicité d'usage et il est bien indiqué pour les HSK mandrin.

Приспособление очень удобно для операций сборки и демонтажа инструмента, как в вертикальном, так и в горизонтальном положении. Оно позволяет избежать повреждения оправок или режущего инструмента. Это простое приспособление подходит для монолитных оправок.

它对于所有将工具以垂直或水平方向安装在刀柄上和从工具柄上拆除, 均非常有用。这一过程的执行不会对工具或刀柄产生任何破坏的风险。这一非常简单的系统适用于 HSK 刀柄。



HSK	CODE N
A+C 32	237-32150
A+C 40	237-32250
A+C 50	237-32350
A+C 63	237-32450
A+C 100	237-32650
B+D 40	237-32260
B+D 50	237-32360
B+D 63	237-32460
B+D 100	237-32660
E4,F40	237-32270
E50,F50	237-32370
E63,F63	237-32470

ASSEMBLY SUPPORTS ECONOMIC VERSION SUPPORTO DI MONTAGGIO VERSIONE ECONOMICA
MONTAGEBLOCK SUPPORTS D'ASSEMBLAGE
УСТРОЙСТВО ДЛЯ СБОРКИ ИНСТРУМЕНТА. ЭКОНОМИЧНАЯ ВЕРСИЯ. 经济型组件支架

ECONOMIC VERSION



CODE N.	ATTACK
268-30001	HSK 63A-C-D-E
268-30002	HSK 100A-C-D-E

07

COOLANT SUPPLY UNIT SET ADDUZIONE REFRIGERANTE
KÜHLMITTELÜBERGABEROHR DISPOSITIF DE TRANSFERT DE LIQUIDE DE LUBRIFICATION
СОПЛА ДЛЯ ВНУТРЕННЕЙ ПОДАЧИ СОЖ 冷却剂供应装置

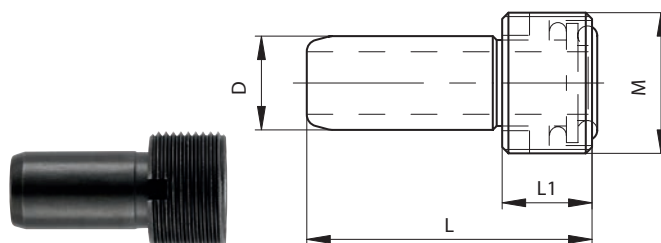

HSK	CODE N.	M	D	L	L1
A+C32,B+D40	832-016010	M10x1	6	26	5.5
A+C40,B+D50,E40,F50	832-016020	M12x1	8	29.3	7.5
A+C50,B+D63,E50,F63	832-016030	M16x1	10	33	9.5
A+C63,E63	832-016040	M18x1	12	36.6	11.5
B+D100-80A	832-016050	M20x1.5	14	40	13.5
A+C100	832-016060	M24x1.5	16	44	15.5

KEY FOR COOLANT SUPPLY UNIT CHIAVE PER ADDUTTORE REFRIGERANTE
SCHLÜSSEL FÜR KÜHLMITTELÜBERGABESATZ CLE POUR LE DISPOSITIF DE TRANSFERT DE LIQUIDE DE LUBRIFICATION
КЛЮЧИ К СОПЛАМ ДЛЯ ВНУТРЕННЕЙ ПОДАЧИ СОЖ 冷却剂供应装置键

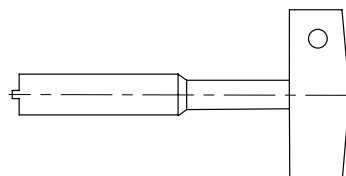

HSK	CODE N.
40	816-204022
63	816-204024
100	816-204025