

PRECISION INDEXING

INDEXERS, CONVEYORS & PART HANDLERS

destaco.com

PRODUCT OVERVIEW

MARKETS



AEROSPACE



INDUSTRIAL



CONSUMER GOODS



FOOD & PACKAGING



LIFE SCIENCES



TRANSPORTATION

ABOUT DESTACO

Built on a Strong Foundation

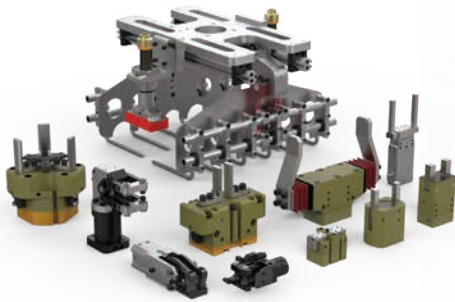

Gripping Solutions

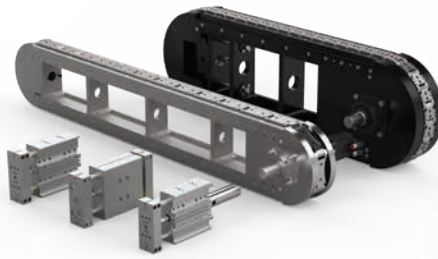

Linear Positioning Solutions

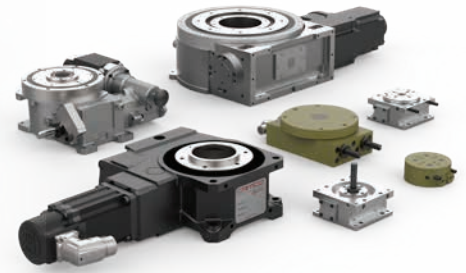

Rotary Positioning Solutions



Clamping Solutions



CRL Remote Handling Solutions



Robotic Tooling Solutions

DESTACO, a Stabilus Group company, is a global leader in the design and manufacture of high-performance automation, workholding and remote-handling solutions. The company serves customers in a variety of end-markets, including the automotive, life sciences, consumer packaged goods, aerospace, industrial and nuclear sectors.

Built on a legacy of more than 100 years, DESTACO offers a comprehensive portfolio of products designed to engineer precise movement, placement and control solutions that drive productivity and uptime for manufacturers around the world. The DESTACO family of products consists of industry-leading brands such as DESTACO Manual Clamps, Power Clamps, and End Effectors; CAMCO™ and Ferguson™ Indexers; Robohand™ Grippers; and CRL™ Manipulators and Transfer Ports.

DESTACO is based in Auburn Hills, Michigan, U.S.A. The company has more than 800 employees with 13 locations, in 9 countries, across the Americas, Europe and Asia.

The Stabilus Group is one of the world's leading providers of motion control solutions for customers across a broad spectrum of industries including mobility, health, recreation, furniture, energy, construction, industrial machinery and automation. With more than eight decades of demonstrated expertise, Stabilus offers reliable and innovative motion control solutions that enable, enhance and automate opening, closing, lifting, lowering and adjusting actions. The company's customized damping and vibration isolation technology protects against shocks, vibrations and noise. Employing a workforce of more than 7,000 worldwide, the company has its operational headquarters in Koblenz, Germany. In the 2024 fiscal year Stabilus has reported revenues of EUR 1.3 billion. Stabilus has a global production network encompassing plants in nine countries. Additionally, the Group maintains regional offices and relations to sales partners in over fifty countries in Europe, North and South America, as well as in Asia-Pacific. Stabilus SE is listed in the Prime Standard segment of the Frankfurt Stock Exchange and included in the MDAX index.

More information is available at destaco.com and www.stabilus.com

Focusing all of our Resources

New Product Development

DESTACO has dedicated resources to design and build the next generation of products and solutions

Customer Service and Technical Support

DESTACO has industry leading global support to address any product and application concerns you may have

Design Tools

DESTACO provides an extensive CAD library, sizing software, and online tools to support our global customers



Our Insight Working for You

Application Engineering

We utilize our expertise and complete portfolio of products to create solutions that fit our customers' needs and applications

Custom Solutions

If our off-the-shelf solutions don't fit, we will partner with our customers to develop products that will



Rotary Indexers and Conveyor Solutions

Smarter Precision Indexing

DESTACO's Camco products have been the industry standard for the highest quality cam-actuated motion control products available DESTACO manufactures a wide range of motion control products including indexing drives, linear and rotary parts handlers, precision link conveyors, magnetically-propelled conveyors, servo-mechanical drives, and custom cams.

CLICK OR SCAN
QR code for full catalog pages on these products

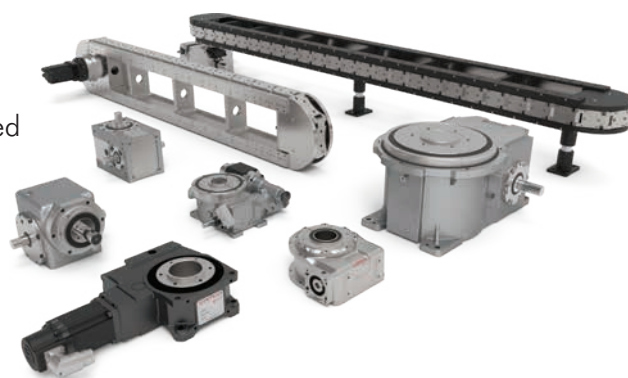

Markets



Applications



RDM Series

Low Profile Roller Dial Index Drives

- Large center through-hole for air, electric and hydraulic utilities
- Superior thrust and moment capacity due to large output mounting surface that is supported by a 4-point contact bearing
- Variety of drive packages with optional overload clutch feature

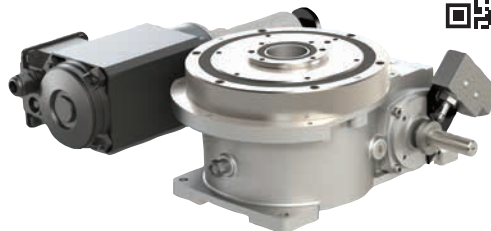

RD Series

Roller Dial High-Load Index Drives

- Well suited for continuous running operations via short camshaft motion periods and special motion requirements.
- Universal mounting supports horizontal and trunnion mount applications
- Center through-hole for air, electric, hydraulic and mechanical linkages utilities
- Customized motions available including oscillating motions



Parallel Index Drives

High Speed and High Load Capability Solutions

- Ideal for high speed conveying or driving mechanical linkage applications
- Backlash-free rigid operation
- Provides Long transfer distances with simple linkages
- Whole or fractional stops, oscillating and complex custom motions available

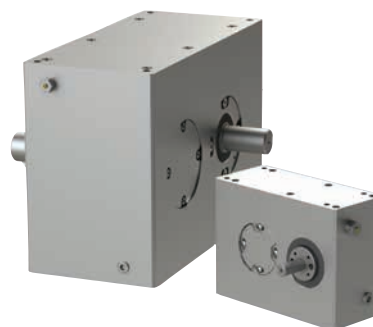

RGD/RGS Series

Roller Gear Index Drives

- Robust flexible unit supporting a wide variety of industrial applications
- Universal mounting includes mounting holes on all six sides
- Customized motions available including oscillating motions or short index periods



RA Series

Roller Dial High-Load Index Drives

- Well suited for continuous running operations via short camshaft motion periods and special motion requirements.
- Universal mounting supports horizontal and trunnion mount applications
- Center through-hole for air, electric, hydraulic and mechanical linkages utilities
- Customized motions available including oscillating motions



CLICK OR SCAN

QR codes for full catalog pages on products

GTB Series

Servo Positioners

- High payload compact size indexing solutions
- Freely programmable servo reducer indexers
- Zero maintenance lubricated for life
- Supports both horizontal and vertical mounting
- Compatible with multiple brands of servo motors



RSD Series

Zero-backlash Flexible Rotary Servo Drive Solutions

- Cam-actuated drive servo driven for precise control
- Preloaded for zero backlash, high accuracy, and smooth motion
- 4:1 to 18:1 ratio in single state
- Compatible with variety of industry-standard servo motors



RNG Ring Index Drives

Automatic Assembly Machinery Application Solution

- Ideal for pad printing, decorating equipment and applications requiring up to 60 workstations with minimal floor space.
- Easy serviceability access and mounting auxiliary equipment
- Superior accuracy and load capability using sealed 4-point contact output bearing
- Application flexibility and easy maintenance with modular shaft-mounted reducers

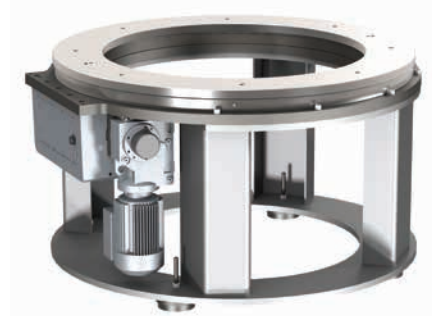

E-Series

Heavy-Duty Large Moment Index Drives

- Ideal for Automotive and other applications requiring high precision index positioning
- Superior thrust and moment capacity due to large output mounting surface that is supported by a 4-point contact bearing
- Delivers smooth acceleration and deceleration using a preloaded "center rib" design

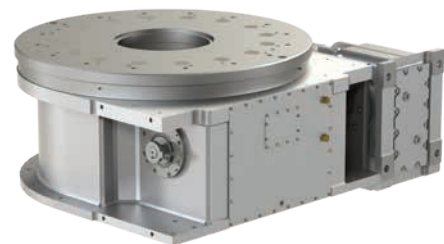

Rite-Link Series

Thin Profile Pre-assembled Conveyor

- Maintenance free accuracy and durability industrial conveying applications
- Faster and more accurate precision link system over roller chain conveyors
- Oversized tooling supported in a slim, compact conveyor design
- Designed to your specifications, fully assembled and tested by DESTACO



Precision Link Conveyor

Multiple-Station Chassis Table Top Solutions

- Ideal for modular assembly of complicated products requiring precision positioning of parts.
- Open frame design supports pass through of belting, linkages, electric or air supply components
- 3 to 40 feet Conveyor lengths with link pitch of 3, 4.5, and 6 inches
- Quick assembly and delivery using a modular 18" increment frame design

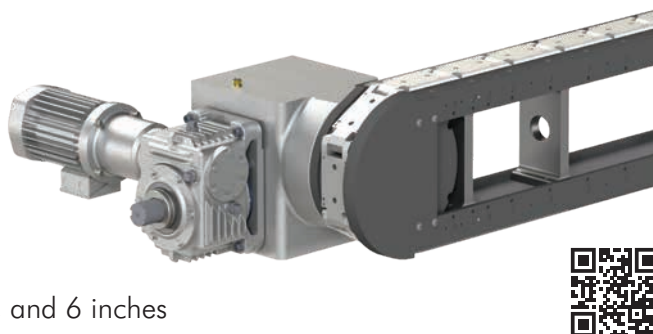

Heavy Duty Precision Link Conveyors

Modular, Accurate with High-Load Capacity

- Maintenance free accuracy and durability industrial conveying applications
- Faster and more accurate precision link system over roller chain conveyors
- Oversized tooling supported in a slim, compact design
- Designed to your specifications, fully assembled and tested



LPP Series

Linear Parts Handler

- Cost effective design for low-cost operation
 - Reliable Camco mechanical cam design
 - Lubed for Life
- Easy integration with other DESTACO products for one-stop shopping
- Input shaft available on either side for ease of integration
- Line shaft drive or gear reducer and motor drive package for synchronous or asynchronous operation
- Standard or custom strokes and timing designed for your specific requirements



RPP Series

Rotary Parts Handler

- Rugged and precise cam operated mechanisms engineered for a minimum of 8000 hours of maintenance-free life.
- Hardened and ground cams drive both the lift and rotary axes
- Preloaded precision cam followers eliminate backlash and ensure smooth movement
- Preloaded taper roller bearings on the camshaft (Input Shaft)
- Four-point contact preloaded roller bearing on the rotary axis
- All bearings are lubricated by an oil bath
- One-piece lift arm



Overload Clutches

Output Overload Protection

- Easily mounts to Camco Index Drives
- Single position reset to maintain accuracy and machine timing
- Precision hardened and ground plungers and drive plate
- Overload detector plate provides actuation for overload detector switch
- Variety of models for all applications
- Standard & custom torque settings



Custom Cams

Design and Manufacturing Services

- Backed by 100 years of experience
- Comprehensive range of configurations, tolerances and materials
- Precise, economical and engineered for your exacting specifications
- Alternative to "in-house" design, engineering and manufacturing



Fixed and Flexible Dials, Conveyors and Parts Handlers

Cycle on Demand Indexer with Fixed Number of Stations

- RDM indexer with user controlled variable dwell time
- Single index cycle with user controlled variable dwell time
- Index time is controlled by varying frequency setting of inverter drive
- 60 or 30 indexing cycles per minute using an AC or DC motor and drive respectively

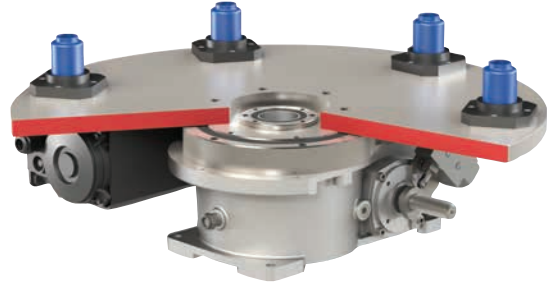

Servo Driven Indexer with Variable Number of Stations

- 115RSD indexer with user controlled variable dwell time
- Single index cycle with user controlled variable dwell time
- Index time is controlled by varying motion profile of servo motor
- Supports single-axis and multi-axis servo controllers
- Exceeds 60 indexing cycles per minute



Conveyor and Linear Part Handlers Controlled by Indexer

- Integrated solutions center using indexer, conveyor and part handlers
- User controlled variable dwell time by varying motion profile of servo motor
- Supports single-axis and multi-axis servo controllers
- Exceeds 60 indexing cycles per minute

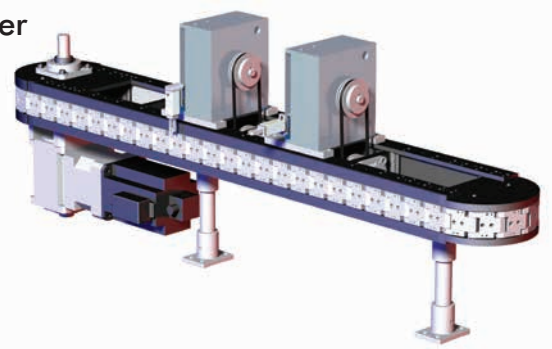

Pick and Place or Load and Unload with Grippers

- Integrated solutions using Robohand Grippers, Rotaries and Cambot LPP Part handlers
- Create customized rotary pick and place application solutions
- PLC Sequencing logic used for Motion axis and gripper action



Flexible Multi-Axis and High Speed

Cambot Flexible Pick and Place Solutions

- Servo driven indexer supporting high moment capacity payloads
- Large output flange for mounting a custom end-effector solution
- Integrate DESTACO's versatile grippers, slides and vacuum products for pick and place actuation

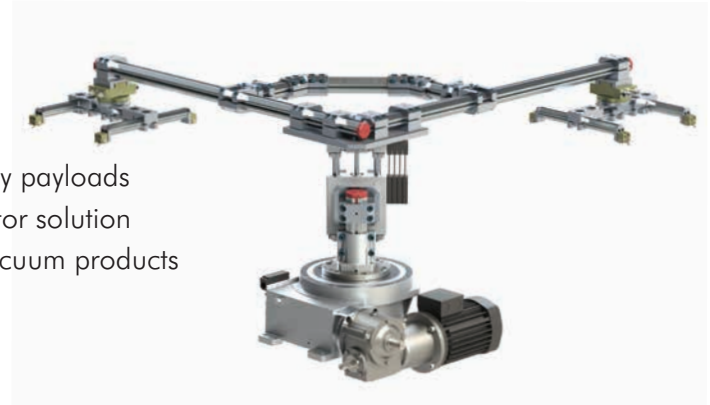

Tube Cutting Variable Length Flying Cutoff

- Cut to Length formed tube using coupled CAMCO Roller Gear models
- Servo motor drives both gear boxes and maintains synchronization with speed variations of tube line.
- Indexer (A) moves the cutting tool into the correct position adapting to line speed variations
- The Oscillator (B) moves the cutting tool up and down
- Tube length is controlled by increasing arm length (A) or allowing the tube to flow out before cycling servo motor

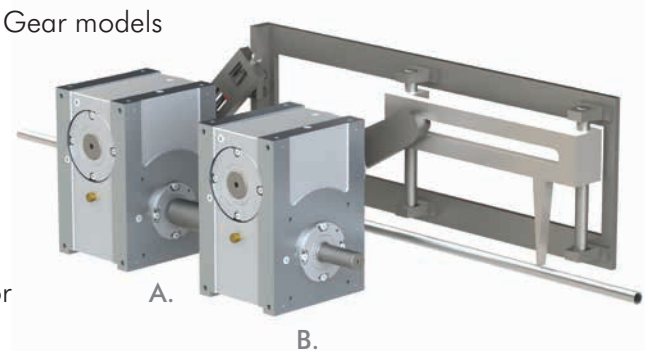

Paper or Plastic Web High Speed Contouring Application

- Processes 1000 Parts per minute For high speed contouring
- Uses two lasers cutting tools mounted to the oscillating arms
- Customized to customers application pattern
- DESTACO designed custom cams to meet the application specifications
- Produces a dynamically stable cam solution requiring no maintenance
- Servos are linked to the web line keeping it in sync for the application

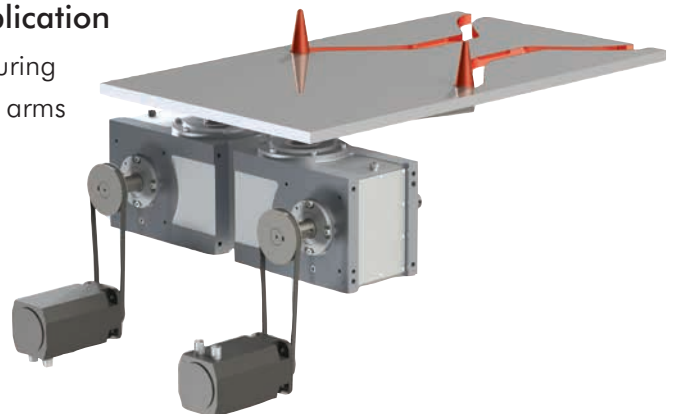

Large Moment Capacity Rotary Motion Application

- Heavy-Duty E-Series Index Drive with large center utility thru-hole to accommodate electrical, air and hydraulic lines
- Delivers high precision index positioning with smooth acceleration and deceleration
- Superior thrust and moment capacity due to large output mounting surface, supported by a 4-point contact bearing

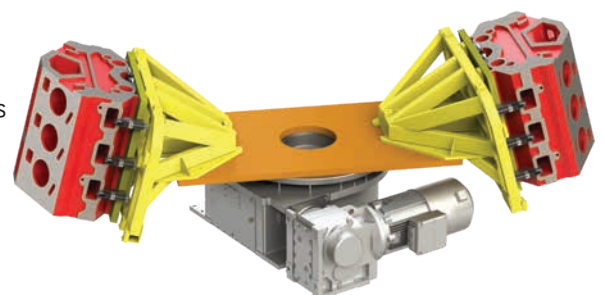

COMPLETE HIGH SPEED PRECISION SOLUTIONS

DESTACO with Camco and Robohand products offer complete standard and custom automation solutions for high speed, precision indexing and pick-and-place applications.

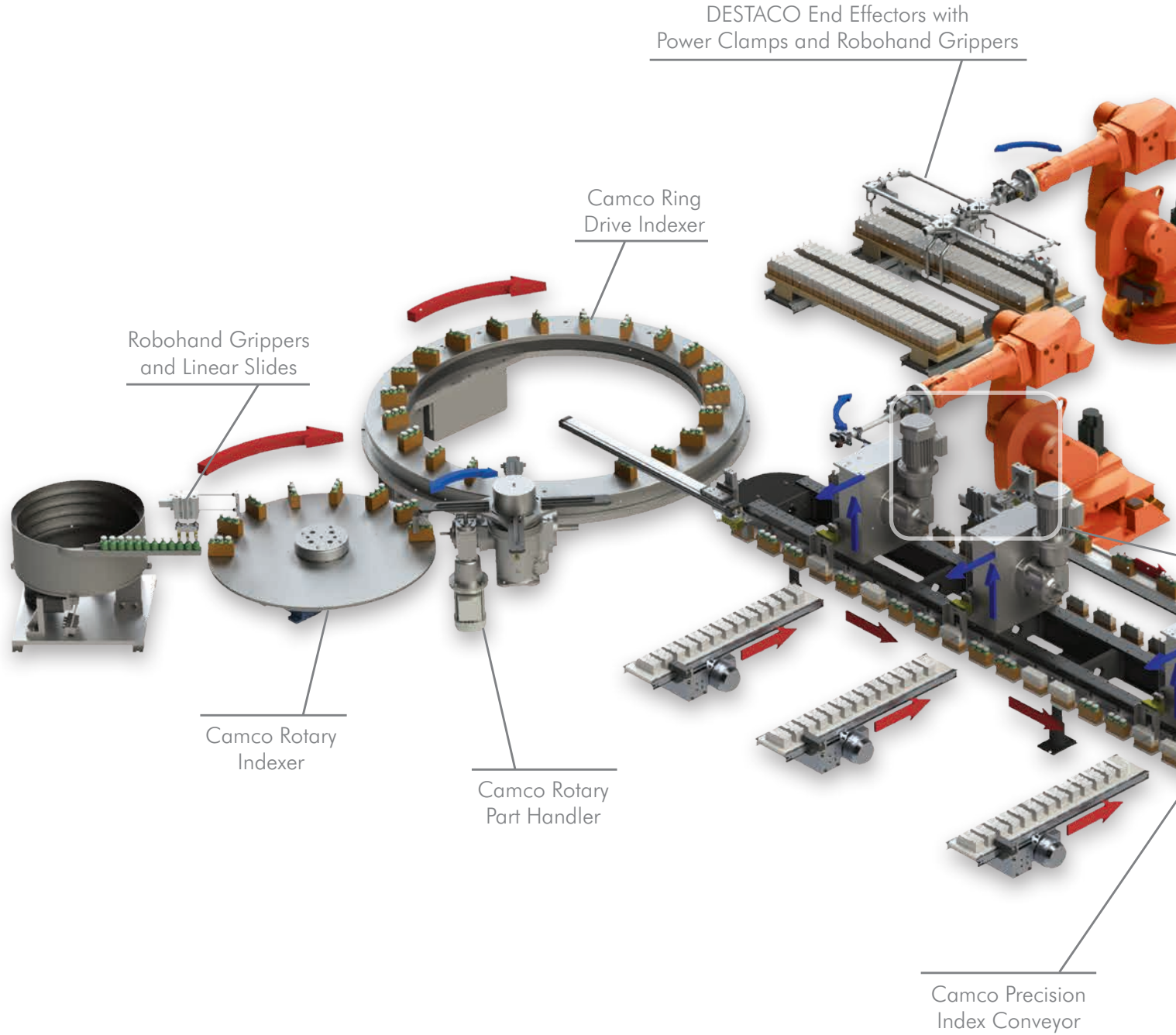

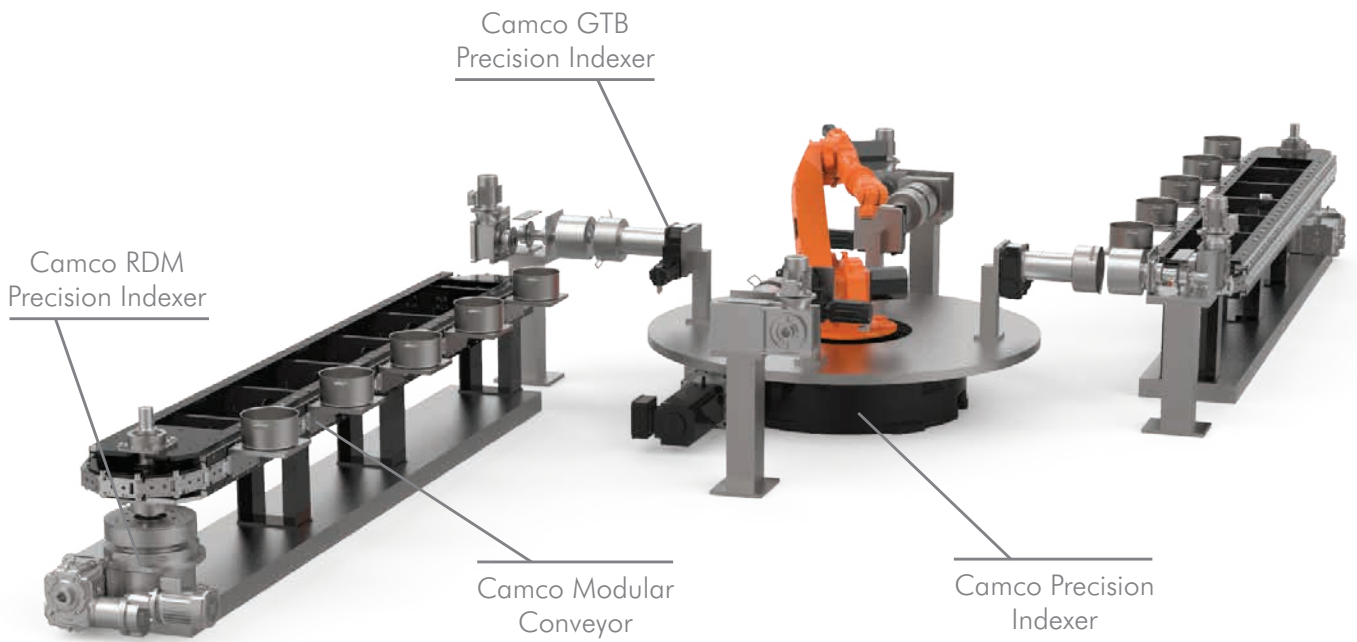

Camco LPP Linear Parts Handler with Robohand Grippers

DESTACO End Effector with Vacuum Products

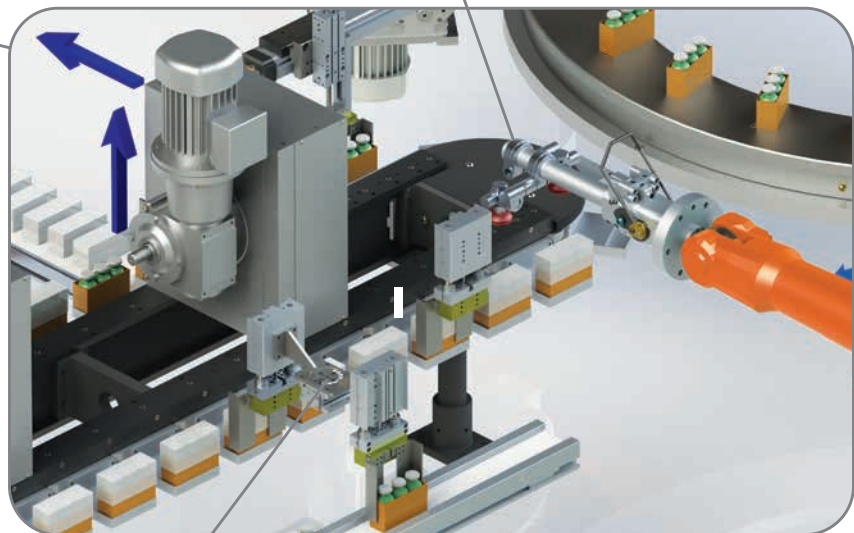
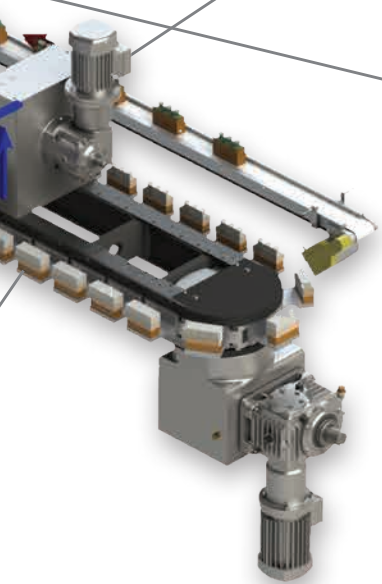

Robohand Rotaries, Slides and Grippers

GLOBAL SALES CONTACTS

CORPORATE HEADQUARTERS

 **US**
+1-888-DESTACO
+1-248-836-6700
northamerica@destaco.com

THE BEST PRODUCTS.
UNMATCHED SERVICE.
WORLDWIDE.

 **DE**
+49-6171-705-0
europe@destaco.com

 **SP**
+34-936361680
spain@destaco.com

 **PL**
+48-506002115
poland@destaco.com

 **IN**
+91-80-41123421-426
india@destaco.com

 **MX**
mexico@destaco.com

 **FR**
+33-4-7354-5001
france@destaco.com

 **CN**
+86-21-2411-2678
china@destaco.com

 **NL**
+31-297285332
benelux@destaco.com

 **SG**
singapore@destaco.com

 **UK**
+44-1902-797980
uk@destaco.com

 **TH**
+66-2326-0812-6
asia@destaco.com

 **CZ**
+420-603-577-341
czech@destaco.com

 **CA**
canada@destaco.com



Click or Scan for
the latest PDF version
of this document.



Click or Scan
to learn more
about Stabilus.



Industries

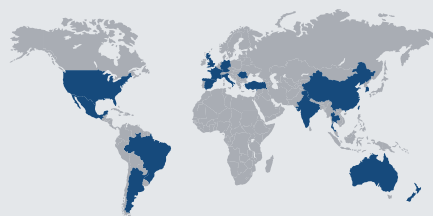

45 Locations in 19 Countries



8K Employees



2023 Revenues

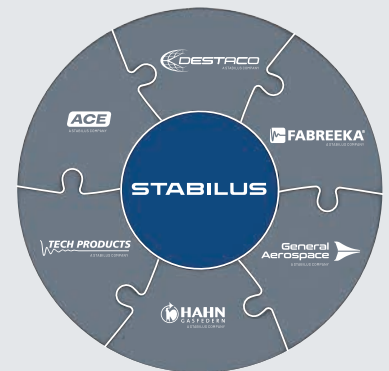

Expert Brands