

# 2002 SERIES

## Vertical Hold Down Clamps | Product Overview

### Features:

- Large hand clearance for improved safety
- Bolt pattern interchangeable with 202 Series
- Three times the holding capacity of 202 Series
- Hardened bushings at key pivot points
- Near vertical clamping contact
- BLK models feature a black, non-reflective finish
- 5 handle colors - see page MC-PRO-7 for details

Covered under one or more U.S./International Patents

### Applications:

- Checking fixtures
- Assembly & test
- Light machining
- Woodworking

### Also Available:

See page MC-ACC-1 for accessories  
Accepts M6 or 1/4 spindle accessories

**2002-U/USS**  
Flanged Base  
U-Bar



-USS Stainless  
Steel Model



**2002-U-LS-BLK** ⓘ  
Blackout Series  
Flanged Base  
U-Bar



**2002-S**  
Flanged Base  
Solid Bar



**2002-UB**  
Straight Base  
U-Bar



**2002-UB-LS-BLK** ⓘ  
Blackout Series  
Straight Base  
U-Bar



**2002-SB**  
Straight Base  
Solid Bar



**2002-UR/URSS**  
Flanged Base  
U-Bar  
DESTACO®  
Toggle Lock Plus



-URSS Stainless  
Steel Model



**2002-SR** ⓘ  
Flanged Base  
Solid Bar  
DESTACO®  
Toggle Lock  
Plus



**2002-UBR**  
Straight Base  
U-Bar  
DESTACO®  
Toggle Lock  
Plus



**2002-SBR** ⓘ  
Straight Base  
Solid Bar  
DESTACO®  
Toggle Lock  
Plus



**2002-U207**  
Flanged Base  
U-Bar

Interchangeable  
with 207 Series



**2002-UR207**  
Flanged Base  
U-Bar

Interchangeable  
with 207 Series  
DESTACO®  
Toggle Lock  
Plus



**2002-UF**  
Front Mount Base  
U-Bar



### Color Handles

Available on models  
in this series that use  
standard red handles.\*  
Add -Y, -G, -B, -K to  
end of model number.

\*Excludes Blackout Series,  
Toggle Lock Plus levers  
or dipped handles.



ⓘ This item is available upon request

# 2002 SERIES

## Vertical Hold Down Clamps | Technical Information

Model	Max. Holding Capacity	Clamp Bar Opening(+10°)	Handle Opening (+10°)	Weight	Accessories (Supplied)				
					Bolt Retainer	Spindle Assembly	Flanged Washers		
2002-U	[600 lbf] 2700 N	75°	66°	[0.48 lbs] 0,22 kg	--	215208-M	215105		
2002-USS					--	202943-M	215905		
2002-U-LS-BLK ⓘ					--	--	215105-BLK		
2002-S					2002115-E	--	--		
2002-UB					--	215208-M	215105		
2002-UB-LS-BLK ⓘ					--	--	215105-BLK		
2002-SB					2002115-E	--	--		
2002-UR				--	215208-M	215105			
2002-URSS				--	202943-M	215905			
2002-SR ⓘ				2002115-E	--	--			
2002-UBR				--	215208-M	215105			
2002-SBR ⓘ				2002115-E	--	--			
2002-U207				90°	72°	[0.57 lbs] 0,26 kg	--	215208-M	215105
2002-UR207				75°	57°				

ⓘ This item is available upon request

## Holding Capacities

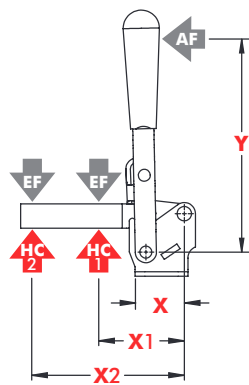

Model	X	X1	X2	Y	±HC1	±HC2	±EF(X1):AF	±EF(X2):AF
2002-( )	[1.12] 28,5	[1.45] 37	[2.64] 67	[3.66] 93	[600 lbf] 2700 N	[295 lbf] 1310 N	11:1	5:1

Dimensions shown "mm [inch]" ± HC = Holding Capacity, EF = Exerting Force, AF = Applied Force  
See page MC-TEC-4 for additional information.

# 2002 SERIES

Vertical Hold Down Clamps | Dimensions | -U/-S/-UB/-SB/-UR/-SR/-UBR/-SBR

**2002-U**  
Flanged Base  
U-Bar

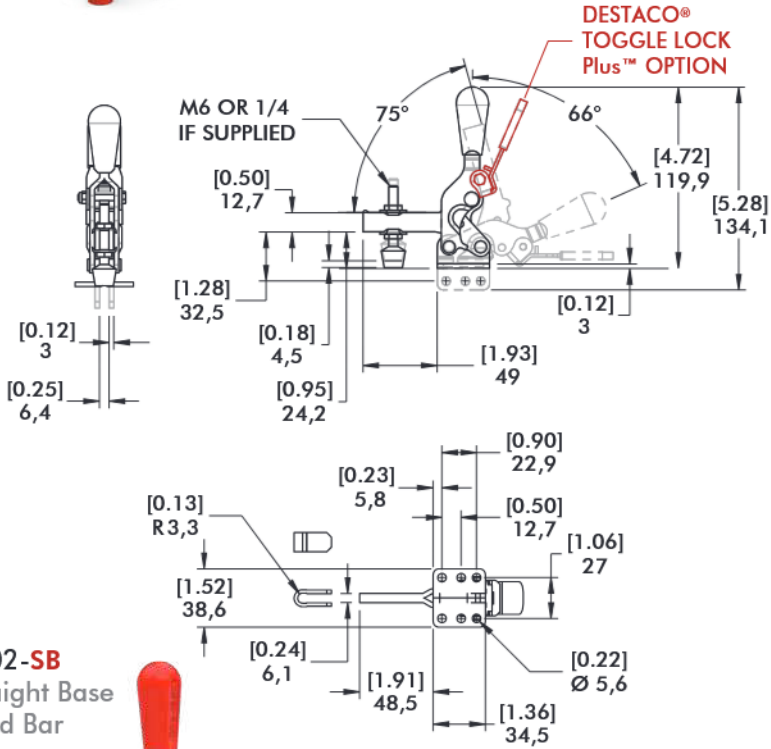
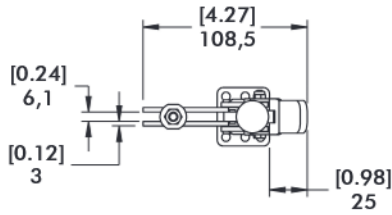

**2002-SB**  
Straight Base  
Solid Bar



**2002-U207/2002-UR207**  
with interchangeable Series 207  
Mounting Pattern

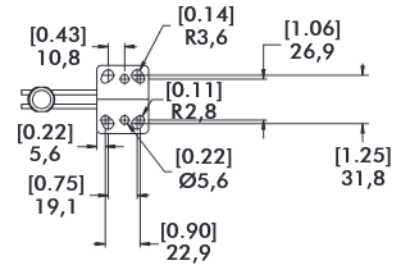
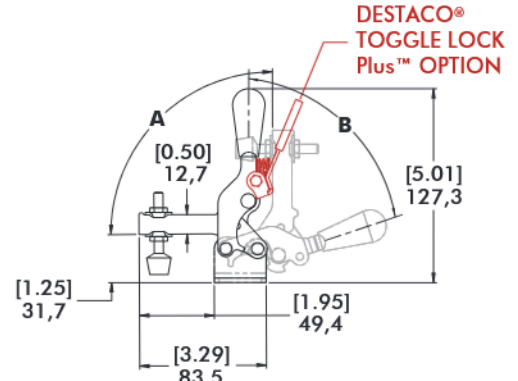
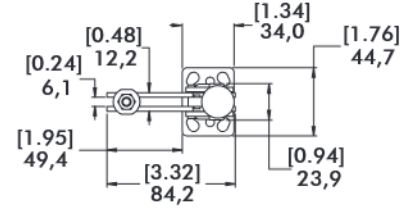

Model	A	B
2002-U-207	90°	72°
2002-UR207	75°	57°

**2002-UF**  
 Flanged Base  
 U-Bar  
 DESTACO®  
 Toggle Lock  
 Plus

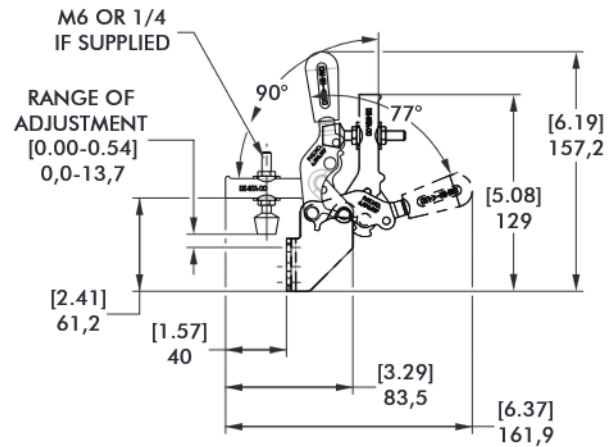
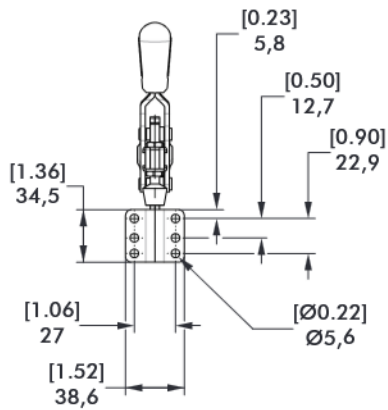
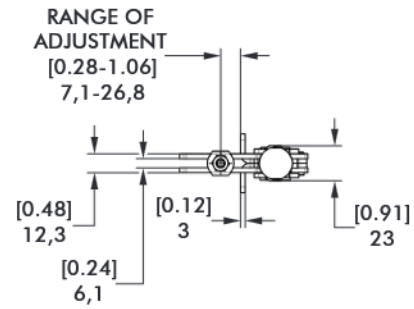

# 2007 SERIES

## Vertical Hold Down Clamps | Product Overview

### Features:

- Large hand clearance for improved safety
- Bolt pattern interchangeable with 207 Series
- Over two times the holding capacity of 207 Series
- Hardened bushings at key pivot points
- Near vertical clamping contact
- 5 handle colors - see page MC-PRO-7 for details

Covered under one or more U.S./International Patents

### Applications:

- Checking fixtures
- Assembly & test
- Light machining
- Woodworking

### Also Available:

See page MC-ACC-1 for accessories  
Accepts M8 or 5/16 spindle accessories

**2007-U/USS**  
Flanged Base  
U-Bar



-USS Stainless  
Steel Model



**2007-U-LS-BLK** ⓘ  
Blackout Series  
Flanged Base  
U-Bar



**2007-S**  
Flanged Base  
Solid Bar



**2007-UB**  
Straight Base  
U-Bar



**2007-UB-LS-BLK** ⓘ  
Blackout Series  
Straight Base  
U-Bar



**2007-SB**  
Straight Base  
Solid Bar



**2007-UR/URSS**  
Flanged Base  
U-Bar  
DESTACO®  
Toggle Lock Plus



-URSS Stainless  
Steel Model



**2007-SR** ⓘ  
Flanged Base  
Solid Bar  
DESTACO®  
Toggle Lock Plus



**2007-UBR**  
Straight Base  
U-Bar  
DESTACO®  
Toggle Lock Plus



**2007-SBR** ⓘ  
Straight Base  
Solid Bar  
DESTACO®  
Toggle Lock Plus



**2007-UF**  
Front Mount Base  
U-Bar



**Color Handles**  
Available on models  
in this series that use  
standard red handles.\*  
Add -Y, -G, -B, -K  
to end of model number.

\*Excludes Blackout Series,  
Toggle Lock Plus levers  
or dipped handles.



# 2007 SERIES

## Vertical Hold Down Clamps | Technical Information

Model	Max. Holding Capacity	Clamp Bar Opening (+10°)	Handle Opening (+10°)	Weight	Accessories (Supplied)		
					Bolt Retainer	Spindle Assembly	Flanged Washers
2007-U	[1000 lbf] 4450 N	76°	64°	[1.20 lbs] 0,54 kg	--	2007208-M	507107
2007-USS					--	207943-M	507907
2007-U-LS-BLK ⓘ					--	--	507107-BLK
2007-S					2007115-E	--	--
2007-UB					--	2007208-M	507107
2007-UB-LS-BLK ⓘ					--	--	507107-BLK
2007-SB					2007115-E	--	--
2007-UR					--	2007208-M	507107
2007-URSS					--	207943-M	507907
2007-SR ⓘ					2007115-E	--	--
2007-UBR					--	2007208-M	507107
2007-SBR ⓘ					2007115-E	--	--
2007-UF					[1.57 lbs] 0,71 kg	--	2007208-M

ⓘ This item is available upon request

### Holding Capacities

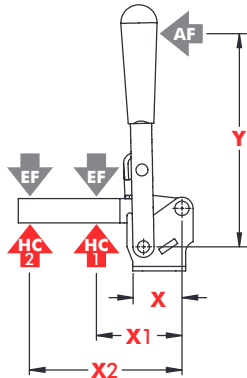

Model	X	X1	X2	Y	±HC1	±HC2	±EF(X1):AF	±EF(X2):AF
2007-( )	[1.59] 40,5	[1.95] 49,5	[3.92] 99,5	[5.16] 131	[1000 lbf] 4450 N	[470 lbf] 2090 N	10:1	5.3:1

Dimensions shown "mm [inch]" ± HC = Holding Capacity, EF = Exerting Force, AF = Applied Force  
See page MC-TEC-4 for additional information.

# 2007 SERIES

Vertical Hold Down Clamps | Dimensions | -U/-USS/-S/-UB/-SB/-UR/-URSS/-SR/-UBR/-SBR

**2007-U**  
Flanged Base  
U-Bar

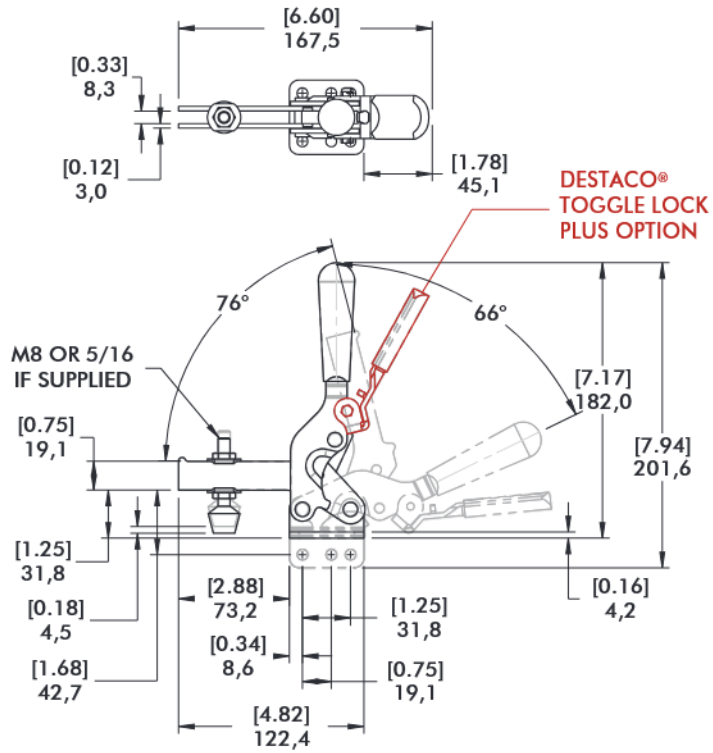
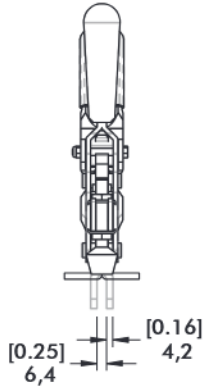

**2007-SB**  
Straight Base  
Solid Bar

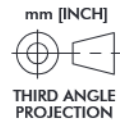
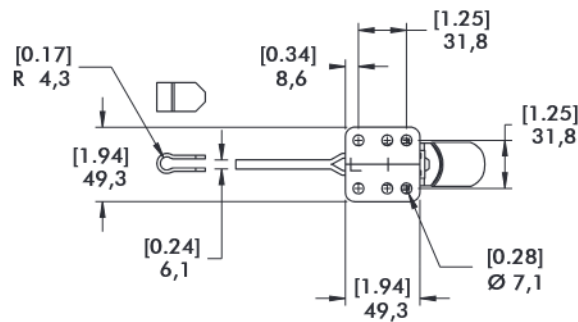

# 2007 SERIES

## Vertical Hold Down Clamps | Dimensions | -UF

2007-UF  
 Flanged Base  
 U-Bar  
 DESTACO®  
 Toggle Lock  
 Plus

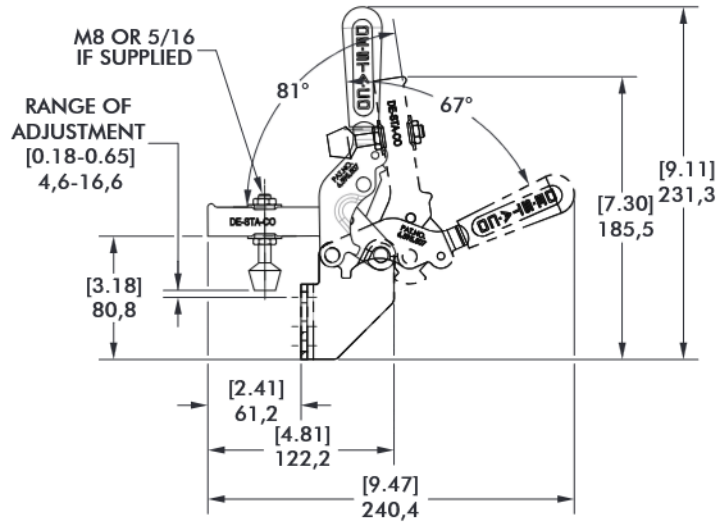
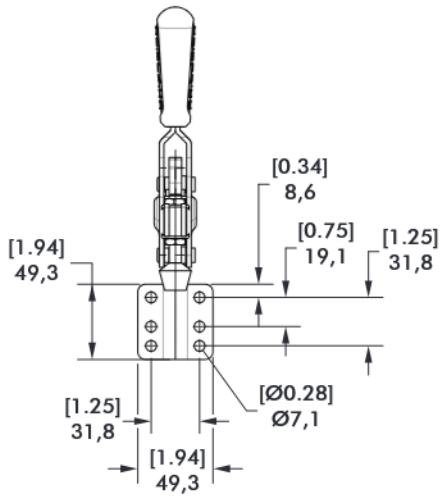
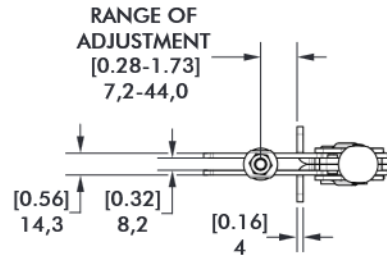



# 2010 SERIES

## Vertical Hold Down Clamps | Product Overview

### Features:

- Large hand clearance for improved safety
- Bolt pattern interchangeable with 210 Series
- Over two times the holding capacity of 210 Series
- Hardened bushings at key pivot points
- Near vertical clamping contact
- 5 handle colors - see page MC-PRO-7 for details

### Applications:

- Checking fixtures
- Assembly & test
- Light machining
- Woodworking

### Also Available:

See page MC-ACC-1 for accessories  
Accepts M10 or 3/8 spindle accessories

Covered under one or more U.S./International Patents

**2010-U**  
Flanged Base  
U-Bar



**2010-S**  
Flanged Base  
Solid Bar



**2010-UB**  
Straight Base  
U-Bar



**2010-SB**  
Straight Base  
Solid Bar



**2010-UR**  
Flanged Base  
U-Bar  
DESTACO®  
Toggle Lock  
Plus



**2010-SR<sup>①</sup>**  
Flanged Base  
Solid Bar  
DESTACO®  
Toggle Lock  
Plus



**2010-UBR**  
Straight Base  
U-Bar  
DESTACO®  
Toggle Lock  
Plus



**2010-SBR<sup>①</sup>**  
Straight Base  
Solid Bar  
DESTACO®  
Toggle Lock  
Plus



**Color Handles**  
Available on models  
in this series that use  
standard red handles.\*  
Add -Y, -G, -B, -K to  
end of model number.



\*Excludes Blackout Series,  
Toggle Lock Plus levers  
or dipped handles.

## Technical Information

Model	Max. Holding Capacity	Clamp Bar Opening (+10°)	Handle Opening (+10°)	Weight	Accessories (Supplied)		
					Bolt Retainer	Spindle Assembly	Flanged Washers
2010-U	[1400 lbf] 6230 N	78°	66°	[2.56 lbs] 1,16 kg	---	240208-M	235106
2010-S					2010115-E	---	
2010-UB					---	240208-M	235106
2010-SB					2010115-E	---	
2010-UR					---	240208-M	235106
2010-SR <sup>①</sup>					2010115-E	---	
2010-UBR					---	240208-M	235106
2010-SBR <sup>①</sup>					2010115-E	---	

<sup>①</sup> This item is available upon request

# 2010 SERIES

## Vertical Hold Down Clamps | Holding Capacities

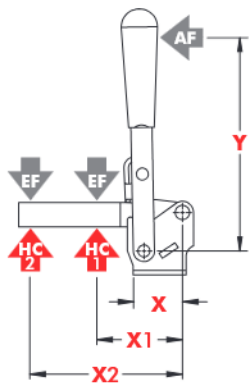

Model	X	X1	X2	Y	±HC1	±HC2	±EF(X1):AF	±EF(X2):AF
2010-( )	[2.04] 51,8	[2.44] 62	[4.88] 124	[7.00] 178	[1400 lbf] 6230 N	[720 lbf] 3200 N	13:1	6:1

Dimensions shown "mm [inch]" ± HC = Holding Capacity, EF = Exerting Force, AF = Applied Force  
See page MC-TEC-4 for additional information.

## Dimensions | -U/-S/-UB/-SB/-UR/-SR/-UBR/-SBR

**2010-U**  
Flanged Base  
U-Bar

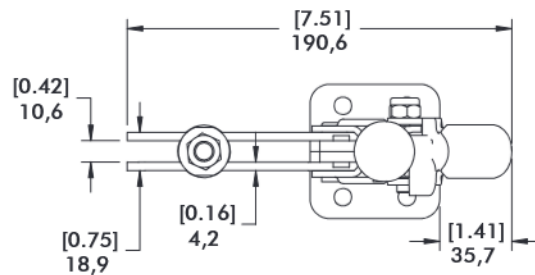

DESTACO®  
TOGGLE LOCK  
Plus™ OPTION

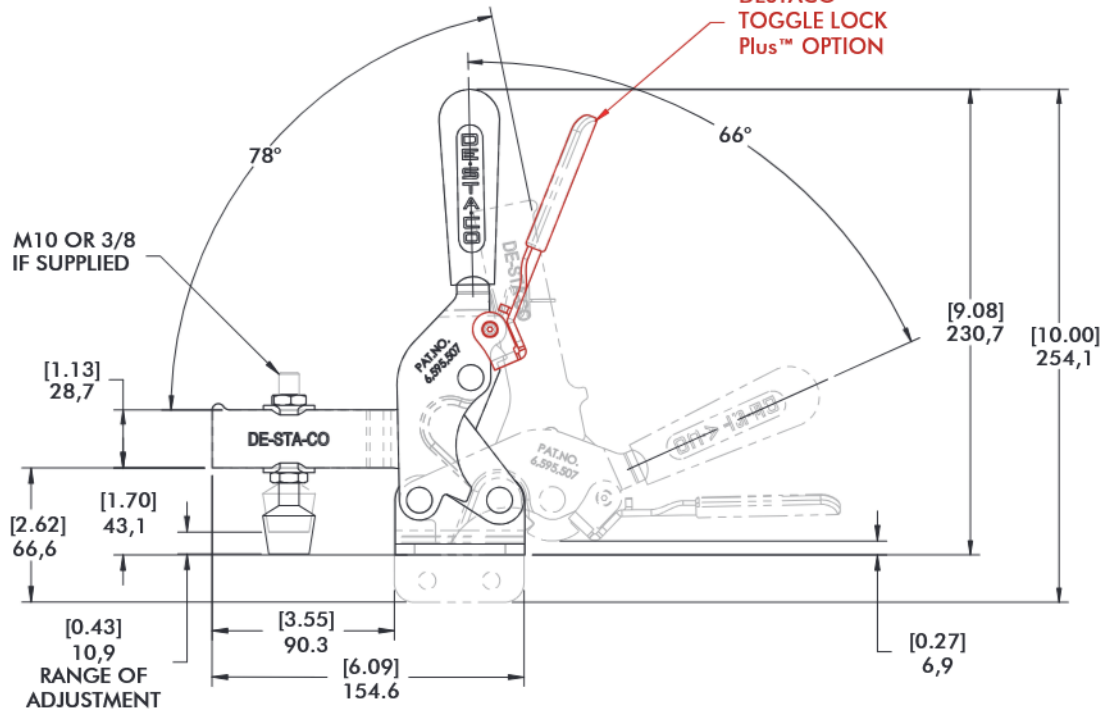

**2010-SB**  
Straight Base  
Solid Bar

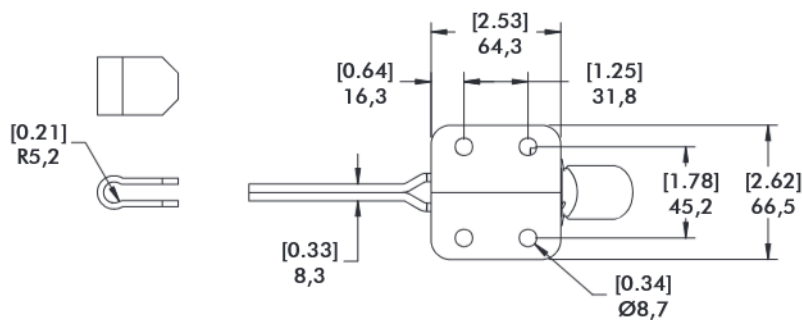

mm [INCH]  
THIRD ANGLE  
PROJECTION

# 201 SERIES

## Vertical Hold Down Clamps | Product Overview

### Features:

- Smallest series in the Vertical Handle series
- Stainless steel version available
- 5 handle colors - see page MC-PRO-7 for details

### Applications:

- Checking fixtures
- Assembly & test
- Woodworking

### Also Available:

See page MC-ACC-1 for accessories

812-U Pneumatic Toggle Clamp  
(See page MC-PTC-1)

### 201-U/USS Flanged Base U-Bar



-USS Stainless Steel Model



### 201-UB Straight Base



### 201-TU Flanged Base U-Bar T-Handle



### Color Handles

Available on models in this series that use standard red handles.\* Add -Y, -G, -B, -K to end of model number.

\*Excludes Blackout Series, Toggle Lock Plus levers or dipped handles.



## Technical Information

Model	Max. Holding Capacity	Clamp Bar Opening (+10°)	Handle Opening (+10°)	Weight	Accessories (Supplied)	
					Spindle Assembly	Flanged Washers
201-U	[100 lbf] 440 N	100°	55°	[0.15 lbs] 0,70 kg	305208-M	102111
201-UB						
201-TU	560 N [125 lbf]				201943-M	102911
201-USS						

## Holding Capacities

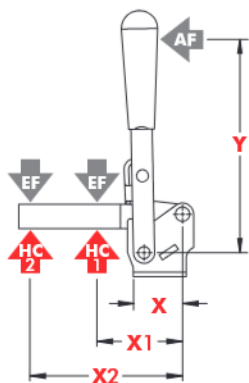

Model	X	X1	X2	Y	±HC1	±HC2	±EF(X1):AF	±EF(X2):AF
U/UB				[2.25] 57	[100 lbf] 440 N	[55 lbf] 245 N	9:1	6:1
TU	[0.87] 22	[1.06] 27	[1.75] 44,5	[1.38] 35			8.4:1	4:4:1
USS				[2.25] 57	[125 lbf] 560 N	[60 lbf] 270 N	9:1	6:1

Dimensions shown "mm [inch]" ± HC = Holding Capacity, EF = Exerting Force, AF = Applied Force  
See page MC-TEC-4 for additional information.

# 201 SERIES

## Vertical Hold Down Clamps | Dimensions | -U/-UB/-TU/-USS

**201-U**  
Flanged Base  
U-Bar

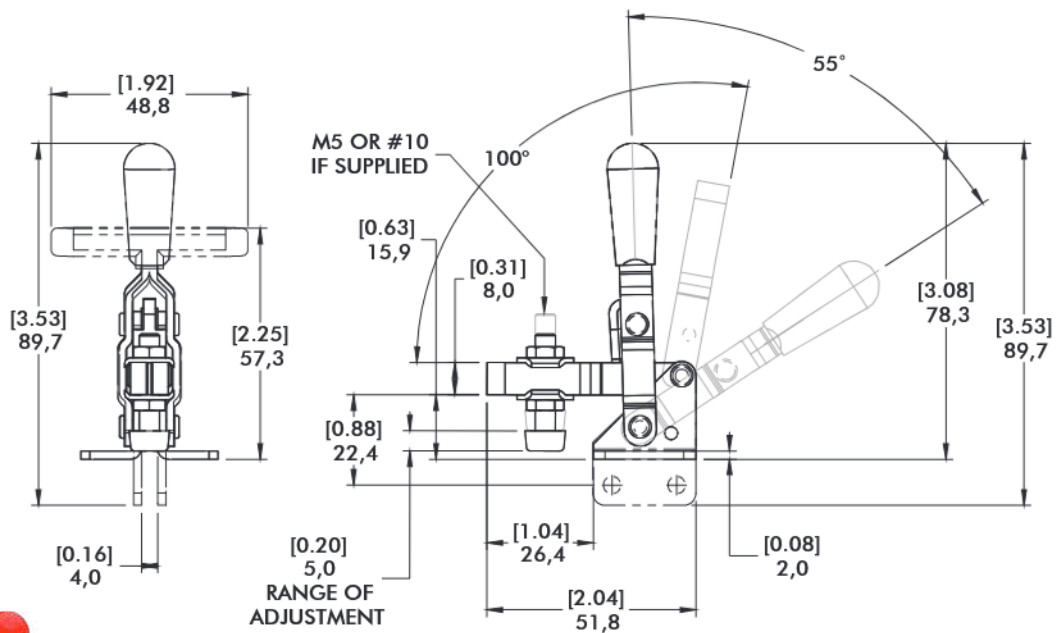
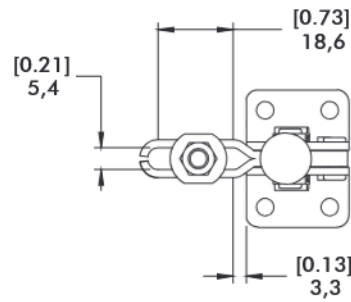

**201-UB**  
Straight Base

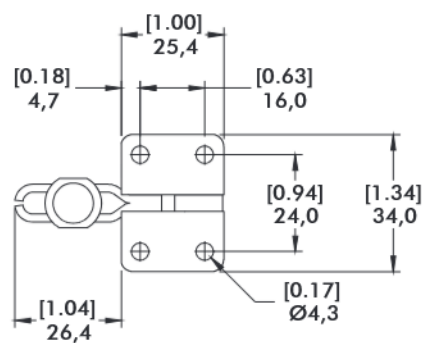

# 202 SERIES

## Vertical Hold Down Clamps | Product Overview

### Features:

- Two bar styles available
- Low profile T-Handle version available
- Available in stainless steel
- Accommodates M6 or 1/4" spindle accessories
- BLK models feature a black, non-reflective finish
- 5 handle colors - see page MC-PRO-7 for details

### Applications:

- Checking fixtures
- Assembly & test
- Light machining
- Woodworking

### Also Available:

See page MC-ACC-1 for accessories  
802-U Pneumatic Toggle Clamp  
(See page MC-PTC-3)

**202-U/USS**  
Flanged Base  
U-Bar



-USS Stainless  
Steel Model



**202-UL**  
Flanged Base  
Long U-Bar



**202/-SS**  
Flange Base  
Solid Bar



-SS Stainless  
Steel Model



**202-UB**  
Straight Base  
U-bar



**202-B**  
Straight Base  
Solid Bar



**202-TU**  
Flanged Base  
U-bar,  
T-Handle



**202-T**  
Flanged Base  
Solid Bar  
T-Handle



**202-U-L<sup>Ⓢ</sup>**  
Flanged Base  
Open U-Bar



**202-U-L-BLK<sup>Ⓢ</sup>**  
Blackout Series  
Flanged Base  
Open U-Bar



**202-UB-L<sup>Ⓢ</sup>**  
Straight Base  
Open U-Bar



**202-UB-L-BLK<sup>Ⓢ</sup>**  
Blackout Series  
Straight Base  
Open U-Bar



**202305**  
Flanged Grip.  
Provides added safety  
and protection. Fits all  
202 Series (except  
T-Handle) clamps.  
Order separately.



### Color Handles

Available on models  
in this series that use  
standard red handles.\*  
Add -Y, -G, -B, -K to  
end of model number.

\*Excludes Blackout Series,  
Toggle Lock Plus levers  
or dipped handles.



<sup>Ⓢ</sup> This item is available upon request

# 202 SERIES

## Vertical Hold Down Clamps | Technical Information

Model	Max. Holding Capacity	Clamp Bar Opening (+10°)	Handle Opening (+10°)	Weight	Accessories (Supplied)			
					Spindle Assembly	Flanged Washers		
202-U	[200 lbf] 890 N	105°	65°	[0.35 lbs] 0,16 kg	202208-M	215105		
202-UL					202943-M	215905		
202-USS	1110 N [250 lbf]							
202	890 N [200 lbf]				[0.33 lbs] 0,15 kg	202208-M	---	
202-SS	1110 N [250 lbf]					205943-M	---	
202-UB	[200 lbf] 890 N				0,16 kg [0.35 lbs]	202208-M	215105	
202-B					0,15 kg [0.33 lbs]			
202-TU					0,17 kg [0.38 lbs]			
202-T								
202-U-L ⓘ								
202-U-L-BLK ⓘ								
202-UB-L ⓘ								
202-UB-L-BLK ⓘ								

ⓘ This item is available upon request

### Holding Capacities

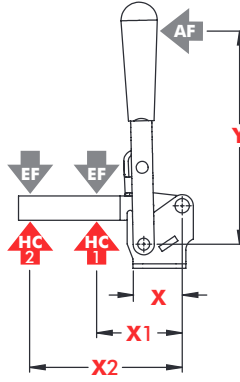

Model	X	X1	X2	Y	±HC1	±HC2	±EF(X1):AF	±EF(X2):AF
202-U			[2.25] 57	[3.42]	[200 lbf] 890 N	[140 lbf] 625N		5:1
202-UL		[1.25] 32	[2.88] 73	87		[150 lbf] 670 N	10:1	4:1
202-USS			[2.25] 57	[3.00] 76	[250 lbf] 1110 N	[170 lbf] 760 N		5:1
202			[1.88] 48	[3.42] 87	---	[200 lbf] 890 N	---	8:1
202-SS				[3.00] 76	---	[250 lbf] 1110 N	---	
202-UB		[1.25] 32	[2.25] 57	[3.42]	[200 lbf] 890 N	[140 lbf] 625N	10:1	5:1
202-B	[0.79] 20		[1.88] 48	87	---	[200 lbf] 890 N	---	8:1
202-TU		[1.25] 32	[2.25] 57	[2.13]	[200 lbf] 890 N	[140 lbf] 625N	11:1	7:1
202-T			[1.88] 48	54	---	[200 lbf] 890 N	---	6:1
202-U-L ⓘ								
202-U-L-BLK ⓘ		[1.25] 32	[2.25] 57	[3.42] 87	[200 lbf] 890 N	[140 lbf] 625N	10:1	5:1
202-UB-L ⓘ								
202-UB-L-BLK ⓘ								

Dimensions shown "mm [inch]" ± HC = Holding Capacity, EF = Exerting Force, AF = Applied Force

ⓘ This item is available upon request

# 202 SERIES

## Vertical Hold Down Clamps | Dimensions | -U/-UL/-USS/-SS/-UB/-B/-TU/-T

**202-U**  
Flanged Base  
U-Bar

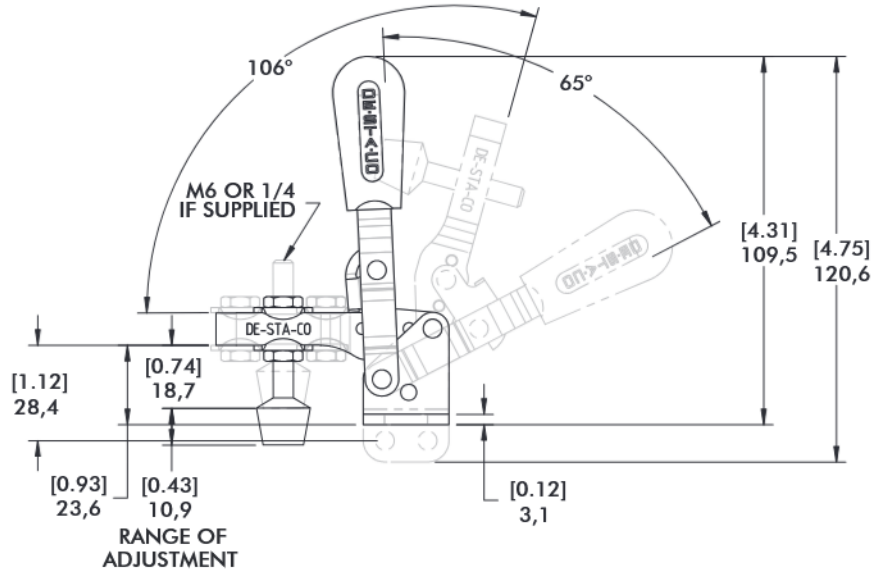
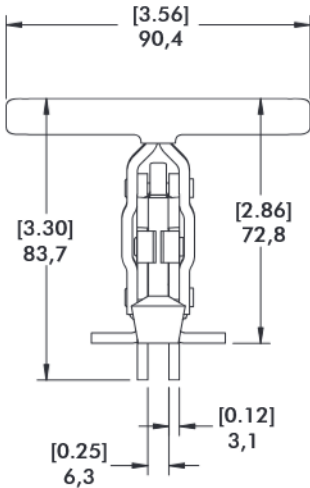
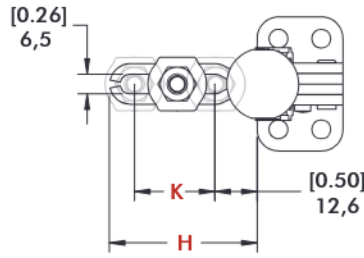

### Open Bar Option



See page MC-ACC-7 for complete offering of open bar accessories

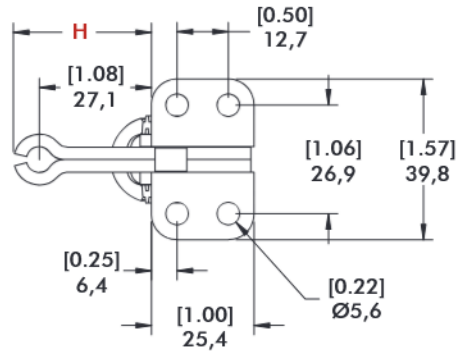



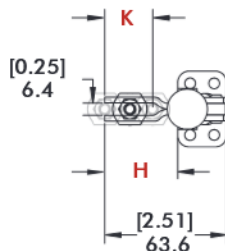

Flanged Base  
**Model**  
202-U-L ⓘ  
202-U-L-BLK ⓘ



Straight Base  
**Model**  
202-UB-L ⓘ  
202-UB-L-BLK ⓘ



Bar Style	Clamp Models	H	K
	202-U/202-UB/ 202-USS/202-TU	[1.73] 43,9	[0.98] 25
	202-UL ⓘ	[2.29] 58,1	[1.51] 38,4
	202/202-B/ 202-T/202-SS	[1.31] 33,3	---
	202-U-L ⓘ/ 202-UB-L ⓘ	[1.50] 38,1	[0.99] 25,1

ⓘ This item is available upon request

# VERTICAL HOLD DOWN CLAMPS

## Application Example

### Application Areas

Clamping during the assembling, drilling, testing, gluing, locking of covers and much more. The vertical clamp is the most frequently used product whenever clamping products are to be integrated with a manual fixture.

### The essential product features

- In the clamping position, the handle is vertical
- Vertical clamps open at an angle between 75° and 215°
- Vertical clamps are offered with U-shaped or heavy-duty solid clamping bars
- Vertical clamps have a straight or flanged base.  
The heavy-duty vertical clamps possess a base that can be welded on without a hole pattern

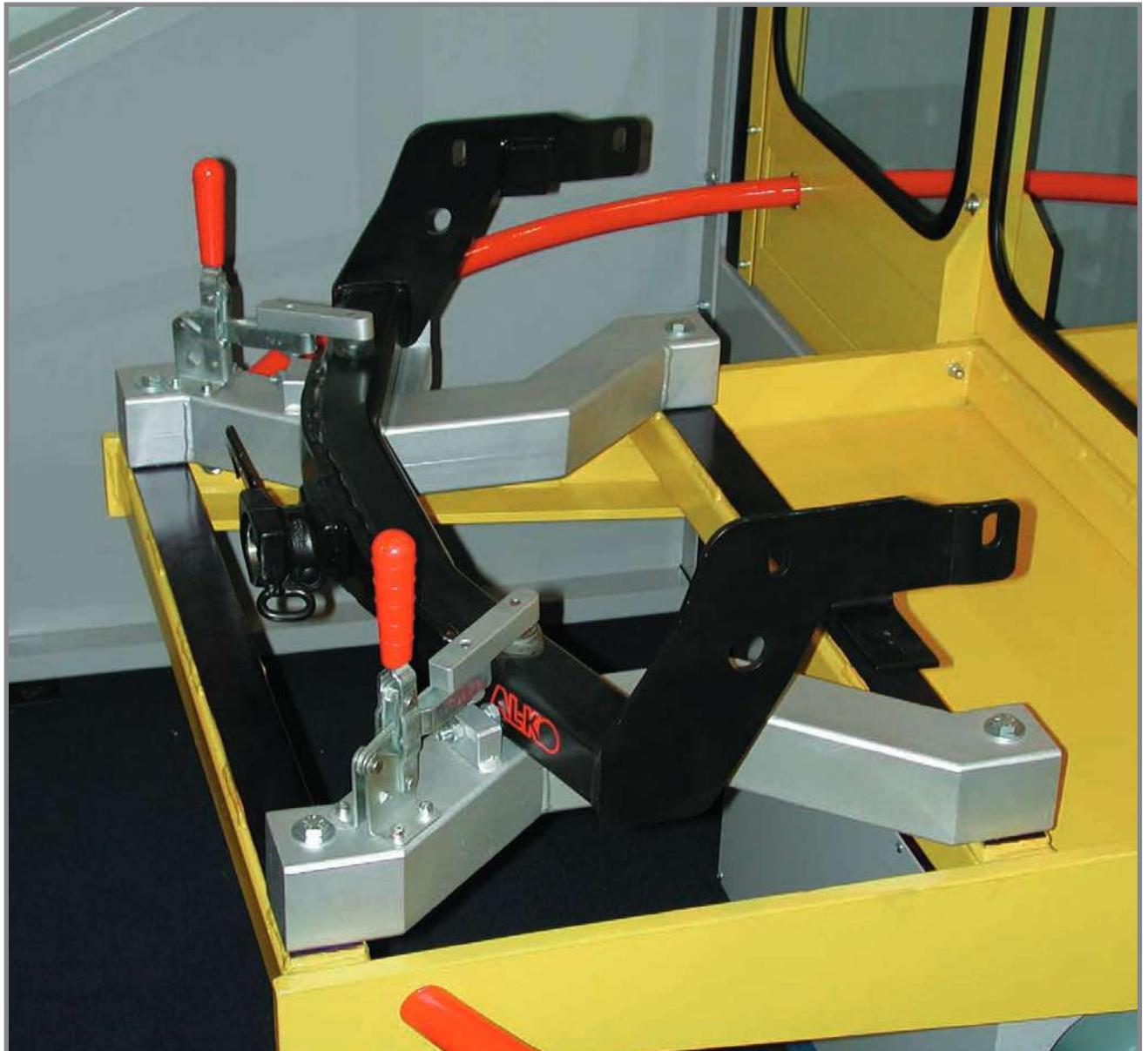



# 207 SERIES

## Vertical Hold Down Clamps | Product Overview

### Features:

- Largest selection of arm and mounting options
- Low profile T-Handle version available
- Available in stainless steel
- BLK models feature a black, non-reflective finish
- 5 handle colors - see page MC-PRO-7 for details

### Applications:

- Checking fixtures
- Assembly & test
- Light machining
- Woodworking

### Also Available:

See page MC-ACC-1 for accessories

**807-U** Pneumatic toggle clamp  
(See page MC-PTC-6)

**807-S** Pneumatic toggle clamp  
(See page MC-PTC-6)

Accepts M8 or 5/16 spindle accessories

**207-U**  
Flanged Base  
U-Bar



-USS Stainless  
Steel Model



**207-UL**  
Flanged Base  
Long U-Bar



**207-S**  
Flanged Base  
Solid Bar



**207-L**  
Flanged Base  
Long Solid Bar



**207-TU**  
Flanged Base  
T-Handle  
U-Bar



**207-TUL**  
Flanged Base  
T-Handle  
Long U-Bar



**207-UR**  
Flanged Base  
U-Bar  
DESTACO®  
Toggle Lock  
Plus



**207-LR**  
Flanged Base  
Long Solid Bar  
DESTACO®  
Toggle Lock  
Plus



**207-UB**  
Straight Base  
U-Bar



**207-ULB**  
Straight Base  
Long U-Bar



**207-SB**  
Straight Base  
Solid Bar



**207-LB**  
Straight Base  
Long Solid  
Bar



**207-LBR** ⓘ  
Straight Base  
Long Solid Bar  
DESTACO®  
Toggle Lock  
Plus



**207-UF** ⓘ  
U-Bar  
Dual Mount



**207-SF** ⓘ  
Solid Bar  
Dual Mount



**207-U-L** ⓘ  
Flange Base  
Open Bar



**207-U-L-BLK**  
Blackout Series  
Flanged Base  
Open U-Bar



**207-UB-L** ⓘ  
Straight Base  
Open Bar



**207-UB-L-BLK**  
Blackout Series  
Straight Base  
Open U-Bar



**207305**  
Flanged Grip. Provides added safety and protection. Fits all 207 Series (except T-Handle) clamps. Order separately.



### Color Handles

Available on models in this series that use standard red handles.\* Add -Y, -G, -B, -K to end of model number.

\*Excludes Blackout Series, Toggle Lock Plus levers or dipped handles.



ⓘ This item is available upon request

# 207 SERIES

## Vertical Hold Down Clamps | Technical Information

Model	Max. Holding Capacity	Clamp Bar Opening (+10°)	Handle Opening (+10°)	Weight	Accessories (Supplied)						
					Bolt Retainer	Spindle Assembly	Flanged Washers				
207-U	[375 lbf] 1670 N	99°	57°	0,30 kg [0.67 lbs]	---	225208-M	507107				
207-UR				0,45 kg [1.00 lbs]							
207-UL				0,30 kg [0.67 lbs]							
207-USS	2000 N [450 lbf]			0,32 kg [0.70 lbs]	---	207943-M	507907				
207-S	[500 lbf] 2220 N			99°	57°	0,31 kg [0.69 lbs]	207105	---	---		
207-L						0,34 kg [0.74 lbs]					
207-LR						0,45 kg [1.00 lbs]					
207-UB	[375 lbf] 1670 N			99°	57°	0,33 kg [0.72 lbs]	---	225208-M	507107		
207-ULB						0,31 kg [0.69 lbs]					
207-SB	[500 lbf] 2220 N					99°	57°	0,31 kg [0.69 lbs]	207105	---	---
207-LB		0,34 kg [0.75 lbs]									
207-LBR ⓘ		0,45 kg [1.00 lbs]									
207-TU	[375 lbf] 1670 N	96°	56°			0,33 kg [0.72 lbs]	---	---	507107		
207-TUL						0,33 kg [0.72 lbs]					
207-UF ⓘ	1670 N [375 lbf]					96°	56°	0,43 kg [0.94 lbs]	---	225208-M	507107
207-SF ⓘ	2220 N [500 lbf]					90°		0,38 kg [0.84 lbs]	207105	---	---
207-U-L ⓘ	[375 lbf] 1670 N					99°	57°	0,38 kg [0.84 lbs]	---	---	507107
207-U-L-BLK ⓘ				507107-BLK							
207-UB-L ⓘ				507107							
207-UB-L-BLK ⓘ				507107-BLK							

ⓘ This item is available upon request

### Holding Capacities

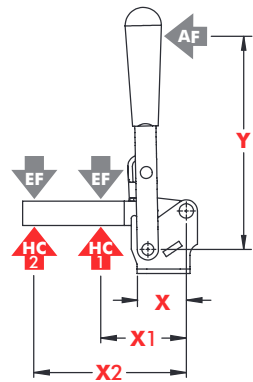

Model	X	X1	X2	Y	±HC1	±HC2	±EF(X1):AF	±EF(X2):AF
U/UB/UR	[1.28] 32,6	[2.00] 50,8	[3.75] 95,3	[4.90] 124,5	[375 lbf] 1670 N	[225 lbf] 1000 N	12:1	6:1
UL/ULB		[3.88] 98,5	[5.00] 127		[150 lbf] 670 N	7:1	4:1	
USS		[2.00] 50,8	[3.75] 95,3		[450 lbf] 2000 N	[240 lbf] 1070 N	10:1	7:1
S/SB		[2.88] 73,0	[5.00] 127	[500 lbf] 2220 N	[350 lbf] 1560 N			
L/LR LB/LBR		[2.88] 73,0	[5.00] 127	[3.66] 9	[375 lbf] 1670 N	[225 lbf] 1000 N	6:1	4:1
TU		[2.00] 50,8	[3.75] 95,3		[150 lbf] 670 N	4:1	3:1	
TUL		[3.88] 98,5	[5.00] 127	[4.90] 124,5	[375 lbf] 1670 N	[225 lbf] 1000 N	12:1	6:1
U-L		[2.00] 50,8	[3.75] 95,3		[225 lbf] 1000 N			
UB-L		[2.00] 50,8	[3.75] 95,3					

Dimensions shown "mm [inch]" ± HC = Holding Capacity, EF = Exerting Force, AF = Applied Force

# 207 SERIES



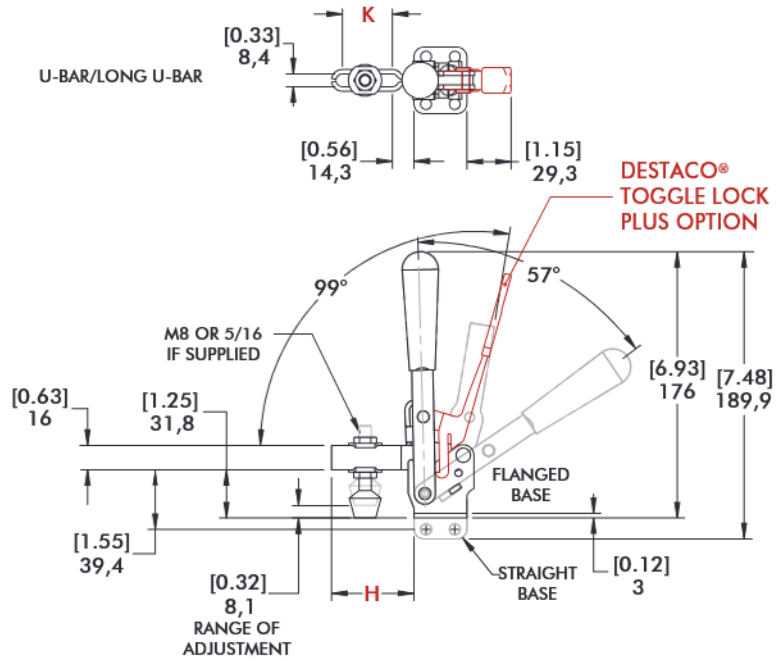
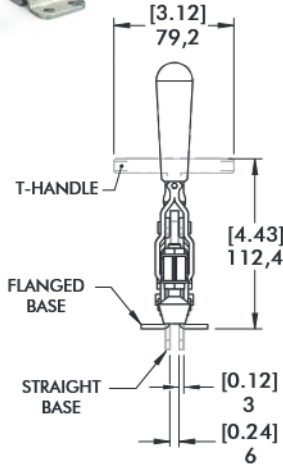

Vertical Hold Down Clamps | Dimensions | -U/-UL/-S/-L/-TU/-TUL/-UR/-LR/-UB/-ULB/-SB/-LB/-LBR

**207-U**  
Flanged Base  
U-Bar

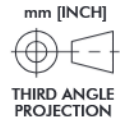
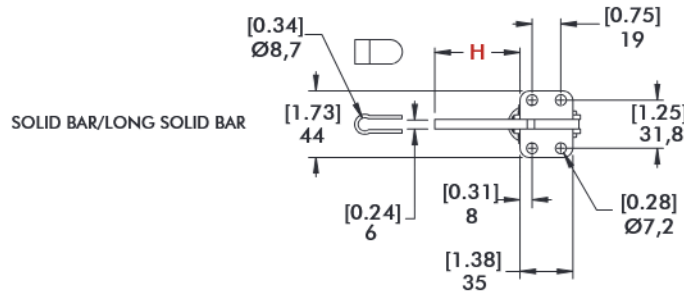

**207-SB**  
Straight Base  
Solid Bar



Bar Style	Clamp Models	H	K
	207-U/207-UR/207-TU/207-UB	[2.14] 54,4	[1.30] 33
	207-UL/207-ULB/207-TUL	[3.84] 97,6	[2.94] 74,6
	207-S/207-SB	[2.21] 56,2	---
	207-L/207-LR/207-LB/207-LBR ⓘ	[3.48] 88,4	---

ⓘ This item is available upon request

# 207 SERIES

## Vertical Hold Down Clamps | Dimensions | Dual Mount

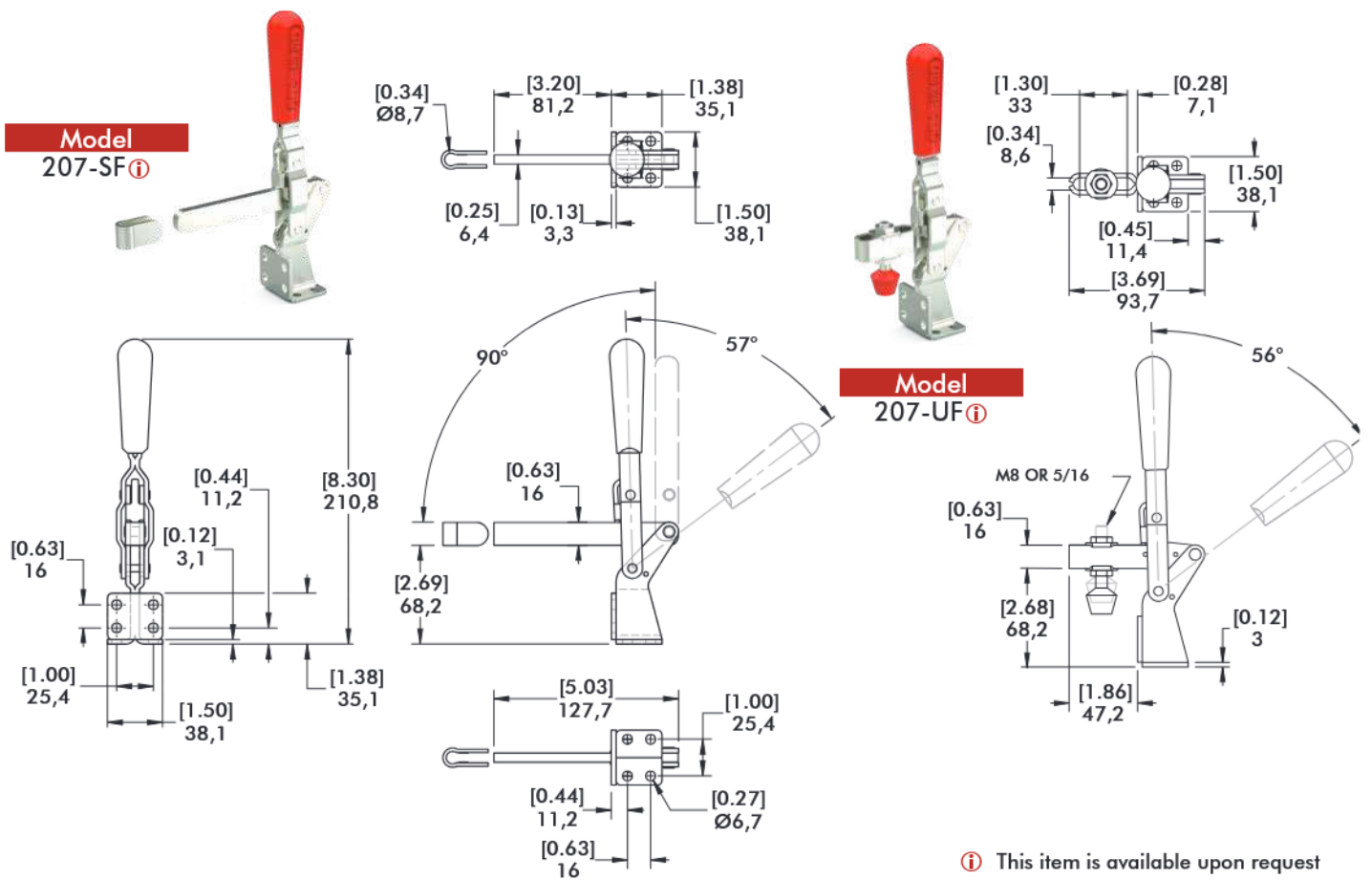

### Open Bar Option

See page MC-ACC-7 for Complete offering of Open bar accessories

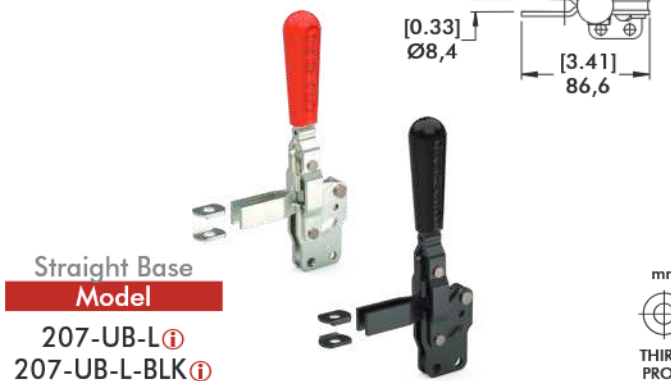

### Stainless Steel

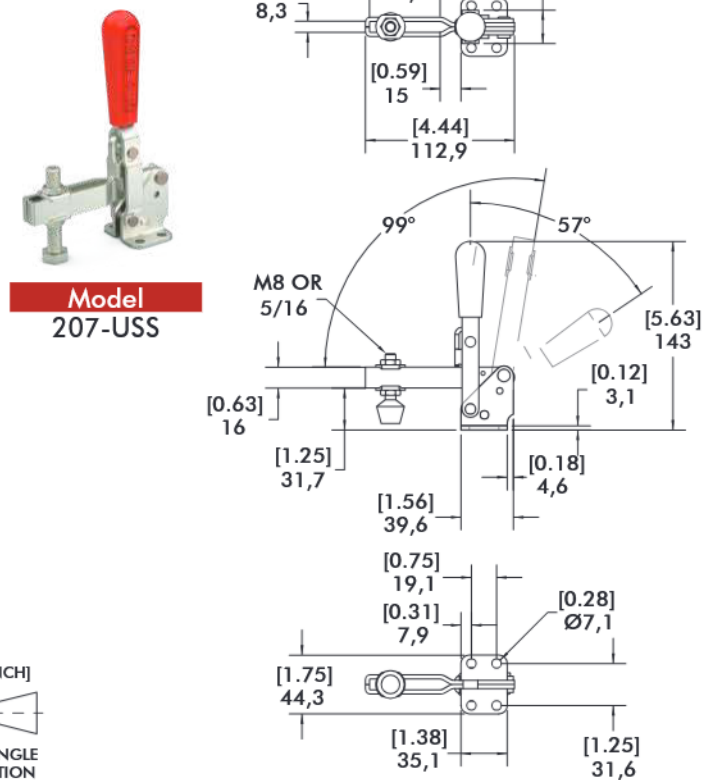

# 210 SERIES

## Vertical Hold Down Clamps | Product Overview

### Features:

- DESTACO® Toggle Lock Plus™ versions available
- Available in stainless steel
- Accommodates M10 or 3/8 spindle accessories
- 5 handle colors - see page MC-PRO-7 for details

### Applications:

- Assembly & test
- Light machining
- Light welding

### Also Available:

See page MC-ACC-1 for accessories  
 810-U Pneumatic Toggle Clamp  
 (See page MC-PTC-7)  
 810-S Pneumatic Toggle Clamp  
 (See page MC-PTC-7)

**210-U/USS**  
 Flanged Base  
 U-Bar



-USS Stainless Steel Model

**210-S**  
 Flanged Base  
 Solid Bar



**210-UB**  
 Straight Base  
 U-bar



**210-SB**  
 Straight Base  
 Solid Bar



**210-UR**  
 Flanged Base  
 U Bar  
 DESTACO®  
 Toggle Lock  
 Plus



**210-SR**  
 Flanged Base  
 Solid Bar  
 DESTACO®  
 Toggle Lock  
 Plus



**210-TU**  
 Flanged Base  
 U Bar  
 T-Handle



### Color Handles

Available on models in this series that use standard red handles.\* Add -Y, -G, -B, -K to end of model number.

\*Excludes Blackout Series, Toggle Lock Plus levers or dipped handles.



## Technical Information

Model	Max. Holding Capacity	Clamp Bar Opening (+10°)	Handle Opening (+10°)	Weight	Accessories (Supplied)		
					Bolt Retainer	Spindle Assembly	Flanged Washers
210-U	2670 N [600 lbf]	103°	58°	[1.29 lbs] 0,59 kg	---	240208-M	235106
210-USS	[750 lbf]				---	237943-M	235906
210-S	3340 N				210114	237943-M	---
210-UB	2670 N [600 lbf]				---	240208-M	235106
210-SB	3340 N [750 lbf]			210114	---	---	
210-UR	2670 N [600 lbf]			---	240208-M	235106	
210-SR	3340 N [750 lbf]			210114	---	---	
210-TU	2670 N [600 lbf]			---	---	235106	
				0,62 kg [1.36 lbs]	---	---	

# 210 SERIES

## Vertical Hold Down Clamps | Holding Capacities

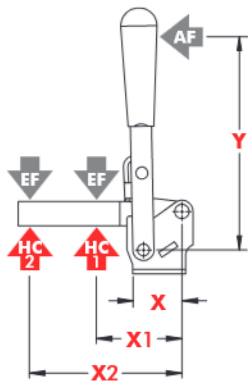

Model	X	X1	X2	Y	±HC1	±HC2	±EF(X1):AF	EF(X2):AF
U/UB/UR	[1.54] 39	[2.38] 60,5	[4.88] 124	[6.75] 171,5	[600 lbf] 2670 N	[290 lbf] 1290 N	14:1	7:1
USS		[3.62] 92,0	[5.25] 133	[4.50] 114,5	[750 lbf] 3340 N	[360 lbf] 1600 N		
S/SR/SB		[2.38] 60,5	[4.88] 124		[600 lbf] 2670 N	[290 lbf] 1290 N	11:1	5:1
TU								

Dimensions shown "mm [inch]" ± HC = Holding Capacity, EF = Exerting Force, AF = Applied Force  
See page MC-TEC-4 for additional information.

## Dimensions | -U/-USS/-S/-UB/-SB/-UR/-SR/-TU

**210-U**  
Flanged Base  
U-Bar

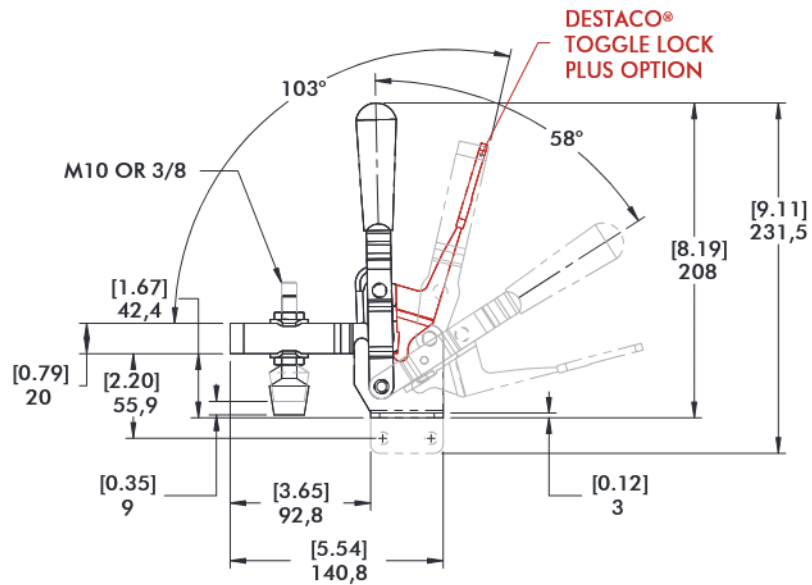
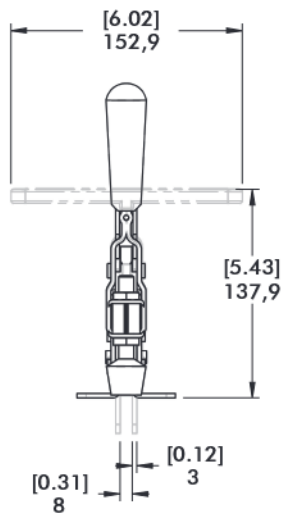
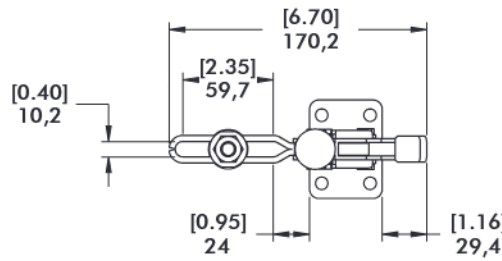

**210-SR**  
Flanged Base  
Solid Bar  
with  
DESTACO®  
Toggle Lock  
Plus™

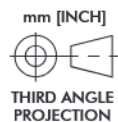
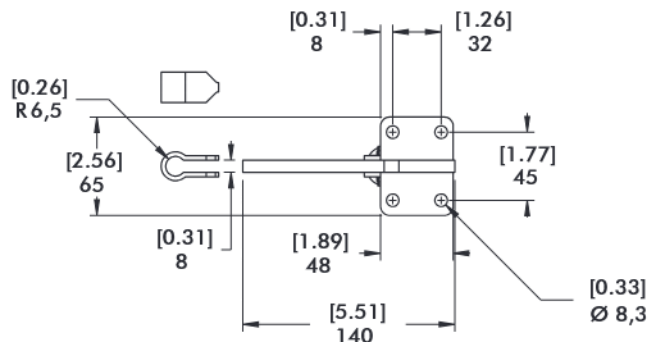

# 247, 267 SERIES

## Vertical Hold Down Clamps | Product Overview

### Features:

- Hardened steel bushings
- Large bar guides for greater lateral stability on Model 247
- Series 247 accommodates M12 or 1/2 spindle accessory
- Series 267 accommodates M16 or 5/8 spindle accessory
- 5 handle colors - see page MC-PRO-7 for details

### Applications:

- Assembly & test
- Light machining
- Welding

### Also Available:

See page MC-ACC-1 for accessories  
 847-U Pneumatic Toggle Clamp (See page MC-PTC-13)  
 847-S Pneumatic Toggle Clamp (See page MC-PTC-13)

#### 247-U

Flanged Base  
U-Bar



#### 247-S

Flanged Base  
Solid Bar



#### 267-U

Flanged Base  
U-Bar



#### 267-S<sup>①</sup>

Flanged Base  
Solid Bar



### Color Handles

Available on models in this series that use standard red handles.\* Add -Y, -G, -B, -K to end of model number.

\*Excludes Blackout Series, Toggle Lock Plus levers or dipped handles.



### Note:

Clamps shown with included accessories.

## Technical Information

Model	Max. Holding Capacity	Clamp Bar Opening (+10°)	Handle Opening (+10°)	Weight	Accessories (Supplied)		
					Bolt Retainer	Spindle Assembly	Flanged Washers
247-U	[1000 lbf] 4400 N	120°	67°	1,07 kg [2.36 lbs]	---	247208-M	247109
247-S				1,08 kg [2.36 lbs]	247110	---	---
267-U	[1200 lbf] 5340 N	140°	72°	2,18 kg [4.80 lbs]	---	267203-M	267102
267-S <sup>①</sup>				1,98 kg [4.36 lbs]	110122	---	---

<sup>①</sup> This item is available upon request

## Holding Capacities

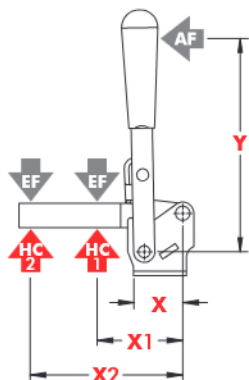

Model	X	X1	X2	Y	±HC1	±HC2	±EF(X1):AF	±EF(X2):AF
247-U	[1.69] 43	[3.00] 76,2	[6.13] 155,7	[6.71] 170,5	[1000 lbf] 4450 N	[480 lbf] 2140 N	12:1	6:1
247-S		[4.56] 115,8	[7.00] 177,8			[650 lbf] 2900 N	10:1	5:1
267-U	[2.50] 63,5	[4.00] 101,6	[8.00] 203,2	[9.25] 235	[1200 lbf] 5340 N	[600 lbf] 2670 N	18:1	8:1
267-S <sup>①</sup>		[6.00] 152,4	[8.75] 222,3			[820 lbf] 3650 N	12:1	

Dimensions shown "mm [inch]" ± HC = Holding Capacity, EF = Exerting Force, AF = Applied Force  
 See page MC-TEC-4 for additional information. <sup>①</sup> This item is available upon request

# 247, 267 SERIES

## Vertical Hold Down Clamps | Dimensions | -U/-S/-UB

**247-U**  
Flanged Base  
U-Bar

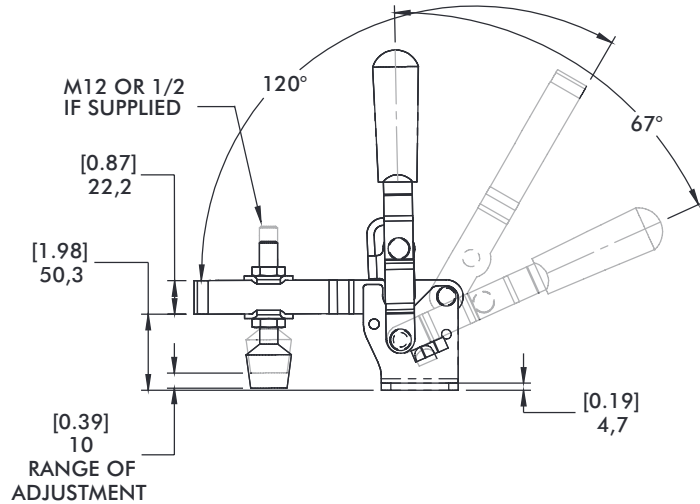
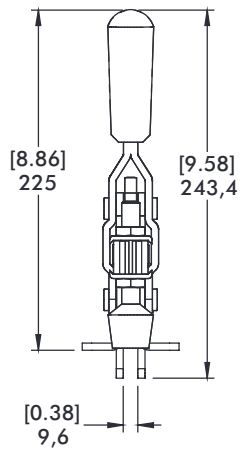
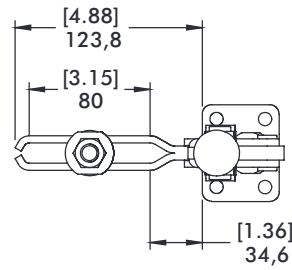

**247-S**  
Flanged Base  
Solid Bar

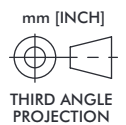
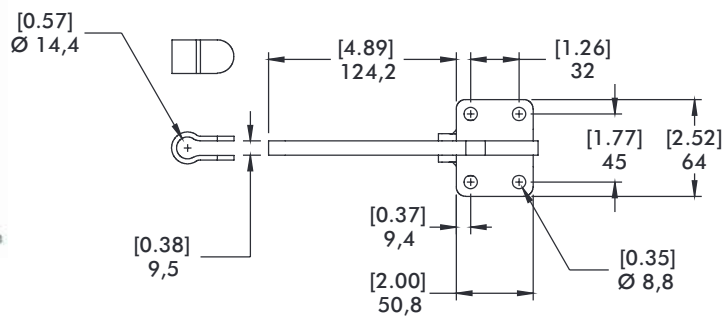



# 267 SERIES

## Vertical Hold Down Clamps | Dimensions

**267-U**  
Flanged Base  
U-Bar

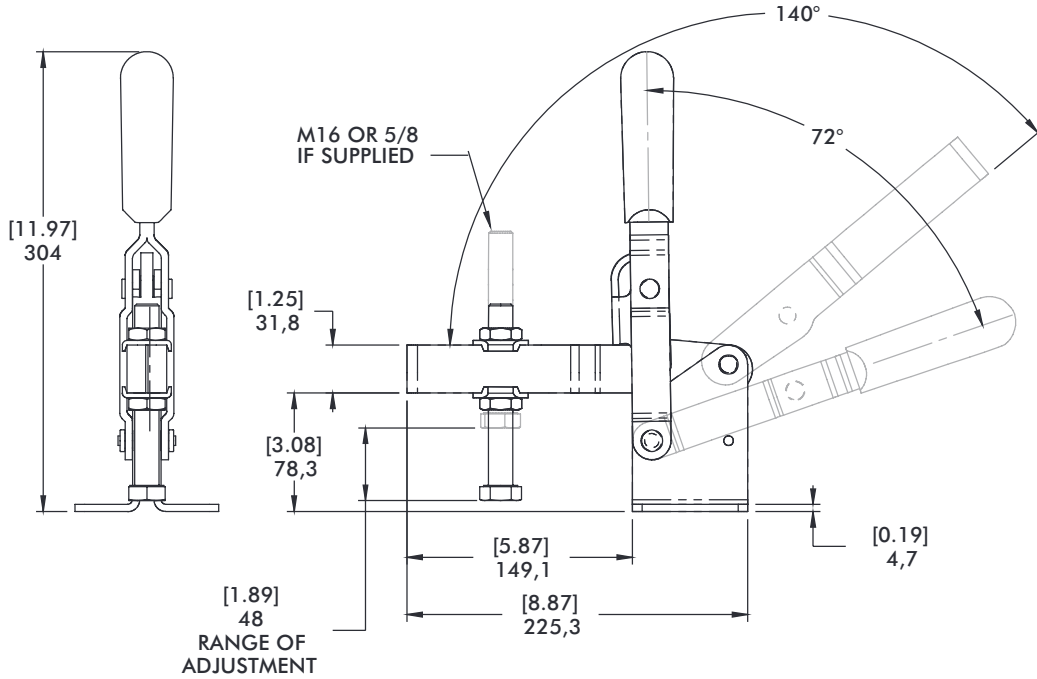
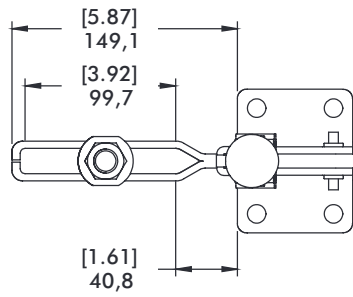

**267-S** ⓘ  
Flanged Base  
Solid Bar

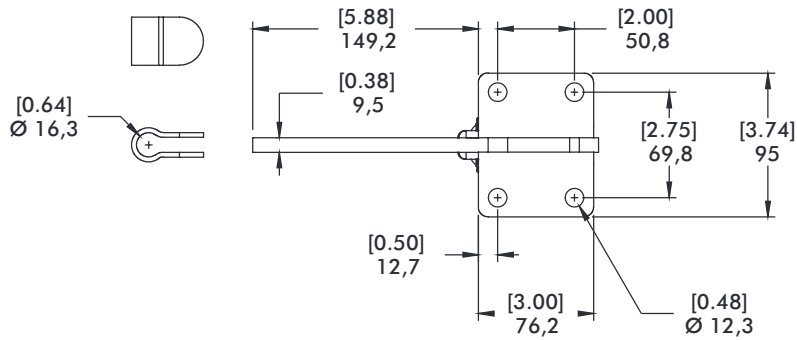

mm [INCH]  
THIRD ANGLE PROJECTION

# VERTICAL HOLD DOWN CLAMPS

## Application Examples



**Model 210-U**  
used in an airframe  
assembly fixture

**Model 210-U**  
shown being used  
in a checking fixture  
application.

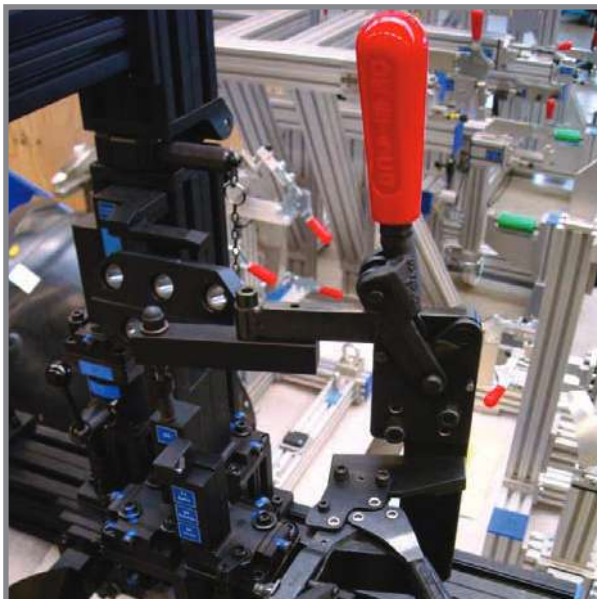

**Model 533-LB**  
and **227-UB** shown  
with black finish in  
a fixture for used for  
optical inspection.

# 5905, 5910, 5915 SERIES

## Heavy-Duty Vertical Hold Down Clamps | Product Overview

### Features:

- High strength forged clamping arm for heavy-duty service
- Hardened steel pivot pins and bushings provide long life
- Black oxide finish
- 5 handle colors - see page MC-PRO-7 for details

### Applications:

- Welding fixtures
- Assembly fixtures



5905/5910/5915  
Flanged Base



5905-B/5910-B/5915-B  
Solid Base



### Color Handles

Available on models in this series that use standard red handles.\* Add -Y, -G, -B, -K to end of model number.

\*Excludes Blackout Series, Toggle Lock Plus levers or dipped handles.



## Technical Information

Model	Max. Holding Capacity	Clamp Bar Opening (+10°)	Handle Opening (+10°)	Weight
5905	[750 lbf] 3340N	135°	70°	[1.08 lbs] 0,49 kg
5905-B				[0.82 lbs] 0,37 kg
5910	[1600 lbf] 7120N	132°	71°	[2.84 lbs] 1,29 kg
5910-B				[2.24 lbs] 1,02 kg
5915	[2750 lbf] 12230N	147°	74°	[6.16 lbs] 2,79 kg
5915-B				[5.11 lbs] 2,32 kg



Removable handle stop can be repositioned to limit opening angle to 90°

## Holding Forces

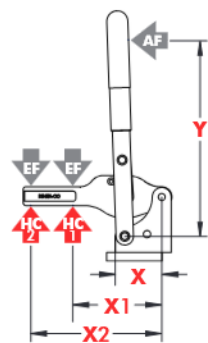

Model	X	X1	X2	Y	±HC1	±HC2	±EF(X1):AF	±EF(X2):AF
5905	[1.25] 31.9	[2.44] 62	[3.46] 88	[5.31] 135	[750 lbf] 3340 N	[525 lbf] 2335 N	10:1	8:1
5910	[1.87] 47.6	[3.34] 85	[5.12] 130	[6.88] 175	[1600 lbf] 7120 N	[1025 lbf] 4550 N	12:1	5:1
5915	[2.50] 63.5	[4.49] 114	[6.89] 175	[9.05] 230	[2750 lbf] 12230 N	[1790 lbf] 7960 N	10:1	7:1

Dimensions shown "mm [inch]" ± HC = Holding Capacity, EF = Exerting Force, AF = Applied Force  
See page MC-TEC-4 for additional information.

# 5905, 5910, 5915 SERIES

## Heavy-Duty Vertical Hold Down Clamps | Dimensions

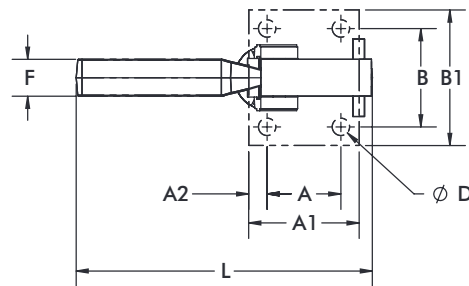
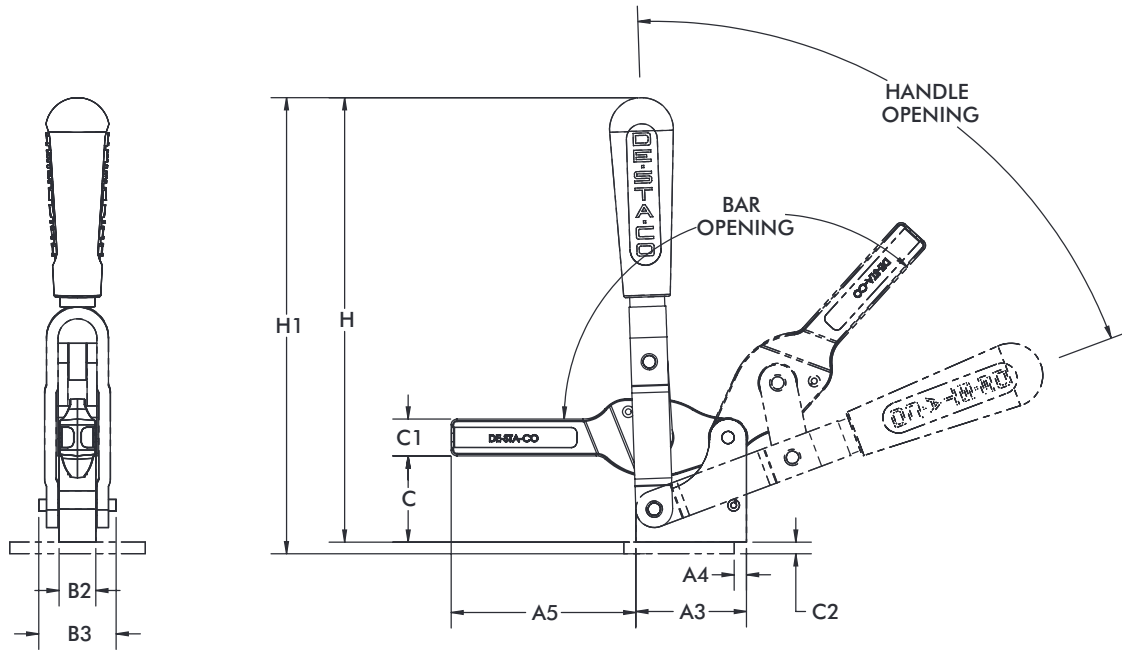

mm [INCH]  
THIRD ANGLE PROJECTION

Model	A	A1	A2	A3	A4	A5	B	B1	B2	B3	C	C1	C2	D	F	H	H1	L
5905	[1.00] 25,4	[1.50] 38,1	[0.25] 6,4	[1.51] 38,4	[0.25] 6,4	[2.49] 63,2	[1.50] 38,1	[2.13] 54,1	[0.59] 15,0	[1.02] 25,9	[1.27] 32,3	[0.51] 12,9	[0.24] 6,1	[0.29] 7,3	[0.56] 14,2	[6.51] 165,4	[6.75] 171,4	[4.02] 102,10
5910	[1.50] 38,1	[2.24] 56,9	[0.37] 9,4	[2.25] 57,2	[0.25] 6,4	[3.76] 95,5	[2.00] 50,8	[2.76] 70,1	[0.75] 19,1	[1.57] 39,9	[1.75] 44,5	[0.75] 19,1	[0.24] 6,1	[0.41] 10,5	[0.75] 19,1	[9.04] 229,5	[9.27] 235,5	[6.02] 152,88
5915	[2.00] 50,8	[2.95] 74,9	[0.48] 12,2	[2.99] 75,9	[0.38] 9,7	[5.00] 127,0	[2.75] 69,9	[3.88] 98,6	[0.98] 24,9	[1.97] 50,0	[2.37] 60,2	[1.00] 25,4	[0.35] 8,9	[0.55] 14,0	[1.00] 25,4	[10.89] 276,7	[11.25] 285,7	[7.50] 190,50

Model	A3	A5	B2	B3
5905-B	[1.51] 38,4	[2.49] 63,2	[0.59] 15,0	[1.02] 25,9
5910-B	[2.25] 57,2	[3.76] 95,5	[0.75] 19,1	[1.57] 39,9
5915-B	[2.99] 76	[4.92] 125	[0.98] 25	[1.97] 50

# 5105, 5110 SERIES

## Heavy-Duty Vertical Hold Down Clamps | Product Overview

### Features:

- High strength forged clamping arm for heavy-duty service
- Hardened steel pivot pins and bushings provide long life
- Black oxide finish
- Large clearance under the clamping bar
- DESTACO® Toggle Lock Plus™ versions available†

### Applications:

- Welding fixtures
- Assembly fixtures



Covered under one or more U.S./International Patents

5105/5110  
Flanged Base



5105-B/5110-B  
Solid Base



5105-R/5110-R  
Flanged Base  
DESTACO®  
Toggle Lock  
Plus™



5105-BR①/5110-BR①  
Solid Base  
DESTACO®  
Toggle Lock  
Plus™



## Technical Information

Model	Max. Holding Capacity	Clamp Bar Opening (+10°)	Handle Opening (+10°)	Weight
5105	[700 lbf] 3100 N	89°	159°	[1.12 lbs] 0,51 kg
5105-B				[1.06 lbs] 0,48 kg
5105-R				[1.10 lbs] 0,50 kg
5105-BR①				[1.17 lbs] 0,53 kg
5110	[1150 lbf] 5100 N	74°	138°	[2.98 lbs] 1,35 kg
5110-B				[2.95 lbs] 1,34 kg
5110-R				[3.00 lbs] 1,36 kg
5110-BR①				[3.02 lbs] 1,37 kg

① This item is available upon request.

† Toggle Lock Plus™ locks the handle in the closed position only.

## Holding Forces

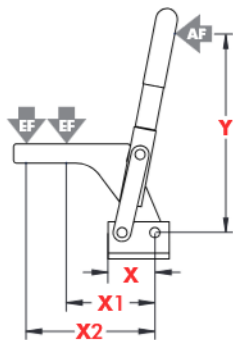

Model	X	X1	X2	Y	±HC1	±HC2	±EF(X1):AF	±EF(X2):AF
5105	[1.24] 31.5	[2.28] 58	[3.38] 86	[5.31] 135	[700 lbf] 3100 N	[475 lbf] 2100 N	14:1	10:1
5110	[1.85] 47	[3.23] 82	[5.24] 133	[6.69] 170	[1150 lbf] 5100 N	[700 lbf] 3100 N	15:1	10:1

Dimensions shown "mm [inch]" ± HC = Holding Capacity, EF = Exerting Force, AF = Applied Force  
See page MC-TEC-4 for additional information.

# 5105, 5110 SERIES

## Heavy-Duty Vertical Hold Down Clamps | Dimensions

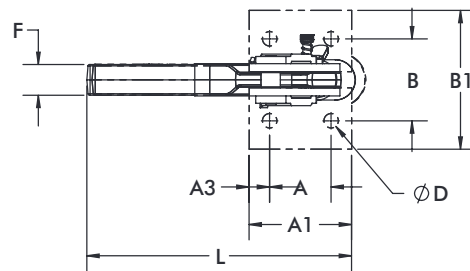
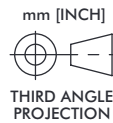
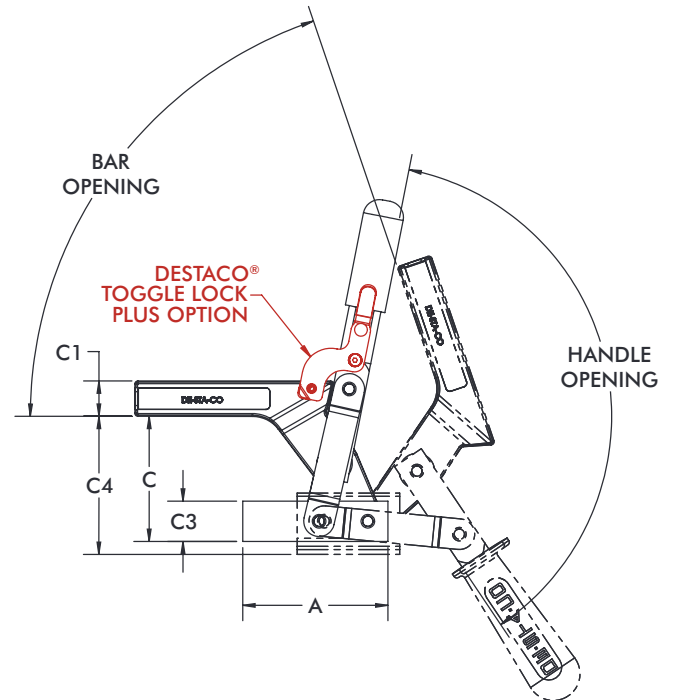
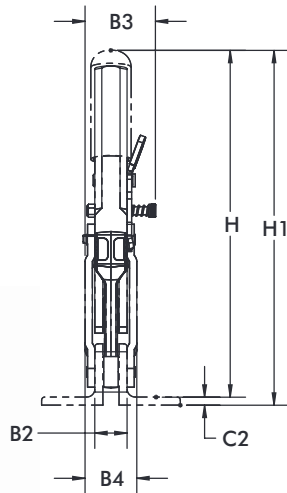

Model	A	A1	A2	B	B1	B2	B3	B4	C1	C2	C4	D	F	H1	L
5105	[1.00]	[1.62]	[0.31]	[1.46]	[2.24]	[0.59]	--	[0.98]	[0.51]	[0.16]	[2.54]	[0.26]	[0.56]	[6.54]	[4.13]
5105-R	25,4	41,2	7,9	37	57	15	[1.48] 37,5	25	13,0	4,0	64,6	6,6	14,3	166,1	104,9
5110	[1.50]	[2.50]	[0.50]	[2.00]	[2.76]	[0.79]	--	[1.26]	[0.87]	[0.20]	[3.37]	[0.35]	[0.75]	[8.70]	[6.33]
5110-R	38,1	63,5	12,7	50,8	70	20	[1.67] 42,5	32	22,0	5,0	85,6	9,0	19,1	221,1	160,9

Model	A3	B2	B3	B4	C	C1	C3	F	H
5105-B	[2.50]	[0.59]	--	[0.98]	[2.14]	[0.51]	[0.59]	[0.56]	[6.14]
5105-BR <sup>①</sup>	63,5	15	[1.48] 37,5	25	54,3	13,0	15,0	14,3	156,0
5110-B	[3.54]	[0.79]	--	[1.26]	[3.05]	[0.87]	[0.98]	[0.75]	[8.39]
5110-BR <sup>①</sup>	90	20	[1.67] 42,5	32	77,5	22,0	25,0	19,1	213,0

<sup>①</sup> This item is available upon request

# 528 SERIES

## Heavy-Duty Vertical Hold Down Clamps | Product Overview

### Features:

- Hardened steel bushings at pivot points for long life
- Solid bar may be modified to suit application requirements

### Applications:

- Assembly & test
- Light machining
- Welding
- Medium to heavy duty clamping requirements

528  
Flanged Base  
Solid Bar



528-F ⓘ  
Front Mount  
Base Solid Bar



### Technical Information

Model	Max. Holding Capacity	Clamp Bar Opening (+10°)	Handle Opening (+10°)	Weight
528	[1000 lbf] 4450 N	180°	177°	[2.50 lbs] 1,13 kg
528-F ⓘ				

ⓘ This item is available upon request

### Holding Capacities | Dimensions

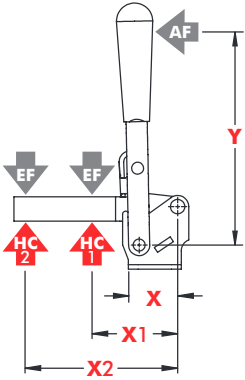

Model	X	X1	X2	Y	±HC1	±HC2	±EF(X1):AF	±EF(X2):AF
528	[1.38]	[3.50]	[6.00]	[5.50]	[1000 lbf]	[580 lbf]	23:1	12:1
528-F	35	89	152	140	4450 N	2580 N		

Dimensions shown "mm [inch]" ± HC = Holding Capacity, EF = Exerting Force, AF = Applied Force  
See page MC-TEC-4 for additional information.

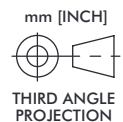
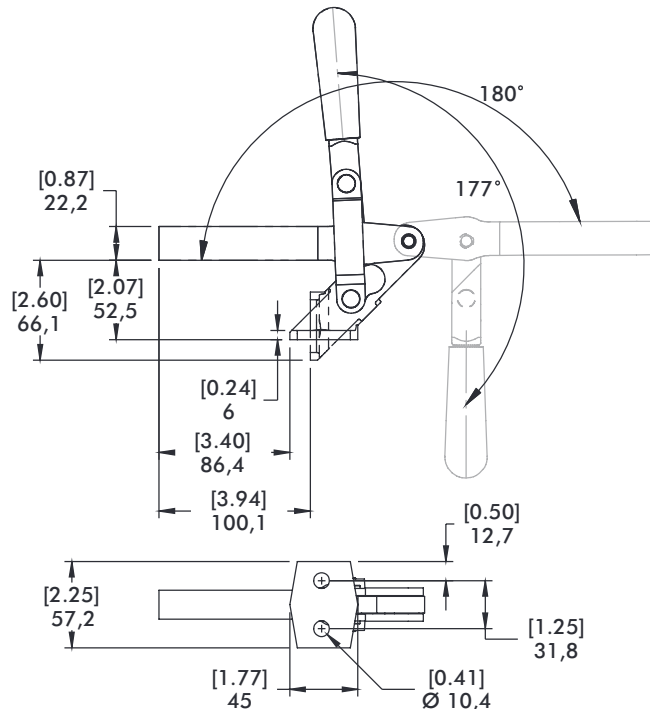
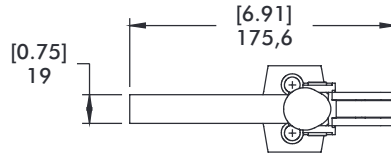
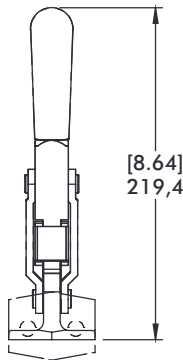

# 548, 578 SERIES

## Heavy-Duty Vertical Hold Down Clamps | Product Overview

### Features:

- Large bar guides for lateral stability
- Hardened steel pins and bushings for long life
- Replaceable pins

### Applications:

- Assembly & test
- Light machining
- Welding
- Heavy duty clamping requirements

548  
Straight Base  
Solid Bar



578  
Straight Base  
Solid Bar



### Technical Information

Model	Max. Holding Capacity	Clamp Bar Opening (+10°)	Handle Opening (+10°)	Weight
548	[2500 lbf] 11100 N	199°	129°	2,40 kg [5.30 lbs]
578	[4000 lbf] 17800 N			4,14 kg [9.12 lbs]

### Holding Capacities | Dimensions

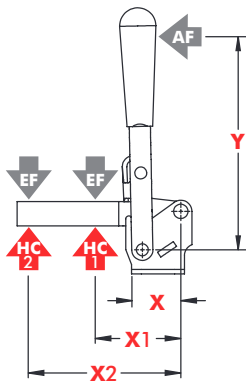

Model	X	X1	X2	Y	±HC1	±HC2	±EF(X1):AF	±EF(X2):AF
548	[2.75] 70	[3.50] 89	[6.00] 152	[7.50] 190	[2500 lbf] 11100 N	[1500 lbf] 6680 N	4.5:1	3.4:1
578	[4.25] 108	[4.50] 114	[7.00] 178	[10.31] 262	[4000 lbf] 17800 N	[2500 lbf] 11100 N	7.6:1	4.2:1

Dimensions shown "mm [inch]" ± HC = Holding Capacity, EF = Exerting Force, AF = Applied Force  
See page MC-TEC-4 for additional information.

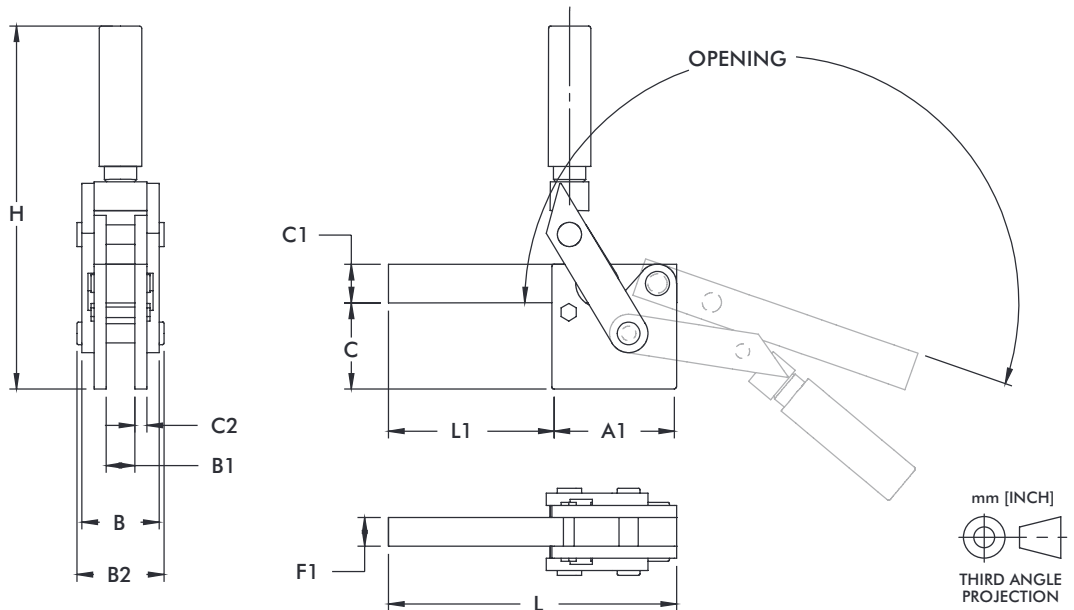

mm [INCH]  
THIRD ANGLE PROJECTION

Model	A1	B	B1	B2	C	C1	C2	F1	H	L	L1
548	[3.25] 82,6	[2.01] 51	[0.75] 19,1	[2.26] 57,5	[2.24] 56,9	[1.00] 25,4	[0.31] 7,9	[0.75] 19,1	[9.45] 240	[7.50] 190,5	[4.25] 107,9
578	[4.02] 102,1	[2.38] 60,5	[0.87] 22,1	[2.70] 68,6	[2.79] 70,9	[1.26] 32	[0.37] 9,5	[0.87] 22,1	[11.04] 280,3	[8.62] 219	[4.61] 117,1



# 533, 535 SERIES

## Heavy-Duty Vertical Hold Down Clamps | Product Overview

### Features:

- Hardened steel bushings and pivot pins
- Large bar guides for greater lateral support
- Solid clamping bar may be modified to suit application requirements
- DESTACO® Toggle Lock Plus™ (533-LBR)
- 5 handle colors - see page MC-PRO-7 for details

### Applications:

- Welding
- Heavy duty clamping applications

### Also Available:

See page MC-ACC-1 for accessories

**533-L**  
Flanged Base  
Solid Bar



**533-LB**  
Straight Base  
Solid Bar



**533-LBR**  
Straight Base  
Solid Bar  
DESTACO®  
Toggle Lock  
Plus™



### Color Handles

Available on models in this series that use standard red handles.\* Add -Y, -G, -B, -K to end of model number.

\*Excludes Blackout Series, Toggle Lock Plus levers or dipped handles.



**535-L**  
Flanged Base  
Solid Bar



**535-LB**  
Straight Base  
Solid Bar



## Technical Information

Model	Max. Holding Capacity	Clamp Bar Opening (+10°)	Handle Opening (+10°)	Weight	Accessories (Supplied)
					Bolt Retainer
533-L	[1575 lbf] 7000 N	120°	90°	[2.20 lbs] 1,00 kg	533108-M
533-LB		90°	74°	1,26 kg [2.78 lbs]	
533-LBR					
535-L	[2250 lbf] 10000 N	120°	90°	[4.087 lbs] 1,85 kg	535108-M
535-LB					

## Holding Forces

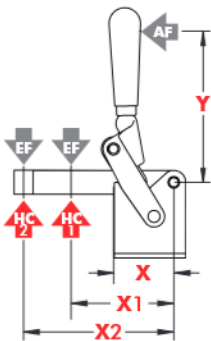

Model	X	X1	X2	Y	±HC1	±HC2	±EF(X1):AF	±EF(X2):AF
533-L	[1.97] 50	[3.25] 82.5	[4.82] 122.5	[5.51] 140	[1575 lbf] 7000 N	[700 lbf] 3100 N	9:1	5:1
535-L	[2.46] 62.5	[4.23] 107.5	[6.20] 157.5	[6.22] 158	[2250 lbf] 10000 N	[1500 lbf] 6600 N	8:1	6:1

Dimensions shown "mm [inch]" ± HC = Holding Capacity, EF = Exerting Force, AF = Applied Force  
See page MC-TEC-4 for additional information.

# 533, 535 SERIES

## Heavy-Duty Vertical Hold Down Clamps | Dimensions

**533-L**  
Flanged Base  
Solid Bar



**535-L**  
Flanged Base  
Solid Bar

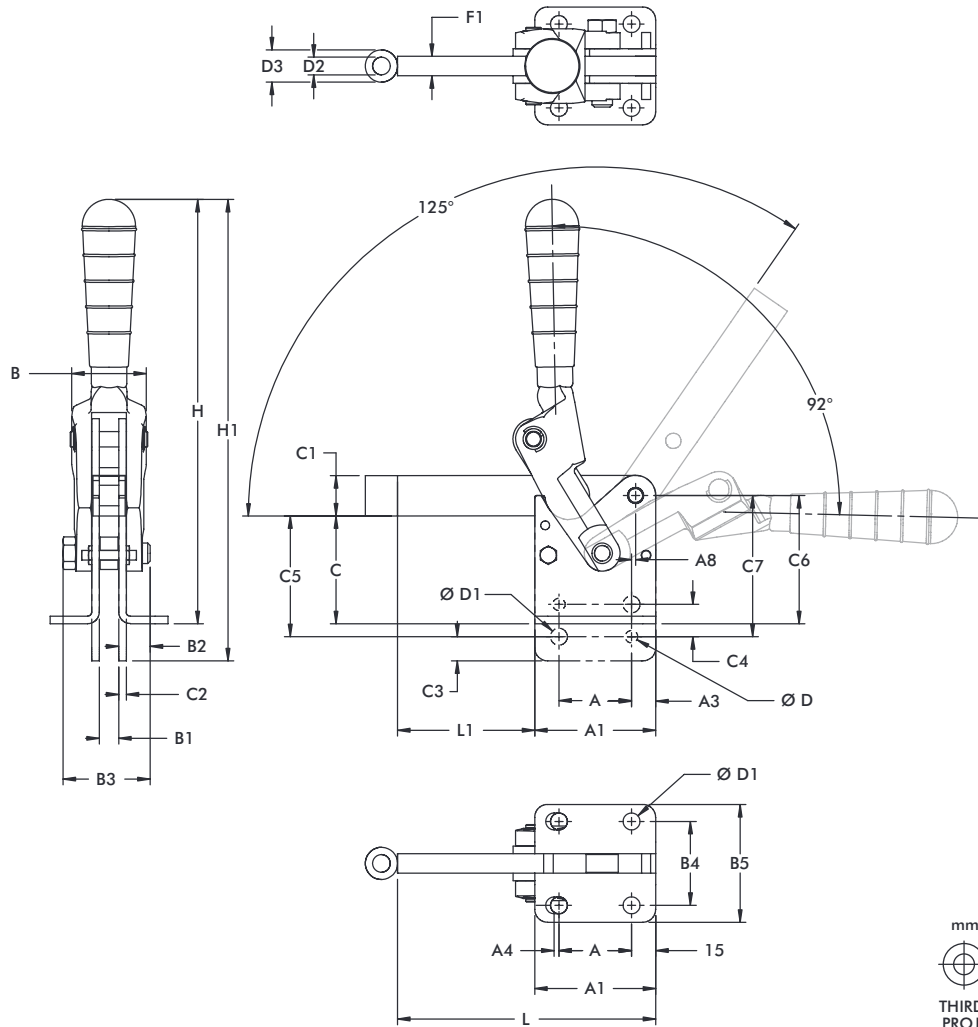

mm [INCH]  
THIRD ANGLE  
PROJECTION

Model	A	A1	A3	A4	A8	B	B1	B2	B3	B4	B5	C	C1	C2
533-L	[1.18] 30	[2.36] 59,9		[0.08] 2	[0.20] 5.1	[1.52] 38,6	[0.39] 9,9	[0.69] 15,5	[1.75] 44,5	[1.77] 45	[2.44] 62	[1.86] 47,2	[0.79] 20,1	
533-LB			[0.59] 15							--	--	--		[0.19] 4,8
535-L	[1.77] 45	[2.95] 74,9		--	[0.18] 4,6	[1.89] 48	[0.47] 11,9	[0.89] 22,6	[2.13] 54,1	[2.05] 52,1	[2.87] 72,9	[2.63] 66,8	[0.98] 24,9	
535-LB										--	--	--		

Model	C3	C4	C5	C6	C7	D	D1	D2	D3	F1	H	H1	L	L1
533-L	--	--	--	[2.24] 56,9	--	--	[0.33] 8,4	[0.35] 8,9	[0.59] 15	[0.39] 9,9	[8.6] 218,4	--	[4.92] 125	[2.56] 65
533-LB	[0.39] 9,9	[0.59] 15	[1.86] 55,1	--	[2.56] 65	[0.22] 5.6						[9.31] 236,5		
535-L	--	--	--	[3.13] 79,5	--	--	[0.41] 10,4	[0.43] 10,9	[0.79] 20,1	[0.47] 11,9	[10.35] 262,9	--	[6.30] 160	[3.35] 85,1
535-LB	[0.59] 15	[0.79] 20,1	[2.95] 74,9	--	[3.44] 87,4	[0.30] 7,6						[11.26] 286		

# 533, 535 SERIES

## Heavy-Duty Vertical Hold Down Clamps | Dimensions

**533-LBR**  
 Straight Base  
 Solid Bar  
 DESTACO®  
 Toggle Lock  
 Plus™

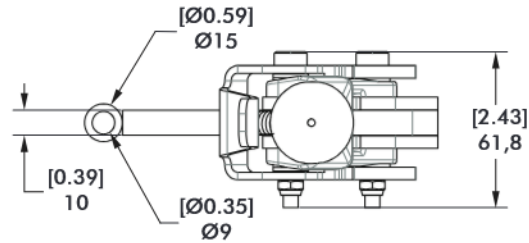

### DESTACO® TOGGLE LOCK PLUS OPTION

Secured in open  
 and closed position  
 against unintentional  
 opening up to 40 Nm.

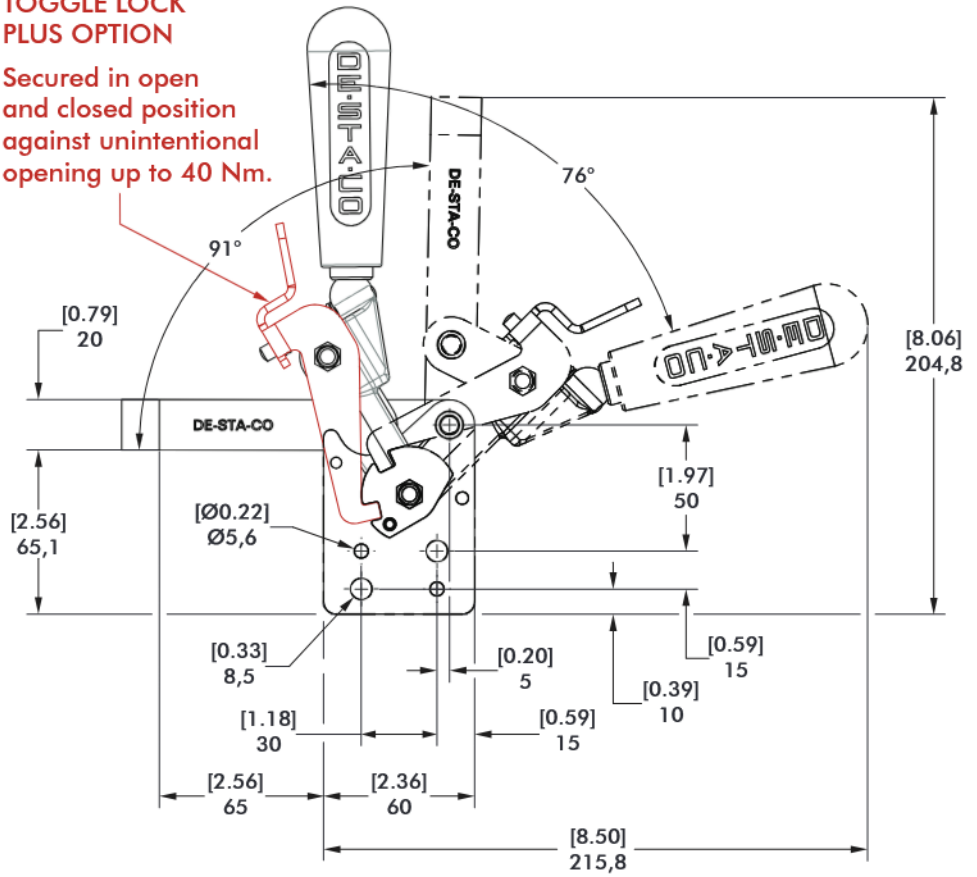
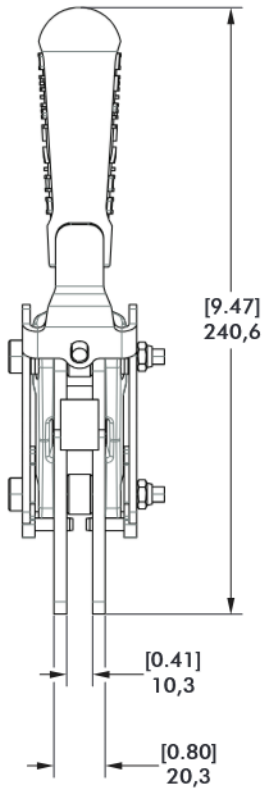

# 91090 SERIES

## Heavy-Duty Vertical Hold Down Clamps | Product Overview

### Features:

- Front flange mount
- Accepts M8 or 5/16" spindle accessory (not supplied)
- 5 handle colors - see page MC-PRO-7 for details

### Applications:

- Assembly & test
- Checking fixtures
- Light machining
- Woodworking

### Also Available:

See page MC-ACC-1 for accessories

91090  
Front Flanged Base  
Open Bar



**Color Handles**  
Available on models in this series that use standard red handles.\* Add -Y, -G, -B, -K to end of model number.

\*Excludes Blackout Series, Toggle Lock Plus levers or dipped handles.



## Technical Information | Dimensions

Model	Max. Holding Capacity	Clamp Bar Opening (+10°)	Handle Opening (+10°)	Weight	Recommended Accessories		
					Bolt Retainer	Spindle Assembly	Flanged Washers
91090	1710 N [385 lbf]	100°	60°	0,37 kg [0.81 lbs]	---	507208-M	507107

## Holding Forces

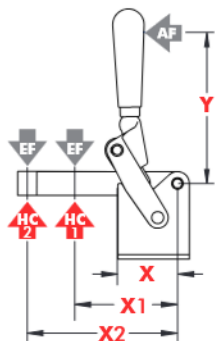

Model	X	X1	X2	Y	±HC1	±HC2	±EF(X1):AF	±EF(X2):AF
91090	[1.39] 35,3	[2.36] 60	[3.74] 95	[4.13] 105	[385 lbf] 1710 N	[240 lbf] 1065 N	8:1	5:1

Dimensions shown "mm [inch]" ± HC = Holding Capacity, EF = Exerting Force, AF = Applied Force  
See page MC-TEC-4 for additional information.

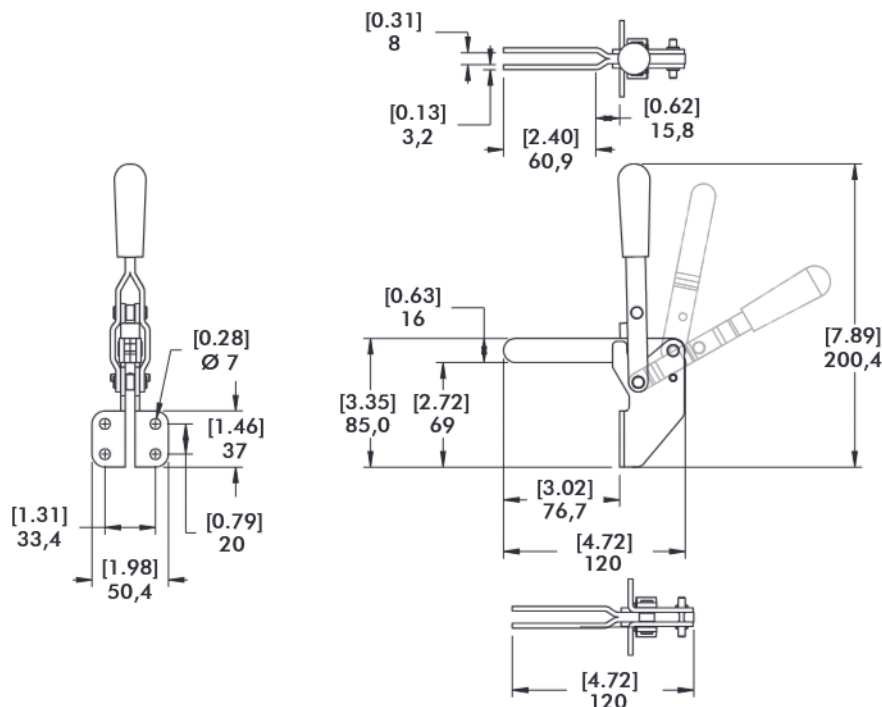

# 317 SERIES

## Vertical Hold Down Clamps | Product Overview

### Features:

- Dual mounting surfaces
- Large bar opening angle
- Accommodates M8 or 5/16" spindle accessories
- 5 handle colors - see page MC-PRO-7 for details

### Applications:

- Assembly & test
- Checking fixtures
- Light machining
- Woodworking

### Also Available:

See page MC-ACC-1 for accessories  
 817-U Pneumatic Toggle Clamp  
 (See page MC-PTC-19)  
 817-S Pneumatic Toggle Clamp  
 (See page MC-PTC-19)

**317-U**  
U-Bar



**317-S**  
Solid Bar



### Color Handles

Available on models in this series that use standard red handles.\*  
 Add -Y, -G, -B, -K to end of model number.

\*Excludes Blackout Series, Toggle Lock Plus levers or dipped handles.



## Technical Information

Model	Max. Holding Capacity	Clamp Bar Opening (+10°)	Handle Opening (+10°)	Weight	Accessories (Supplied)		
					Bolt Retainer	Spindle Assembly	Flanged Washers
317-U	1670 N [375 lbf]	185°	60°	[0.75 lbs] 0,34 kg	---	507208-M	507107
317-S	1780 N [400 lbf]				207105	---	---

## Holding Capacities

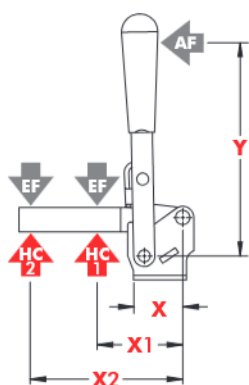

Model	X	X1	X2	Y	±HC1	±HC2	±EF(X1):AF	±EF(X2):AF
317-U	[1.57]	[2.00] 50,8	[3.75] 95,3	[4.00]	[375 lbf] 1670 N	[200 lbf] 900 N	17:1	8:1
317-S	40,0	[2.50] 63,5	[5.00] 127,0	101,6	[400 lbf] 1780 N	[190 lbf] 850 N	13:1	5:1

Dimensions shown "mm [inch]" ± HC = Holding Capacity, EF = Exerting Force, AF = Applied Force  
 See page MC-TEC-4 for additional information.

# 317 SERIES

## Vertical Hold Down Clamps | Dimensions

**317-U**  
U-Bar

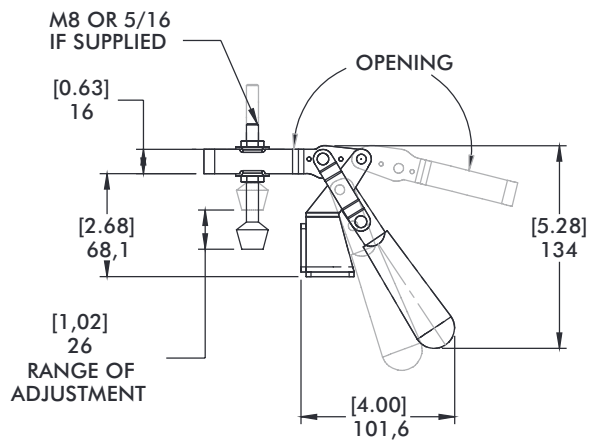
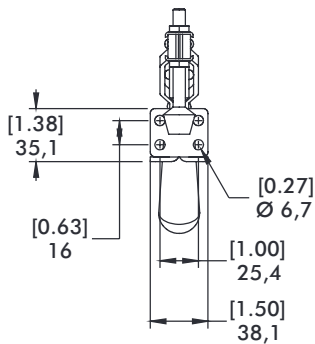
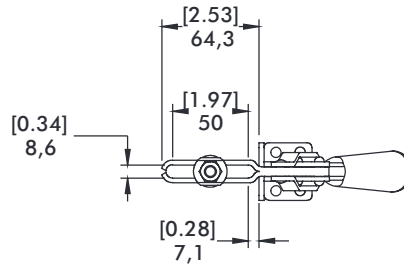

**317-S**  
Solid Bar

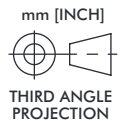
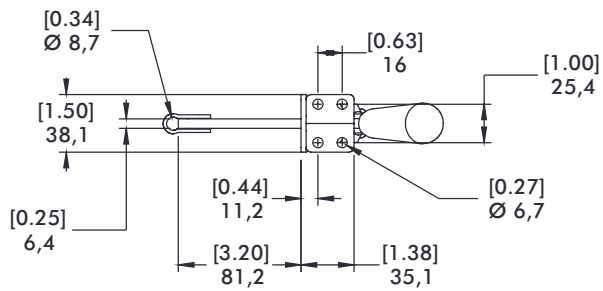

# 527 SERIES

## Vertical Hold Down Clamps | Product Overview

### Features:

- Hardened steel bushings at pivot points
- Solid bar can be modified to suit application requirements
- Thumb lever on link for easy opening

### Applications:

- Assembly & test
- Light machining
- Woodworking

527  
Flanged Base



527-F ⓘ  
Front Mount



## Technical Information

Model	Max. Holding Capacity	Clamp Bar Opening (+10°)	Handle Opening (+10°)	Weight
527	[1000 lbf] 4450 N	195°	65°	[2.50 lbs] 1,13 kg
527-F ⓘ				

ⓘ This item is available upon request

## Holding Capacities | Dimensions

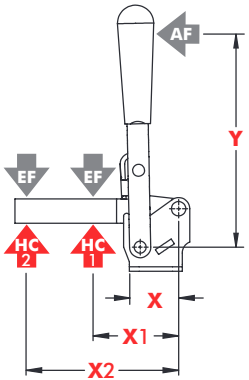

Model	X	X1	X2	Y	±HC1	±HC2	±EF(X1):AF	±EF(X2):AF
527	[3.12] 79,2	[3.50] 89,0	[6.00] 152,4	[4.00] 101,6	[1000 lbf] 4450 N	[580 lbf] 2580 N	23:1	12:1
527-F	[2.53] 64,3							

Dimensions shown "mm [inch]" ± HC = Holding Capacity, EF = Exerting Force, AF = Applied Force  
See page MC-TEC-4 for additional information.

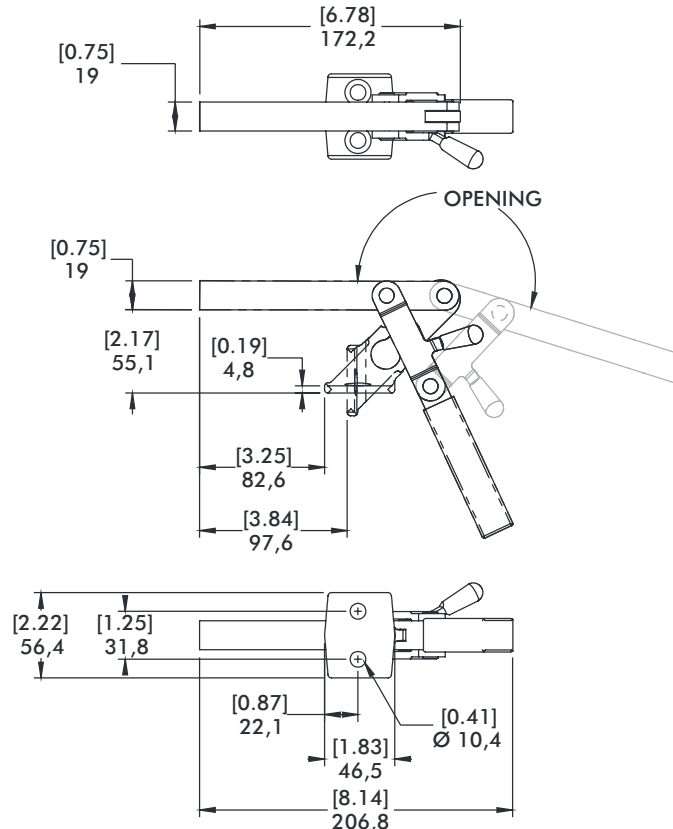
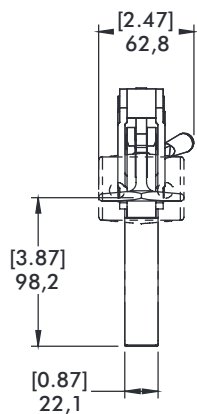

mm [INCH]  
THIRD ANGLE PROJECTION

# 7-101, 7-58, 7-59, 7-60 SERIES

## Heavy Duty Cam Action Series | Product Overview

### Features:

- Cam action accommodates variable workpiece thickness
- Heavy duty construction
- Solid clamp arms may be modified to suit application requirements

### Applications:

- Light machining
- Welding
- Assembly

7-101



7-58  
7-59  
7-60



### Technical Information

Model	Max. Holding Capacity	Clamp Bar Opening (+10°)	Weight
7-101	2110 N [475 lbf]	80°	0,45 kg [1.0 lbs]
7-58	2670 N [600 lbf]	95°	0,91 kg [2.0 lbs]
7-59	4450 N [1000 lbf]	95°	1,36 kg [3.0 lbs]
7-60	7120 N [1600 lbf]	80°	2,27 kg [5.0 lbs]

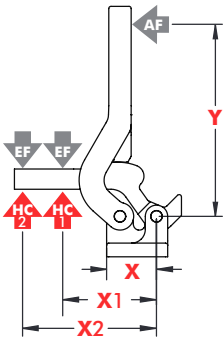

### Holding Forces | Dimensions

Model	X	X1	X2	Y	±HC1	±HC2	±EF(X1):AF	±EF(X2):AF
7-58	[1.38] 35.1	[2.36] 60	[3.54] 90	[5.31] 135	[600 lbf] 2670 N	[400 lbf] 1780 N	5:1	3:1
7-59	[1.69] 42.8	[3.46] 88	[4.72] 120	[6.69] 170	[1000 lbf] 4450 N	[725 lbf] 3225 N	4:1	3:1
7-60	[2.00] 50.8	[4.53] 115	[5.90] 150	[7.48] 190	[1600 lbf] 7120 N	[1225 lbf] 5450 N	4:1	3:1
7-101	[1.00] 25.4	[1.97] 50	[3.74] 95	[3.46] 88	[475 lbf] 2110 N	[250 lbf] 1110 N	1.50:1	1.25:1

Dimensions shown "mm [inch]" ± HC = Holding Capacity, EF = Exerting Force, AF = Applied Force  
See page MC-TEC-4 for additional information.

mm [INCH]  
THIRD ANGLE PROJECTION

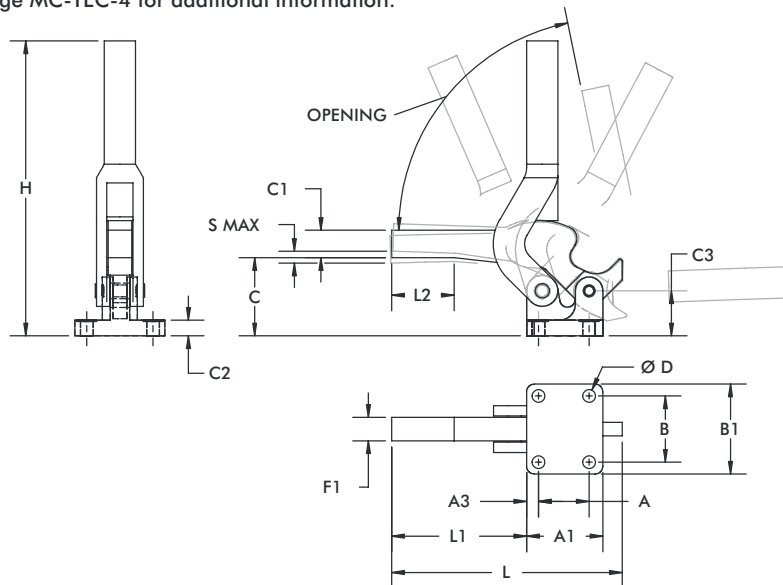

Model	A	A1	A3	B	B1	C	C1	C2	C3	D	F1	H	L	L1	L2	S max.
7-101	[0.75] 19,1	[1.25] 31,8	[0.25] 6,1	[1.25] 31,8	[1.75] 44,5	[1.44] 36,6	[0.50] 12,7	[0.31] 7,9	[1.00] 25,4	[0.22] 5,6	[0.50] 12,7	[5.00] 127	[4.62] 117,3	[3.12] 79,1	-	[0.13] 3,3
7-58	[1.00] 25,4	[1.69] 42,9	[0.34] 8,6	[1.62] 41,2	[2.25] 57,2	[1.87] 47,5	[0.56] 14,2	[0.38] 9,7	[1.12] 28,5	[0.28] 7,1	[0.50] 12,7	[6.93] 176	[4.62] 117,35	[2.55] 64,8	-	[0.13] 3,3
7-59	[1.38] 35,1	[2.06] 52,3	[0.39] 9,9	[1.88] 47,8	[2.50] 63,5	[2.19] 55,6	[0.63] 16	[0.44] 11,2	[1.25] 31,8	[0.34] 8,6	[0.63] 16	[8.50] 215,9	[6.00] 152,4	[3.45] 87,6	[1.24] 31,5	[0.19] 4,8
7-60	[1.62] 41,2	[2.44] 62	[0.44] 11,2	[2.12] 53,9	[2.88] 73,2	[2.50] 63,5	[0.88] 22,4	[0.50] 12,7	[1.44] 36,6	[0.41] 10,4	[0.75] 19,1	[9.44] 239,8	[7.38] 187,5	[4.32] 109,7	[1.97] 50	[0.25] 6,4



# 229 SERIES

## Vertical Hold Down Clamps | Product Overview

### Features:

- Cam action clamp holds workpieces of varying height
- Total clamping range of 8mm [0.31in.]
- Accommodates M12 or 1/2" accessories
- 5 handle colors - see page MC-PRO-7 for details

### Applications:

- Assembly & test
- Light machining
- Welding

### Also Available:

See page MC-ACC-1 for accessories

229  
Flanged Base  
Open Bar



### Color Handles

Available on models in this series that use standard red handles.\* Add -Y, -G, -B, -K to end of model number.

\*Excludes Blackout Series, Toggle Lock Plus levers or dipped handles.



## Technical Information

Model	Max. Holding Capacity	Clamp Bar Opening (+10°)	Handle Opening (+10°)	Weight	Accessories (Supplied)	
					Spindle Assembly	Flanged Washers
229	4450 N [1000 lbf]	115°	180°	1,17 kg [2.59 lbs]	229203	247109

## Holding Capacities

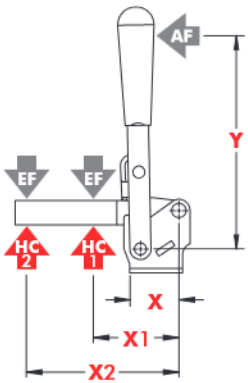

Model	X	X1	X2	Y	±HC1	±HC2	±EF(X1):AF	±EF(X2):AF
229	[1.53] 38,9	[3.00] 76,2	[6.12] 155,4	[7.06] 179,3	[1000 lbf] 4450 N	[500 lbf] 2230 N	7:1	3:1

Dimensions shown "mm [inch]" ± HC = Holding Capacity, EF = Exerting Force, AF = Applied Force  
See page MC-TEC-4 for additional information.

# 229 SERIES

## Vertical Hold Down Clamps | Dimensions

229  
Flanged Base  
Open Bar

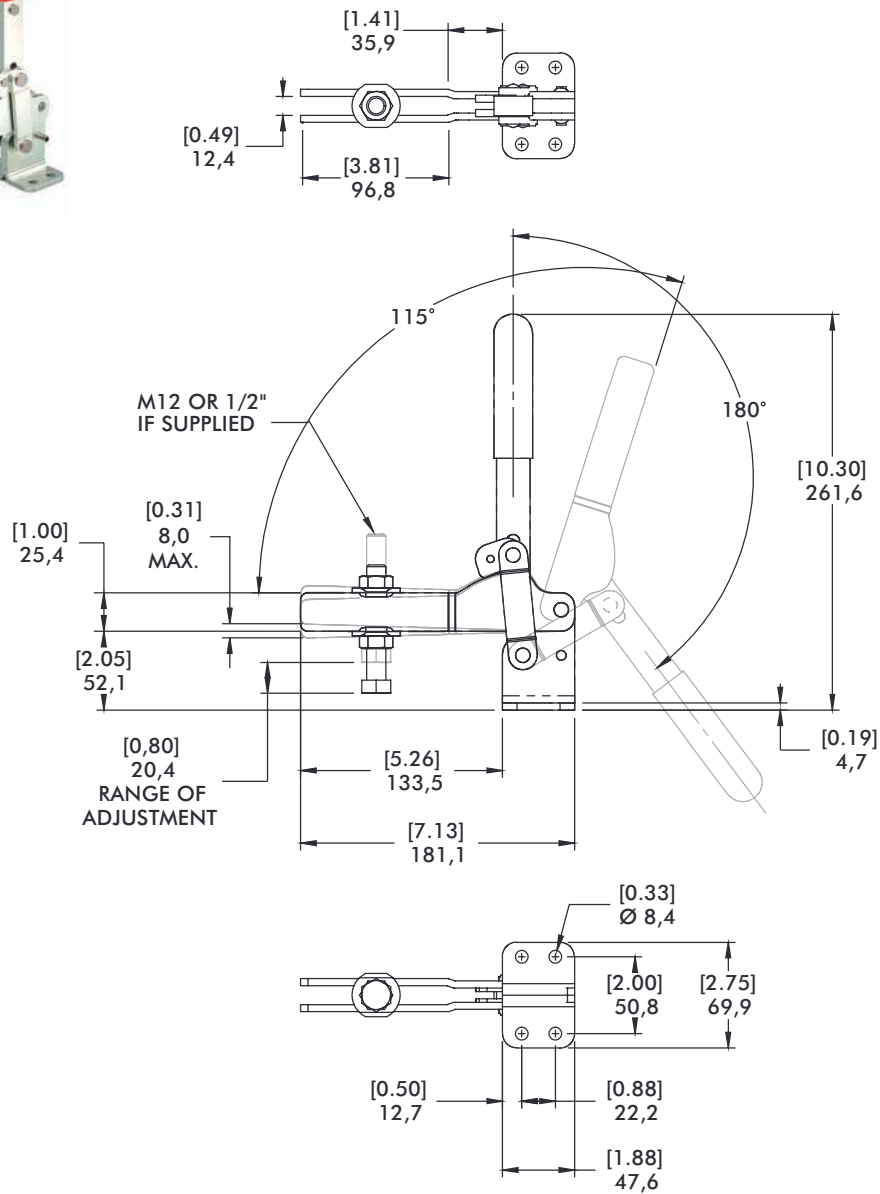

# 500 SERIES

## Weldable Vertical Hold Down Clamps | Product Overview

### Features:

- Hardened pivot pins and bushings
- Weldable clamping bar
- LSC version with locking spring clip for securing the handle in the open position
- DESTACO® Toggle Lock Plus™ (503-MLBR)
- Modular design allows you to set up the clamp to meet application requirements
- 5 handle colors (503-MLBR only) - see page MC-PRO-7 for details

### Applications:

- Welding
- Assembly
- Heavy duty, production clamping applications

### Also Available:

See page MC-VHD-47 for accessories

**503-MB**  
Swivel Base



**503-MLB**  
Long Base



**503-MLBR**  
Long Base,  
DESTACO®  
Toggle Lock  
Plus™



**503-MBLSC** ⓘ  
Swivel Base  
with Locking  
Spring Clip



**503-MLBLSC** ⓘ  
Long Base  
with Locking  
Spring Clip



**505-MB**  
Swivel Base



**505-MLB**  
Long Base



**505-MBLSC** ⓘ  
Swivel Base  
with Locking  
Spring Clip



**505-MLBLSC** ⓘ  
Long Base  
with Locking  
Spring Clip



**506-MB**  
Swivel Base



**506-MLB** ⓘ  
Long Base



**506-MBLSC** ⓘ  
Swivel Base  
with Locking  
Spring Clip



**506-MLBLSC** ⓘ  
Long Base  
with Locking  
Spring Clip



Model 505-MLB in a robotic welding fixture

ⓘ This item is available upon request

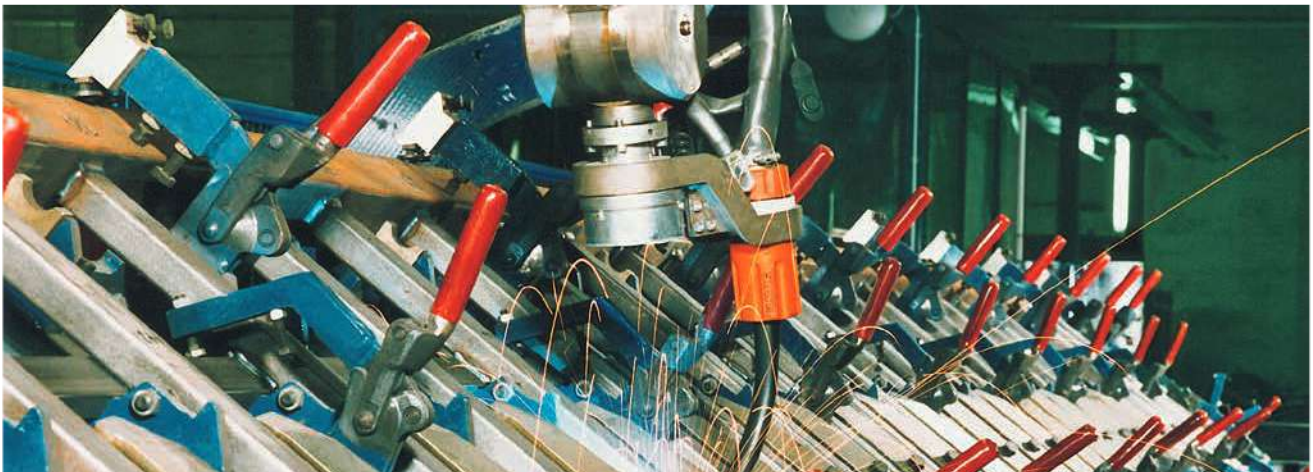

Model	Max. Holding Capacity	Clamp Bar Opening (+10°)	Weight
503-MB	[1575 lbf] 7000 N	200°	0,70 kg [1.54 lbs]
503-MLB			0,80 kg [1.76 lbs]
503-MLBR		90°	1,26 kg [2.78 lbs]
503-MBLSC ⓘ			0,80 kg [1.76 lbs]
503-MLBLSC ⓘ			0,90 kg [1.98 lbs]
505-MB	[2475 lbf] 11000 N	200°	1,40 kg [3.09 lbs]
505-MLB			1,50 kg [3.31 lbs]
505-MBLSC ⓘ			1,60 kg [3.53 lbs]
505-MLBLSC ⓘ			1,60 kg [3.53 lbs]
506-MB	[5060 lbf] 22500 N		2,60 kg [5.73 lbs]
506-MLB ⓘ			2,80 kg [6.17 lbs]
506-MBLSC ⓘ			2,80 kg [6.17 lbs]
506-MLBLSC ⓘ			3,00 kg [6.61 lbs]

**Note:**

The clamping bars are made from forged alloy steel and must be heated to 200°C (400°F) prior to welding. We recommend welding the handles, clamp arms, and mounting bases when disassembled. Welding of non pre-heated parts may only be done with the addition of welding fillers.

ⓘ This item is available upon request

Clamping Position

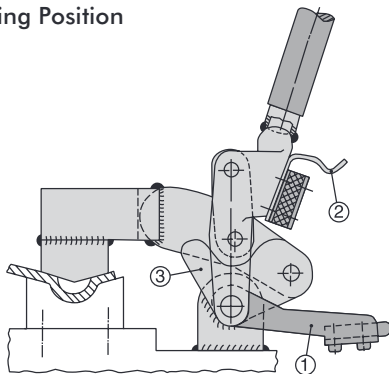

- Patented spring latch hold-open device
1. Mount the clamp and place it in the closed position
  2. Position the bracket in the leaf spring

Open Position

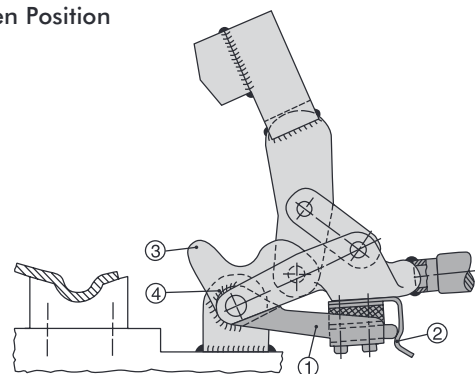

3. Swivel the clamp into the open position
4. In this position, weld the bracket with the bar guide feature at point

# 500 SERIES

## Weldable Vertical Hold Down Clamps | Dimensions | -B/-LB/-MB/-MLB/-MBLSC/-MLBLSC

### Swivel Base

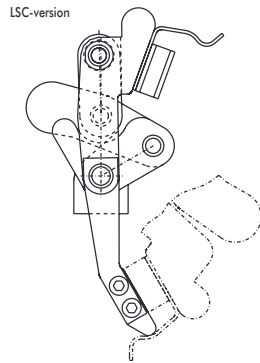
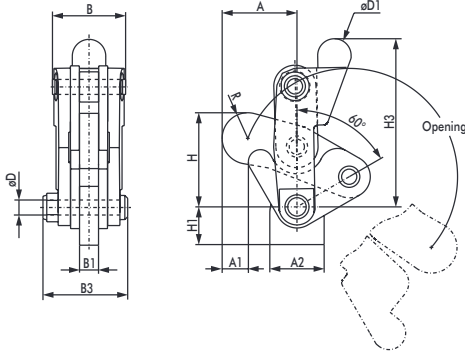

**503-MB**  
Swivel Base



### Long Base

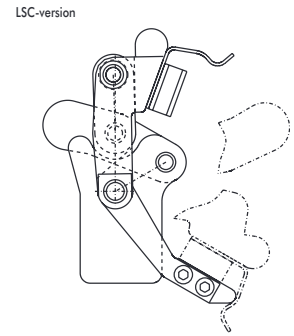
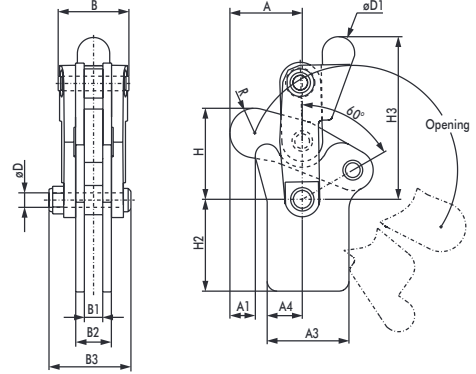

**503-MLB**  
Long Base



### Swivel Base Dimensions

Model	A	A1	A2	B	B1	B3	ØD	ØD1	H	H1	H3	R
503-MB	[1.54]	[0.50]	[1.12]	[1.52]	[0.39]	[1.82]	[0.31]	[0.69]	[1.96]	[0.79]	[3.51]	[0.53]
503-MBLSC ⓘ	39,2	12,8	28,5	38,5	10	46,2	8	17,5	49,8	20	89,1	13,5
505-MB	[2.22]	[1.02]	[1.38]	[1.89]	[0.48]	[2.31]	[0.37]	[0.87]	[2.79]	[1.10]	[4.33]	[0.72]
505-MBLSC ⓘ	56,5	25,9	35	48	12,3	58,6	9,5	22,2	70,8	28	110,1	18,3
506-MB	[2.82]	[1.27]	[1.97]	[1.91]	[0.63]	[2.72]	[0.47]	[0.94]	[3.45]	[1.29]	[5.30]	[0.84]
506-MBLSC ⓘ	71,7	32,3	50	48,4	16	69	12	24	87,7	32,8	134,6	21,4

### Long Base Dimensions

Model	A	A1	A3	A4	B	B1	B2	B3	ØD	ØD1	H	H2	H3	R
503-MLB	[1.54]		[1.75]	[0.75]	[1.52]	[0.39]	[0.79]	[1.82]	[0.31]	[0.69]	[1.96]	[1.97]	[3.51]	[0.53]
503-MLBLSC ⓘ	39,2		44,5	19	38,5	10	20	46,2	8	17,5	49,8	50	89,1	13,5
505-MLB	[2.22]	[1.02]	[2.09]	[1.08]	[1.89]	[0.48]	[0.88]	[2.31]	[0.37]	[0.87]	[2.79]	[2.50]	[4.33]	[0.72]
505-MLBLSC ⓘ	56,5	25,9	53	27,5	48	12,3	22,3	58,6	9,5	22,2	70,8	63,5	110,1	18,3
506-MLB	[2.82]	[1.27]	[2.58]	[1.45]	[1.91]	[0.63]	[1.10]	[2.72]	[0.47]	[0.94]	[3.45]	[3.00]	[5.30]	[0.84]
506-MLBLSC ⓘ	71,7	32,3	65,5	36,9	48,4	16	28	69	12	24	87,7	76,2	134,6	21,4

### Long Base with DESTACO® Toggle Lock Plus

#### DESTACO® TOGGLE LOCK PLUS OPTION

Secured in open  
and closed position  
against unintentional  
opening up to 40 Nm.

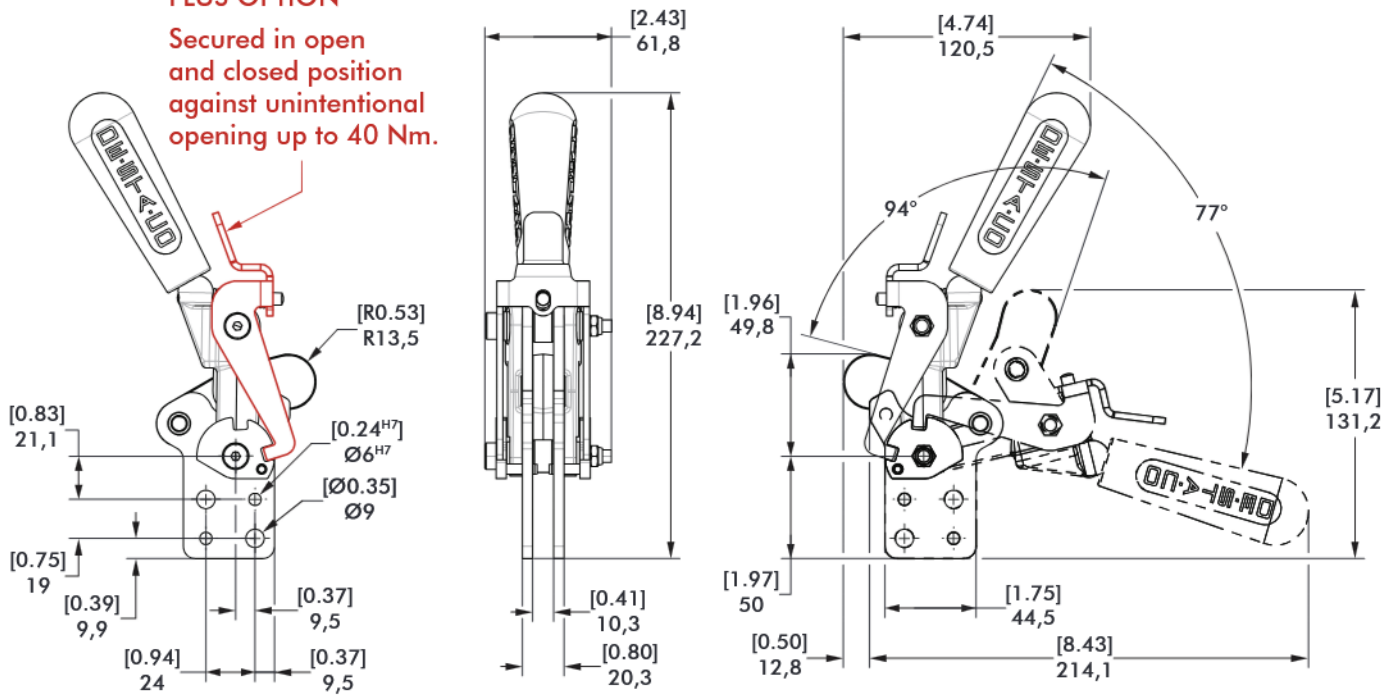

**503-MLBR**  
Long Base,  
DESTACO®  
Toggle Lock  
Plus™



**Color Handles**  
Available on this model.  
Add -Y, -G, -B, -K to  
end of model number.



# 500 SERIES

## Weldable Vertical Hold Down Clamps | Accessories

### Features:

- Used with 500 Series Vertical Clamps
- Allows you to customize the clamp to suit application requirements

### Applications:

- Welding
- Assembly
- Heavy duty, production clamping applications

### Also Available:

See page MC-VHD-43 for clamp linkage

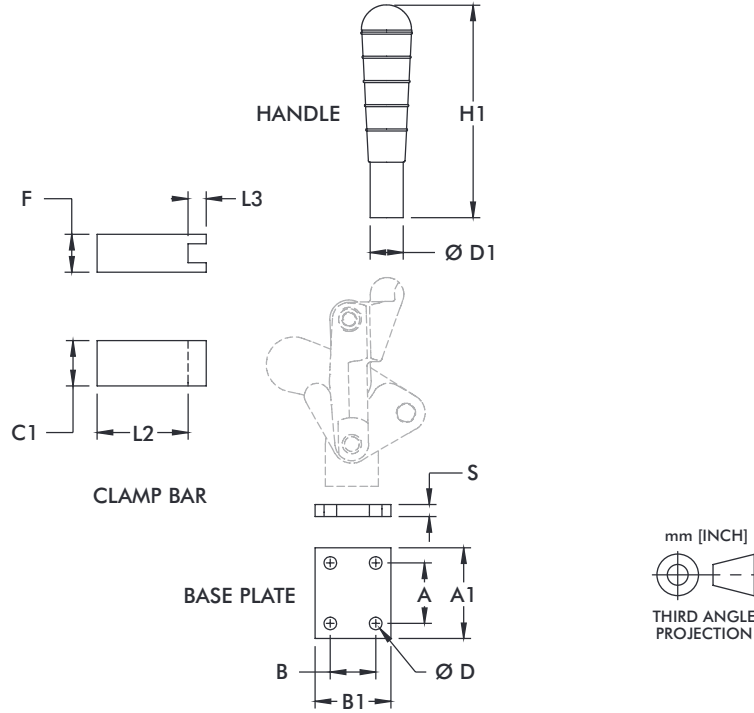

Use with	Part No.	Handle*		Clamping Bar				Base Plate					
		ØD1	H1	C1	F	L2	L3	A	A1	B	B1	ØD	S
503	503503-L	Ø18	129.5	-	-	-	-	-	-	-	-	-	-
	503501	-	-	25	20	50	8	-	-	-	-	-	-
	503502	-	-	-	-	-	-	25	40	35	50	6.3	8
505	505503-L	Ø22	159	-	-	-	-	-	-	-	-	-	-
	505501	-	-	30	25	60	12	-	-	-	-	-	-
	505502	-	-	-	-	-	-	40	60	30	50	8.1	8
506	506503-L	Ø28	188	-	-	-	-	-	-	-	-	-	-
	506501	-	-	35	30	75	15	-	-	-	-	-	-
	506502	-	-	-	-	-	-	50	70	45	65	8.1	8

\*Handle comes standard on 503-MLBR. Note: Dimensions shown in millimeters.

