

# 812 SERIES

## Pneumatic Toggle Clamps | Product Overview

### Features:

- Smallest of the pneumatic hold down series
- Pneumatic version of Model 201-U

### Applications:

- Assembly
- Welding

### Also Available:

See page MC-ACC-1 for spindle accessories

See page MC-PSC-38 for sensing options

High temperature version available upon request as Model 812-**U-HT**

### 812-U



## Technical Information | Holding Capacities

Model	Maximum Holding Capacity		Maximum Exerting Force @ 5 bar [72 PSI]		Weight	Bore Size	Air Consumption† dm <sup>3</sup> [ft <sup>3</sup> ]	Port Size	Accessories (Supplied)	
	Inner	Outer	Inner	Outer					Spindle Accessory	Flanged Washers
812-U	[100 lbf] 440 N	[55 lbf] 245 N	[136 lbf] 613 N	[92 lbf] 413 N	[0.46 lbs] 0,21 kg	[0.75] 19,1	[0.003] 0,09	M5	305208-M	102111

†Per double stroke at 5 bar [72 PSI]

**Max. Operating Temp:** -23°C to 74°C [-10°F to 165°F]

**Optional Sensors:** 810156, 810158

**Replacement Clamp Assembly:** 812-U-LC

**Replacement Cylinder Assembly:** 812CYL

In no case should the inlet pressure be high enough to create an exerting force that exceeds the clamp's holding capacity.

See Technical Appendix Section for details.

# 812 SERIES

Pneumatic Toggle Clamps | Dimensions | -U

812-U

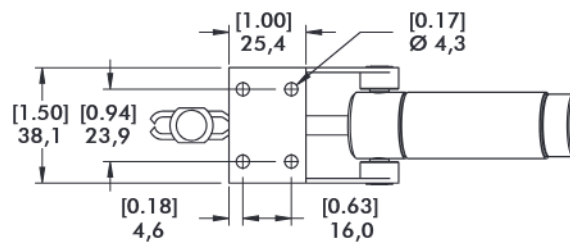
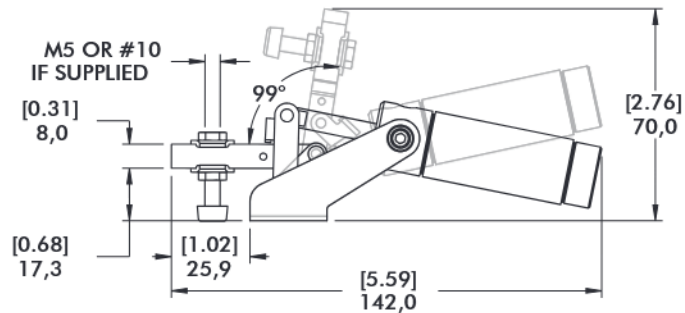
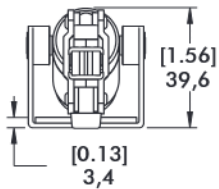
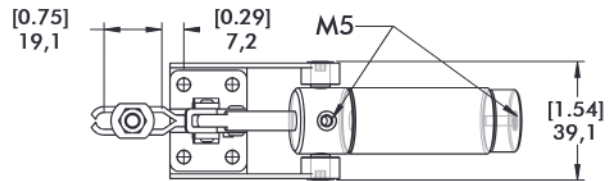

**Note:**

Model 812-U requires either 810156 or 810158 sensors. Two (2) sensors are required if detecting both open and closed positions. These sensors use 810156-1 (included with sensors) band clamp to mount the sensor to the cylinder wall.

