

RTH SERIES

3-Jaw Parallel Grippers | Features and Benefits | How To Order

Features:

- Rugged multi-purpose powerful gripper
- 8 sizes for small lightweight to very large and heavy part gripping
- High impact resistant with triple wedge design
- Shielded gripper to repel metal chips/particulates
- Spring assist option maintains grip in case of air pressure loss
- Purge and scavenge ports for harsh & clean environments
- Multi-position sensing up to 3 locations

Applications:

- Large round shaped parts
- Automotive engine block and gantry systems
- Ideal for very heavy part gripping

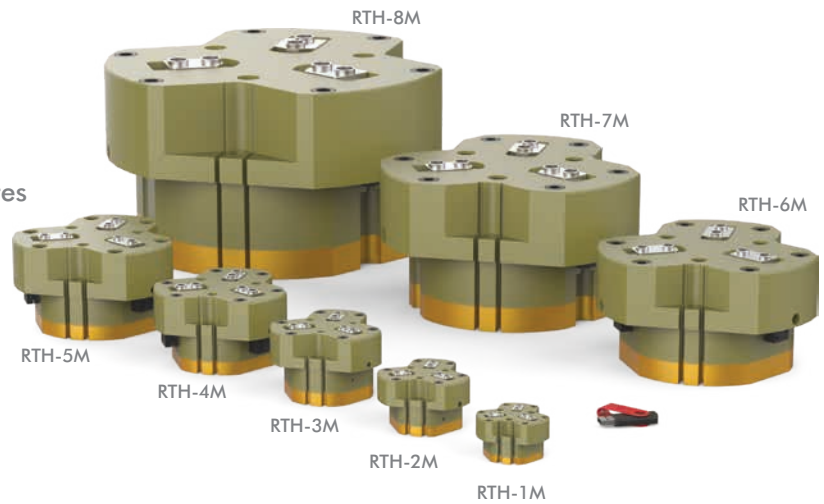

(USB key shown for scale)

How To Order

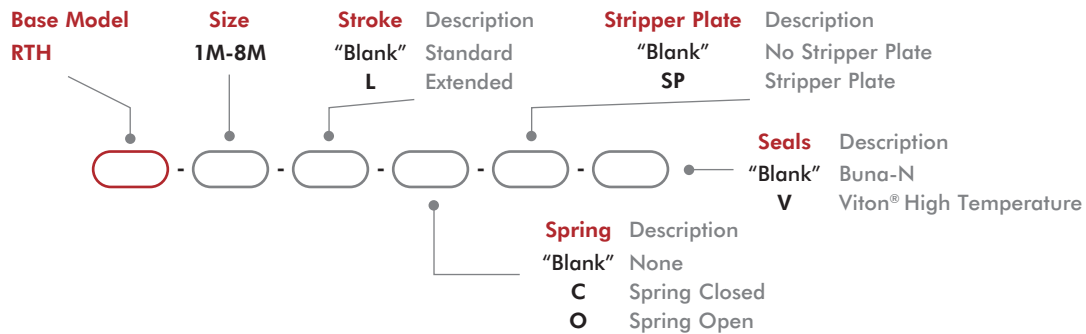

Accessories

Sensor Accessories	Model Numbers	Part Number	Qty/Unit
8mm PNP Magneto Resistive Sensor (90° barrel) w/ M8 Qk. Disc*	All Models	OHSP-011	1-3 [†]
8mm NPN Magneto Resistive Sensor (90° barrel) w/ M8 Qk. Disc*	All Models	OHSN-011	1-3 [†]
8mm PNP Magneto Resistive Sensor Short Barrel w/ M8 Qk Disc*	All Models	OHSP-017	1-3 [†]
8mm NPN Magneto Resistive Sensor Short Barrel w/ M8 Qk Disc*	All Models	OHSN-017	1-3 [†]
8mm PNP Inductive Sensor w/ M8 Quick Disconnect*	RTH-4M, -5M, -6M	OISP-011	1-3
8mm NPN Inductive Sensor w/ M8 Quick Disconnect*	RTH-4M, -5M, -6M	OISN-011	1-3
12mm PNP Inductive Sensor w/ M12 Quick Disconnect*	RTH-7M, -8M	OISP-017	1-3
12mm NPN Inductive Sensor w/ M12 Quick Disconnect*	RTH-7M, -8M	OISN-017	1-3
M8 Quick Disconnect 2 Meter Cable Length*	All Models	CABL-010	1-3
M8 Quick Disconnect 5 Meter Cable Length*	All Models	CABL-013	1-3
M12 Quick Disconnect 2 Meter Cable Length*	RTH-7M, -8M	CABL-014	1-3 [†]
M12 Quick Disconnect 5 Meter Cable Length*	RTH-7M, -8M	CABL-018	1-3 [†]

Pneumatic Accessories	Model Numbers	Part Number	Qty/Unit
M5 Adjustable Flow Control	RTH-1M, -2M, -3M	VLVF-008	1-2
G 1/8" 90° Adjustable Flow Control	RTH-4M, -5M, -6M, -7M	VLVF-005	1-2
G 1/4" Adjustable Flow Control	RDH-8M	VLVF-010	1-2

* Sensor and cable sold separately. [†]Except RTH-1, 1-2 only.

3-Jaw Heavy-Duty Parallel Grippers | Technical Specifications

Specifications	Units	1M	1M-L	2M	2M-L	3M	3M-L	4M	4M-L
Total Rated Grip Force F @ 100 psi [7 bar] w/o Spring Assist	N [lbs]	682 [153]	443 [100]	1238 [278]	812 [183]	2078 [467]	1349 [303]	3644 [819]	2366 [532]
Total Rated Grip Force F @ 100 psi [7 bar] with Spring Assist	N [lbs]	889 [200]	579 [130]	1490 [335]	979 [220]	2627 [591]	1708 [384]	4562 [1026]	2967 [667]
Total Stroke	mm [in]	4 [0.16]	8 [0.32]	6 [0.24]	12 [0.47]	8 [0.31]	16 [0.63]	10 [0.39]	20 [0.79]
Weight	kg [lbs]	0.25 [0.6]		0.53 [1.2]		1.08 [2.4]		1.95 [4.3]	
Pressure Range w/o Spring	bar [psi]	2-7 [30-100]							
Pressure Range with Spring	bar [psi]	4-7 [60-100]				3.5-7 [50-100]		3-7 [45-100]	
Max. Vacuum for Scavenge Port	mm Hg [in Hg]	200 [8]							
Max. Pressure for Purge Port	bar [psi]	2.1 [30]							
Ingress Protection Class (IP)		IP55							
Displacement	cm ³ [in ³]	6.5 [0.40]		17 [1.05]		37 [2.30]		80 [4.90]	
Temperature Range (Buna-N seals)	°C [°F]	-35°~80° [-30°~180°]							
Temperature Range (Viton® seals)	°C [°F]	-30°~150° [-20°~300°]							
Actuation (open/close)	sec.	0.06		0.07		0.08		0.1	
Accuracy	mm [in]	±0.04 [±0.002]						±0.06 [±0.0024]	
Repeatability	mm [in]	±0.02 [±0.001]						±0.03 [±0.0012]	
Valve to Actuate Single Acting		3-way, 2-position							
Valve to Actuate Double Acting		4-way, 2-position							

Specifications (cont.)	Units	5M	5M-L	6M	6M-L	7M	7M-L	8M	8M-L
Total Rated Grip Force F @ 100 psi [7 bar] w/o Spring Assist	N [lbs]	6353 [1428]	4125 [927]	10202 [2294]	6629 [1490]	17165 [3859]	11102 [2496]	35288 [7933]	22784 [5122]
Total Rated Grip Force F @ 100 psi [7 bar] with Spring Assist	N [lbs]	7877 [1771]	5124 [1152]	13786 [3099]	8971 [2017]	22093 [4967]	14322 [3222]	44354 [9971]	28690 [6450]
Total Stroke	mm [in]	13 [0.51]	26 [1.02]	16 [0.63]	32 [1.26]	25 [0.98]	50 [1.97]	35 [1.38]	70 [2.76]
Weight	kg [lbs]	3.9 [8.6]		7.89 [17.4]		15.7 [34.6]		43.9 [96.8]	
Pressure Range w/o Spring	bar [psi]	2-7 [30-100]							
Pressure Range with Spring	bar [psi]	3-7 [45-100]		4-7 [55-100]				3.5-7 [50-100]	
Max. Vacuum for Scavenge Port	mm Hg [in Hg]	20 [8]							
Max. Pressure for Purge Port	bar [psi]	2.1 [30]							
Ingress Protection Class (IP)		IP55							
Displacement	cm ³ [in ³]	180 [11.0]		355 [22]		940 [57]		2720 [166]	
Temperature Range (Buna-N seals)	°C [°F]	-35°~80° [-30°~180°]							
Temperature Range (Viton® seals)	°C [°F]	-30°~150° [-20°~300°]							
Actuation (open/close)	sec.	0.19		0.236		0.85		1.7	
Accuracy	mm [in]	±0.06 [±0.0024]		±0.08 [±0.0031]				±0.1 [±0.0039]	
Repeatability	mm [in]	±0.03 [±0.0012]		±0.04 [±0.0016]				±0.05 [±0.002]	
Valve to Actuate Single Acting		3-way, 2-position							
Valve to Actuate Double Acting		4-way, 2-position							

RTH-1M, -1M-L

3-Jaw Parallel Grippers | Dimensions and Technical Specifications

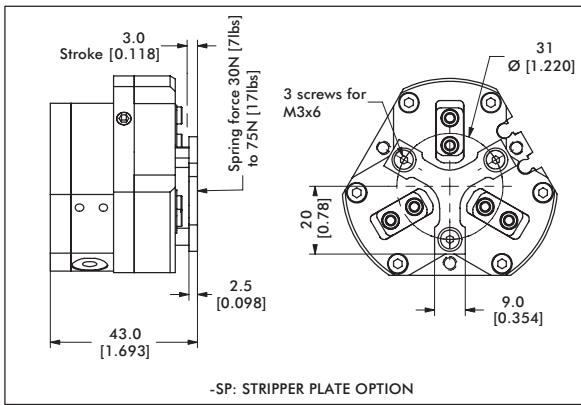
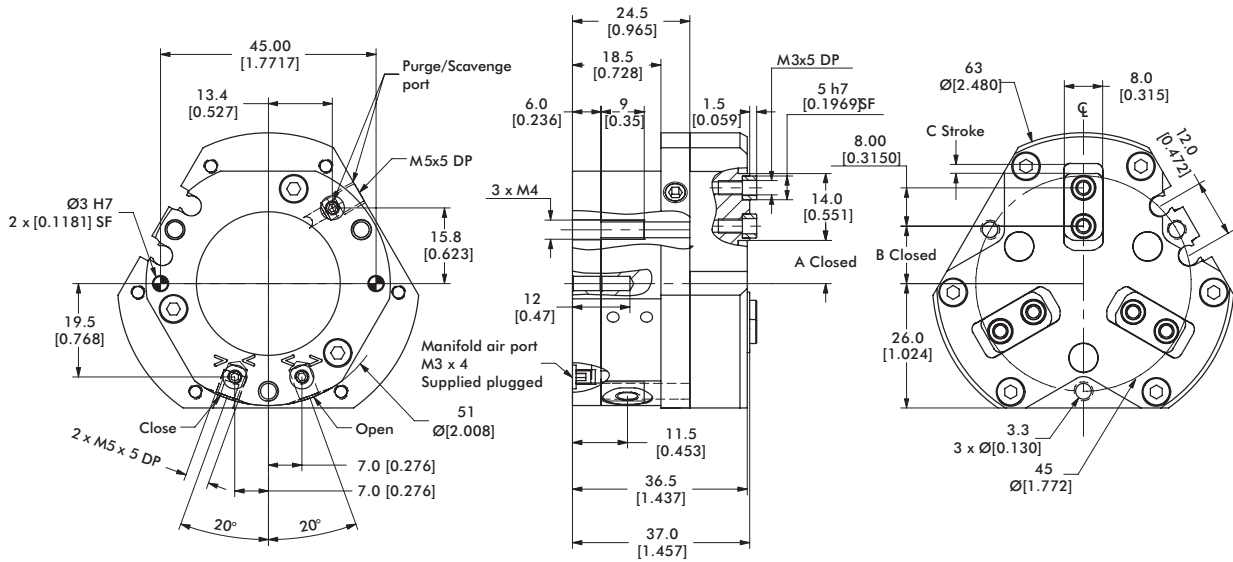

mm [INCH]
THIRD ANGLE PROJECTION

Model	A	B	C
RTH-1M	9.0 [0.354]	12.0 [0.472]	2.0 [0.08]
RTH-1M-L	7.0 [0.276]	10.0 [0.394]	4.1 [0.16]

Dimensions in mm [in]

Seal Repair Kits	RTH-1M
Buna-N Seal Repair Kit	SLKT-347
Buna-N Rear Inlet Seal Repair Kit	SLKT-363
Viton® Seal Repair Kit	SLKT-347V
Viton® Rear Inlet Seal Repair Kit	SLKT-363V

Loading Information

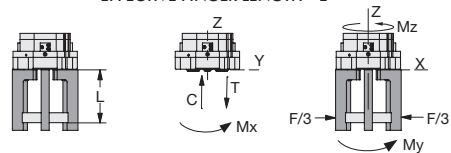
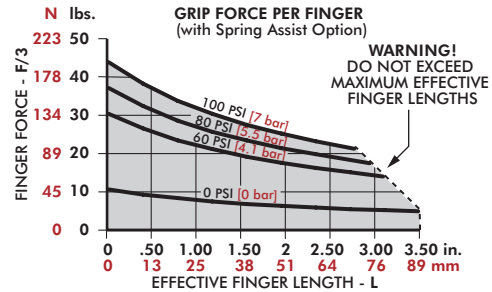
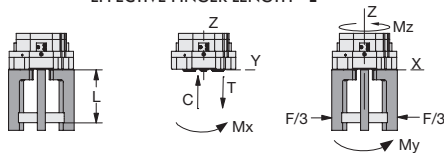
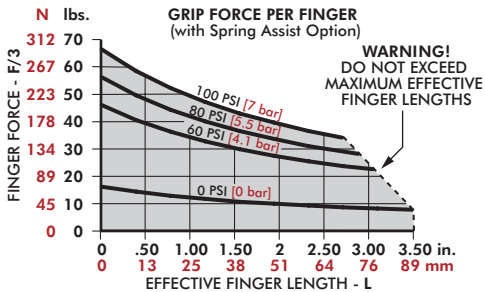

RTH-1M	Static	Dynamic
Maximum Tensile T	810 N [182 lbs]	89 N [20 lbs]
Maximum Compressive C	1060 N [238 lbs]	89 N [20 lbs]
Maximum Moment M_x	22 Nm [195 in-lbs]	2 Nm [18 in-lbs]
Maximum Moment M_y	28 Nm [248 in-lbs]	3 Nm [27 in-lbs]
Maximum Moment M_z	18 Nm [159 in-lbs]	3 Nm [27 in-lbs]

*Capacities are per set of jaws and are not simultaneous

RTH-1M-L	Static	Dynamic
Maximum Tensile T	730 N [164 lbs]	57 N [13 lbs]
Maximum Compressive C	960 N [216 lbs]	57 N [13 lbs]
Maximum Moment M_x	20 Nm [177 in-lbs]	1 Nm [9 in-lbs]
Maximum Moment M_y	23 Nm [204 in-lbs]	1 Nm [9 in-lbs]
Maximum Moment M_z	15 Nm [133 in-lbs]	1 Nm [9 in-lbs]

*Capacities are per set of jaws and are not simultaneous

RTH-2M, -2M-L

3-Jaw Parallel Grippers | Dimensions and Technical Specifications

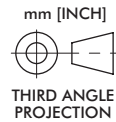
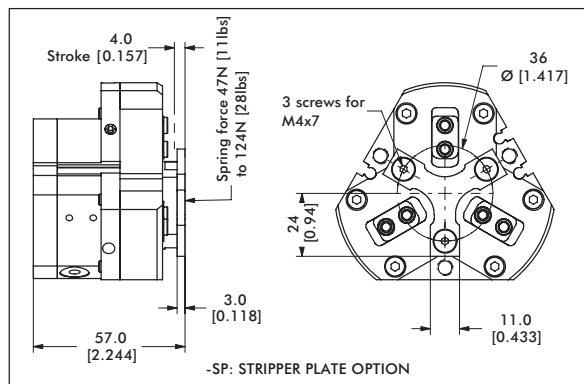
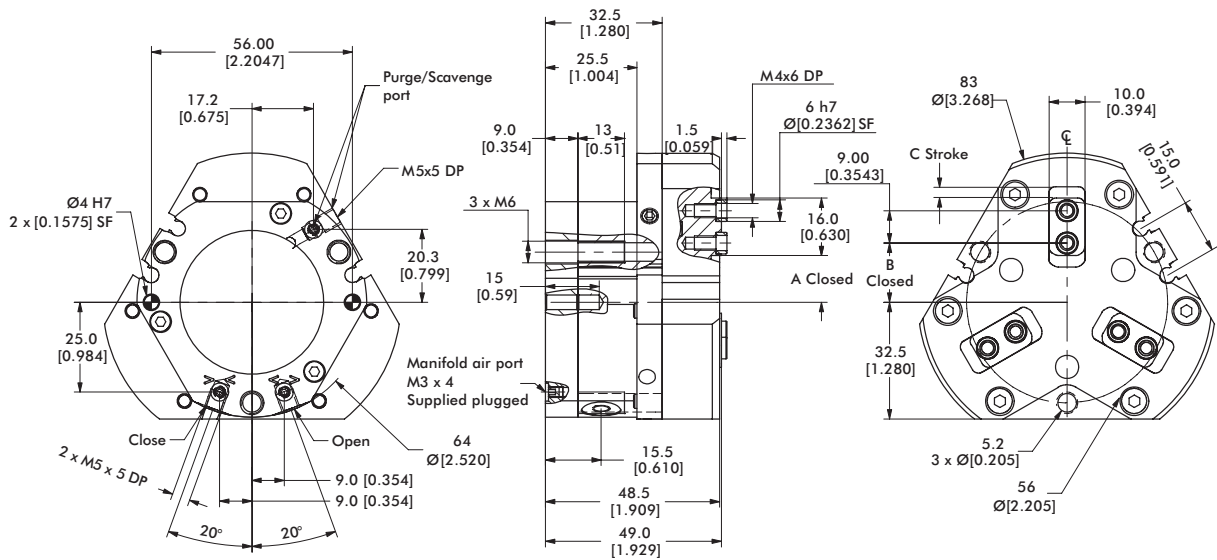

Model	A	B	C
RTH-2M	13.0 [0.512]	16.5 [0.650]	3.0 [0.12]
RTH-2M-L	10.0 [0.394]	13.5 [0.531]	6.0 [0.24]

Dimensions in mm [in]

Seal Repair Kits	RTH-2M
Buna-N Seal Repair Kit	SLKT-348
Buna-N Rear Inlet Seal Repair Kit	SLKT-363
Viton® Seal Repair Kit	SLKT-4348V
Viton® Rear Inlet Seal Repair Kit	SLKT-363V

Loading Information

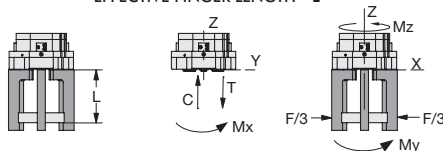
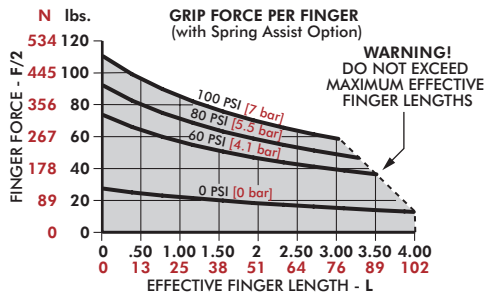

RTH-2M	Static	Dynamic
Maximum Tensile T	1200 N [270 lbs]	129 N [29 lbs]
Maximum Compressive C	1560 N [351 lbs]	129 N [29 lbs]
Maximum Moment M_x	45 Nm [398 in-lbs]	4 Nm [35 in-lbs]
Maximum Moment M_y	64 Nm [566 in-lbs]	6 Nm [53 in-lbs]
Maximum Moment M_z	41 Nm [363 in-lbs]	6 Nm [53 in-lbs]

*Capacities are per set of jaws and are not simultaneous

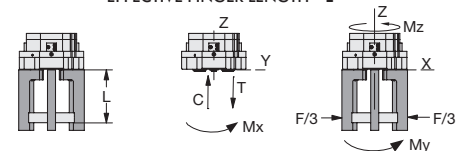
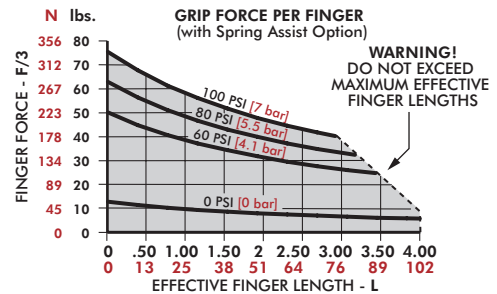

RTH-2M-L	Static	Dynamic
Maximum Tensile T	1080 N [243 lbs]	84 N [19 lbs]
Maximum Compressive C	1400 N [315 lbs]	84 N [19 lbs]
Maximum Moment M_x	40 Nm [354 in-lbs]	3 Nm [27 in-lbs]
Maximum Moment M_y	52 Nm [460 in-lbs]	4 Nm [35 in-lbs]
Maximum Moment M_z	33 Nm [292 in-lbs]	4 Nm [35 in-lbs]

*Capacities are per set of jaws and are not simultaneous

RTH-3M, -3M-L

3-Jaw Parallel Grippers | Dimensions and Technical Specifications

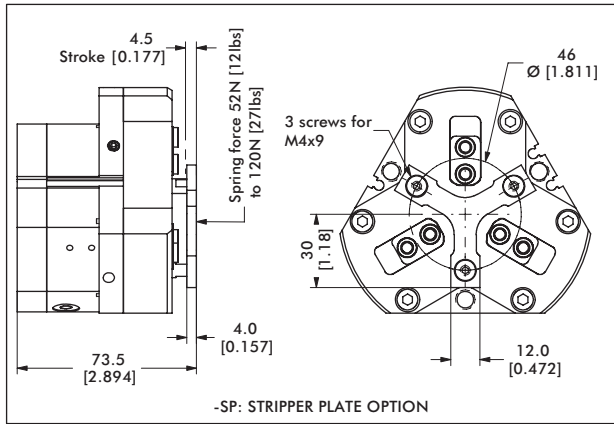
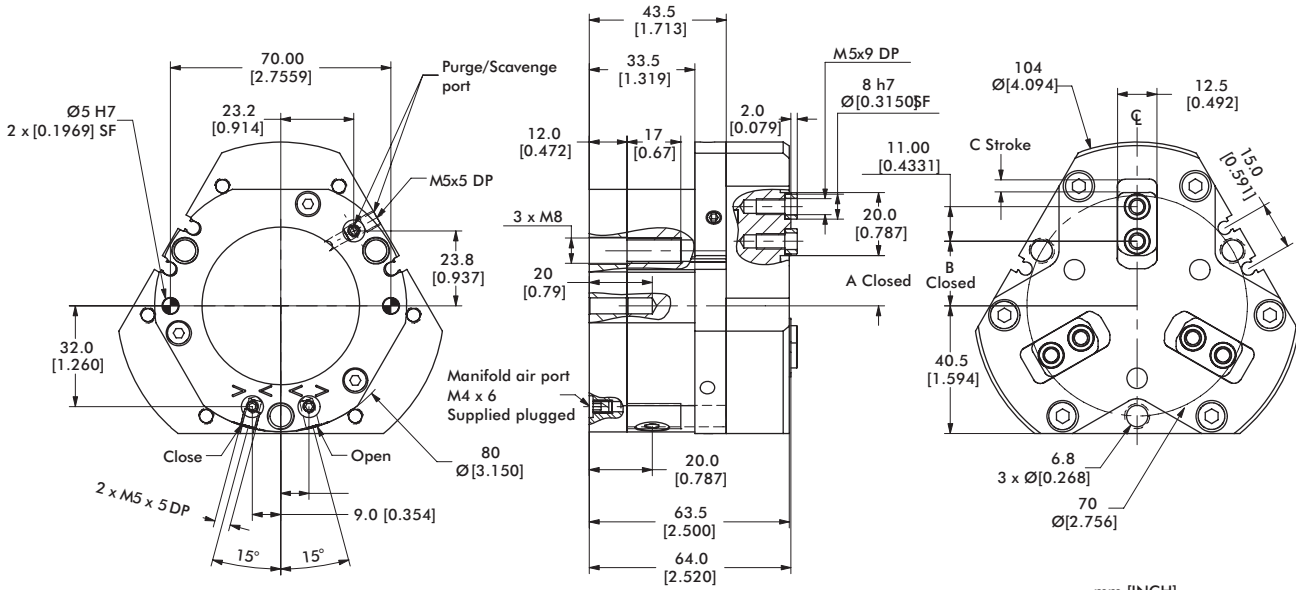

mm [INCH]

 THIRD ANGLE PROJECTION

Model	A	B	C
RTH-3M	16.0 [0.630]	20.5 [0.807]	3.9 [0.16]
RTH-3M-L	12.0 [0.742]	16.5 [0.650]	8.0 [0.32]

Dimensions in mm [in]

Seal Repair Kits	RTH-3M
Buna-N Seal Repair Kit	SLKT-349
Buna-N Rear Inlet Seal Repair Kit	SLKT-364
Viton® Seal Repair Kit	SLKT-349V
Viton® Rear Inlet Seal Repair Kit	SLKT-364V

Loading Information

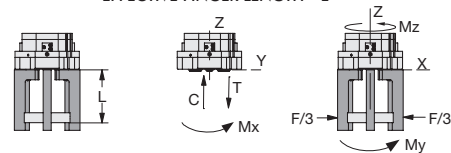
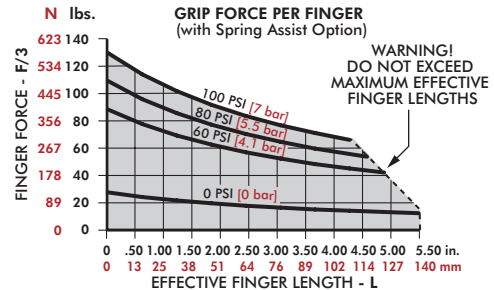
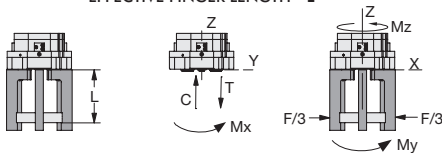
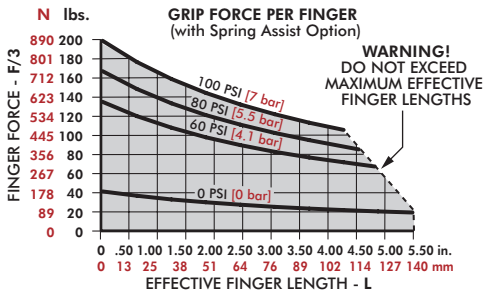

RTH-3M	Static	Dynamic
Maximum Tensile T	1680 N [378 lbs]	302 N [68 lbs]
Maximum Compressive C	2180 N [490 lbs]	302 N [68 lbs]
Maximum Moment M_x	72 Nm [637 in-lbs]	11 Nm [97 in-lbs]
Maximum Moment M_y	102 Nm [903 in-lbs]	16 Nm [142 in-lbs]
Maximum Moment M_z	66 Nm [584 in-lbs]	16 Nm [142 in-lbs]

[†]Capacities are per set of jaws and are not simultaneous

RTH-3M-L	Static	Dynamic
Maximum Tensile T	1500 N [337 lbs]	197 N [44 lbs]
Maximum Compressive C	1940 N [436 lbs]	197 N [44 lbs]
Maximum Moment M_x	64 Nm [566 in-lbs]	7 Nm [62 in-lbs]
Maximum Moment M_y	81 Nm [717 in-lbs]	9 Nm [80 in-lbs]
Maximum Moment M_z	53 Nm [469 in-lbs]	9 Nm [80 in-lbs]

[†]Capacities are per set of jaws and are not simultaneous

RTH-4M, -4M-L

3-Jaw Parallel Grippers | Dimensions and Technical Specifications

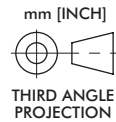
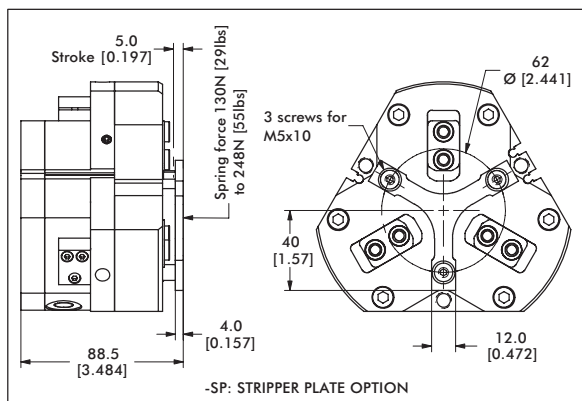
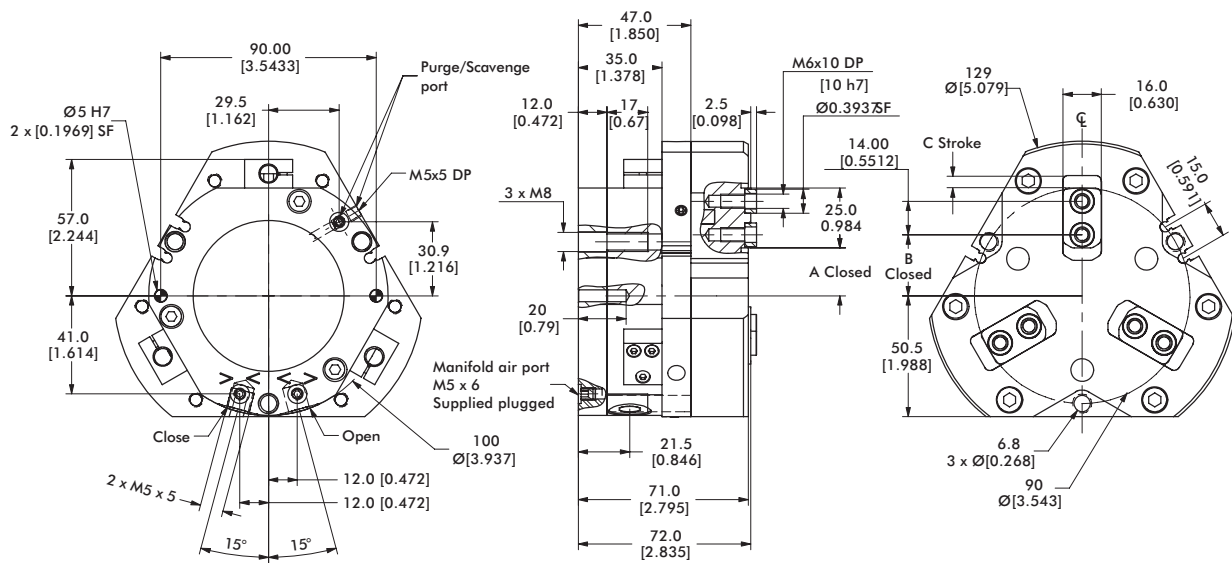

Model	A	B	C
RTH-4M	20.0 [0.787]	25.5 [1.004]	5.0 [0.20]
RTH-4M-L	15.0 [0.591]	20.5 [0.807]	10.0 [0.40]

Dimensions in mm [in]

Seal Repair Kits	RTH-4M
Buna-N Seal Repair Kit	SLKT-350
Buna-N Rear Inlet Seal Repair Kit	SLKT-365
Viton® Seal Repair Kit	SLKT-350V
Viton® Rear Inlet Seal Repair Kit	SLKT-365V

Loading Information

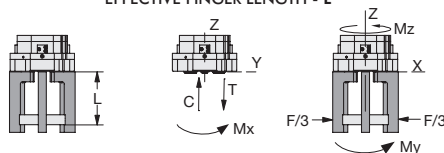
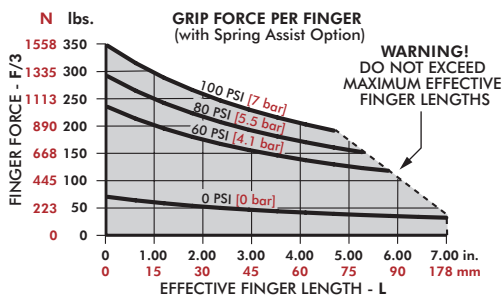

RTH-4M	Static	Dynamic
Maximum Tensile T	2110 N [474 lbs]	425 N [96 lbs]
Maximum Compressive C	2790 N [627 lbs]	425 N [96 lbs]
Maximum Moment M_x	92 Nm [814 in-lbs]	16 Nm [142 in-lbs]
Maximum Moment M_y	182 Nm [1133 in-lbs]	22 Nm [195 in-lbs]
Maximum Moment M_z	84 Nm [734 in-lbs]	22 Nm [195 in-lbs]

*Capacities are per set of jaws and are not simultaneous

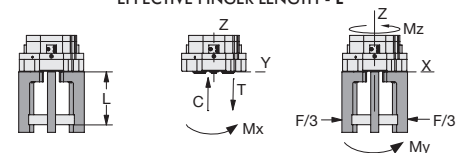
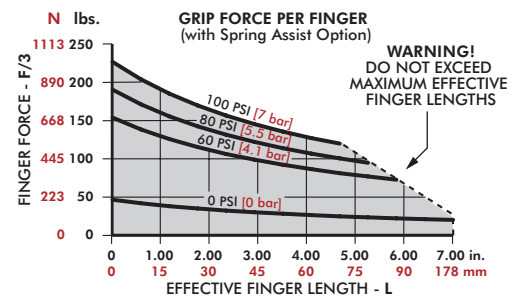

RTH-4M-L	Static	Dynamic
Maximum Tensile T	1880 N [423 lbs]	275 N [62 lbs]
Maximum Compressive C	2490 N [560 lbs]	275 N [62 lbs]
Maximum Moment M_x	82 Nm [726 in-lbs]	10 Nm [89 in-lbs]
Maximum Moment M_y	102 Nm [903 in-lbs]	13 Nm [115 in-lbs]
Maximum Moment M_z	67 Nm [593 in-lbs]	13 Nm [115 in-lbs]

*Capacities are per set of jaws and are not simultaneous

RTH-5M, -5M-L

3-Jaw Parallel Grippers | Dimensions and Technical Specifications

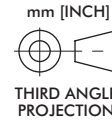
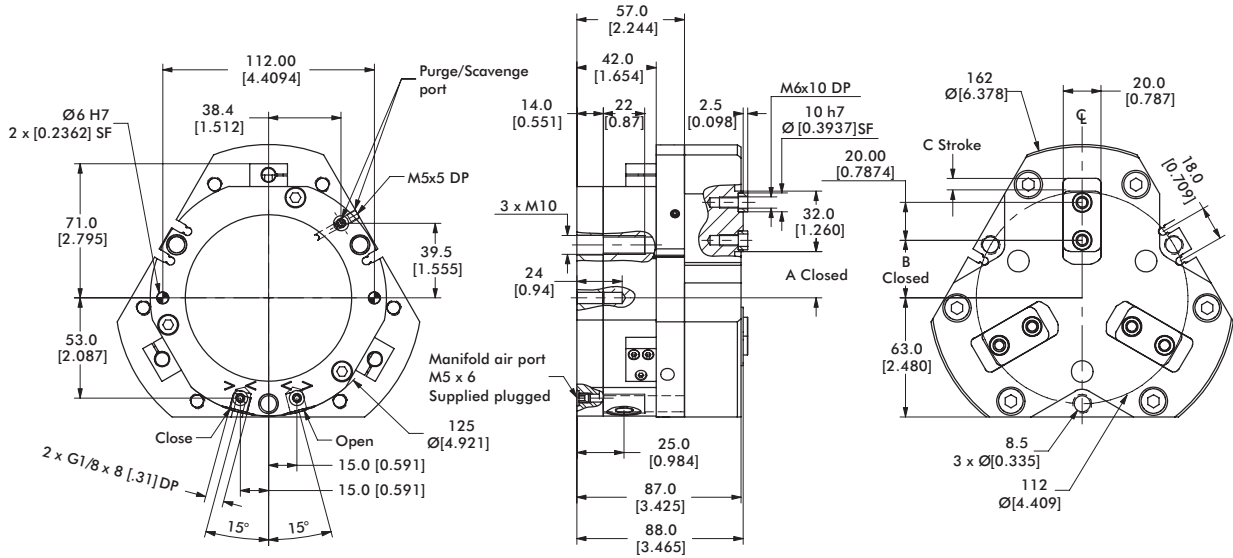

Model	A	B	C
RTH-5M	24.5 [0.965]	30.5 [1.201]	6.5 [0.26]
RTH-5M-L	18.0 [0.709]	24.0 [0.945]	13.0 [0.51]

Dimensions in mm [in]

Seal Repair Kits	RTH-5 M
Buna-N Seal Repair Kit	SLKT-351
Buna-N Rear Inlet Seal Repair Kit	SLKT-365
Viton® Seal Repair Kit	SLKT-351V
Viton® Rear Inlet Seal Repair Kit	SLKT-365V

Loading Information

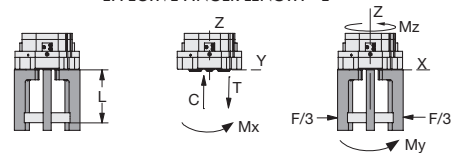
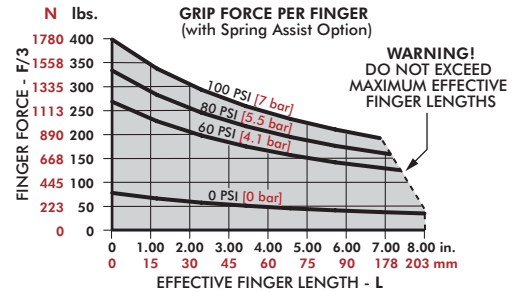
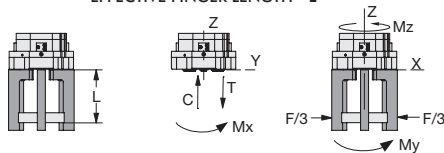
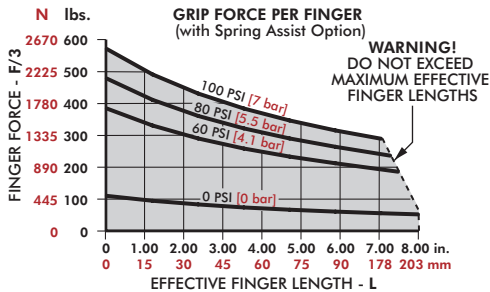

RTH-5M	Static	Dynamic
Maximum Tensile T	2990 N [672 lbs]	674 N [152 lbs]
Maximum Compressive C	3980 N [895 lbs]	674 N [152 lbs]
Maximum Moment M_x	127 Nm [1124 in-lbs]	25 Nm [221 in-lbs]
Maximum Moment M_y	179 Nm [1584 in-lbs]	35 Nm [310 in-lbs]
Maximum Moment M_z	117 Nm [1036 in-lbs]	35 Nm [310 in-lbs]

*Capacities are per set of jaws and are not simultaneous

RTH-5M-L	Static	Dynamic
Maximum Tensile T	2680 N [602 lbs]	432 N [97 lbs]
Maximum Compressive C	3570 N [803 lbs]	432 N [97 lbs]
Maximum Moment M_x	114 Nm [1009 in-lbs]	16 Nm [142 in-lbs]
Maximum Moment M_y	144 Nm [1275 in-lbs]	20 Nm [177 in-lbs]
Maximum Moment M_z	94 Nm [832 in-lbs]	20 Nm [177 in-lbs]

*Capacities are per set of jaws and are not simultaneous

RTH-6M, -6M-L

3-Jaw Parallel Grippers | Dimensions and Technical Specifications

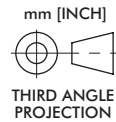
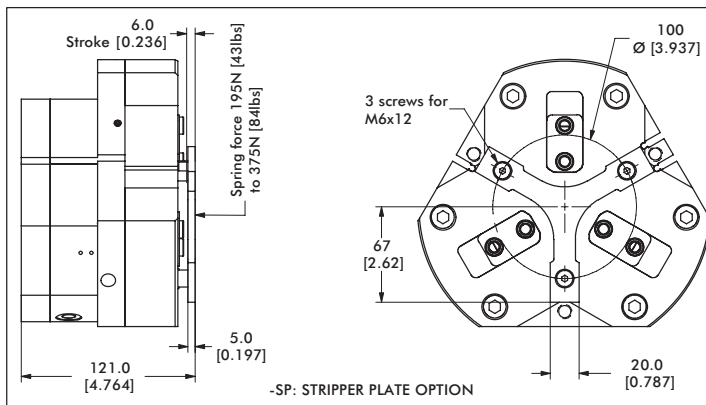
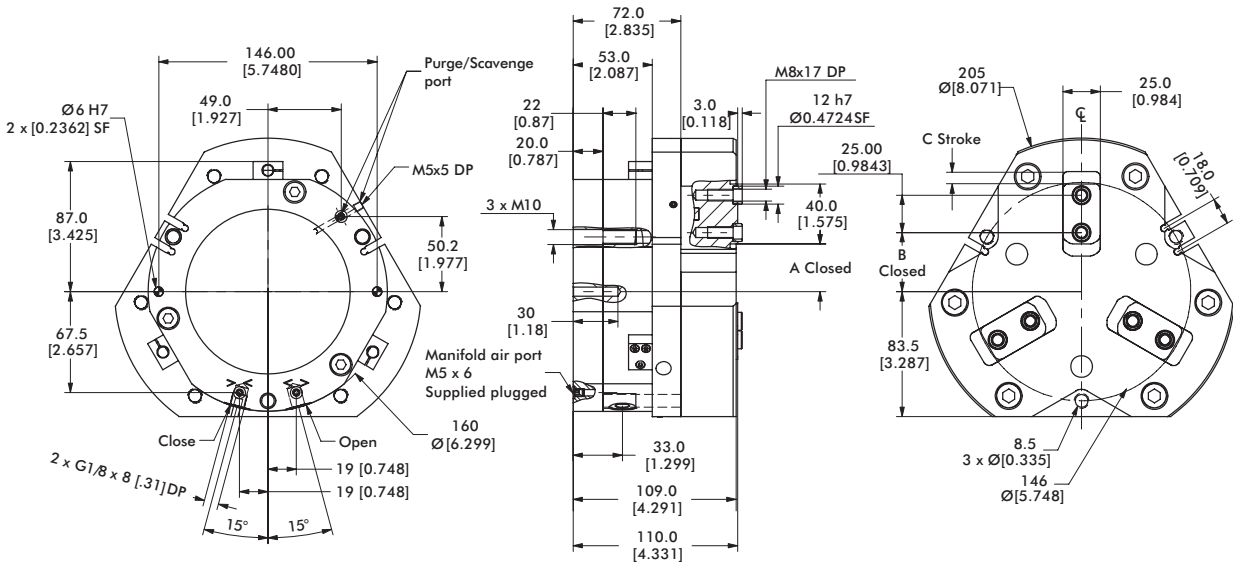

Model	A	B	C
RTH-6M	32.0 [1.260]	39.5 [1.555]	8.0 [0.32]
RTH-6M-L	24.0 [0.945]	31.5 [1.240]	16.0 [0.63]

Dimensions in mm [in]

Seal Repair Kits	RTH-6M
Buna-N Seal Repair Kit	SLKT-352
Buna-N Rear Inlet Seal Repair Kit	SLKT-365
Viton® Seal Repair Kit	SLKT-352V
Viton® Rear Inlet Seal Repair Kit	SLKT-365V

Loading Information

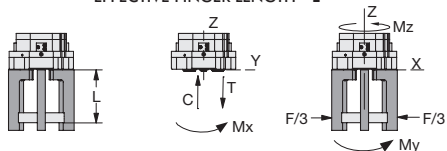
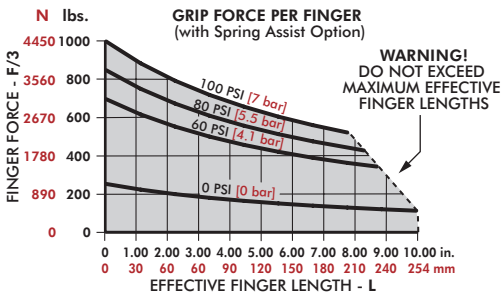

RTH-6M	Static	Dynamic
Maximum Tensile T	4320 N [971 lbs]	1315 N [296 lbs]
Maximum Compressive C	5810 N [1306 lbs]	1315 N [296 lbs]
Maximum Moment M _x	172 Nm [1522 in-lbs]	45 Nm [398 in-lbs]
Maximum Moment M _y	250 Nm [2213 in-lbs]	65 Nm [575 in-lbs]
Maximum Moment M _z	164 Nm [1452 in-lbs]	65 Nm [575 in-lbs]

*Capacities are per set of jaws and are not simultaneous

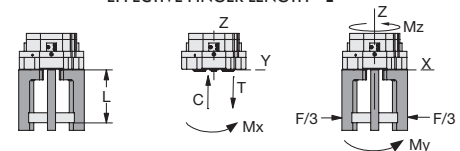
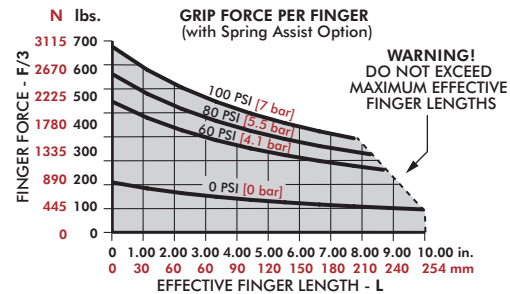

RTH-6M-L	Static	Dynamic
Maximum Tensile T	3860 N [868 lbs]	852 N [192 lbs]
Maximum Compressive C	5180 N [1165 lbs]	852 N [192 lbs]
Maximum Moment M _x	154 Nm [1363 in-lbs]	29 Nm [257 in-lbs]
Maximum Moment M _y	199 Nm [1761 in-lbs]	37 Nm [327 in-lbs]
Maximum Moment M _z	131 Nm [1159 in-lbs]	37 Nm [327 in-lbs]

*Capacities are per set of jaws and are not simultaneous

RTH-7M, -7M-L

3-Jaw Parallel Grippers | Dimensions and Technical Specifications

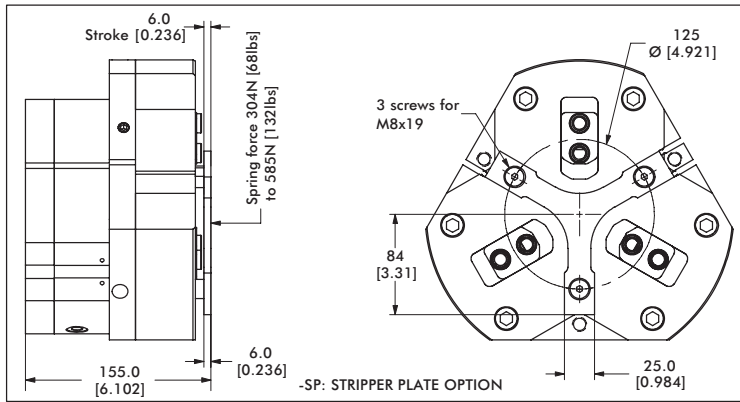
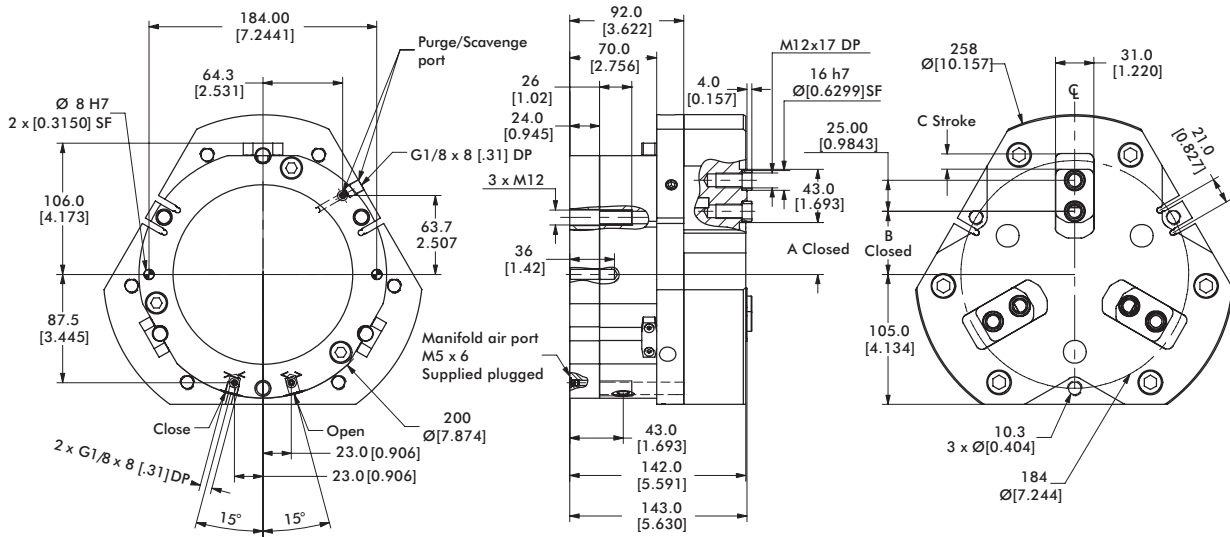

mm [INCH]
THIRD ANGLE PROJECTION

Model	A	B	C
RTH-7M	42.0 [1.654]	51.0 [2.008]	12.4 [0.49]
RTH-7M-L	29.5 [1.161]	38.5 [1.516]	25.0 [0.99]

Dimensions in mm [in]

Seal Repair Kits	RTH-7M
Buna-N Seal Repair Kit	SLKT-353
Buna-N Rear Inlet Seal Repair Kit	SLKT-365
Viton® Seal Repair Kit	SLKT-353V
Viton® Rear Inlet Seal Repair Kit	SLKT-365V

Loading Information

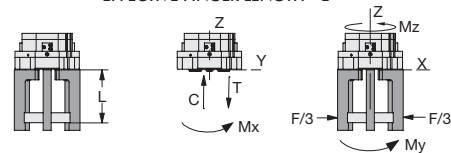
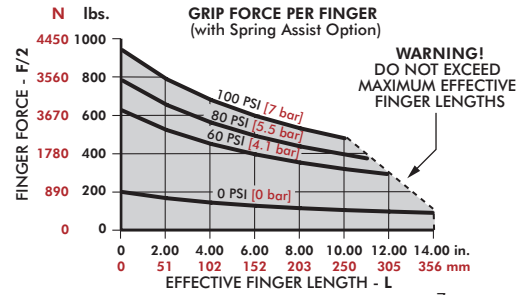
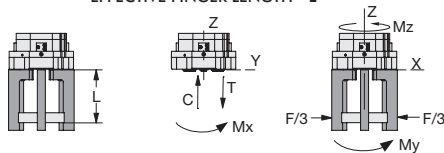
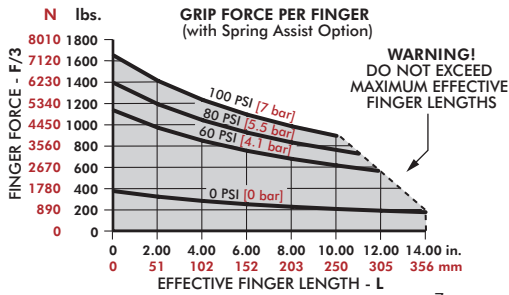

RTH-7M	Static	Dynamic
Maximum Tensile T	5400 N [1214 lbs]	1763 N [396 lbs]
Maximum Compressive C	7120 N [1601 lbs]	1763 N [396 lbs]
Maximum Moment M_x	215 Nm [1903 in-lbs]	60 Nm [531 in-lbs]
Maximum Moment M_y	305 Nm [2699 in-lbs]	86 Nm [761 in-lbs]
Maximum Moment M_z	208 Nm [1841 in-lbs]	86 Nm [761 in-lbs]

[†]Capacities are per set of jaws and are not simultaneous

RTH-7M-L	Static	Dynamic
Maximum Tensile T	4690 N [1054 lbs]	1141 N [257 lbs]
Maximum Compressive C	6180 N [1389 lbs]	1141 N [257 lbs]
Maximum Moment M_x	186 Nm [1646 in-lbs]	39 Nm [345 in-lbs]
Maximum Moment M_y	230 Nm [2036 in-lbs]	48 Nm [425 in-lbs]
Maximum Moment M_z	156 Nm [1381 in-lbs]	48 Nm [425 in-lbs]

[†]Capacities are per set of jaws and are not simultaneous

RTH-8M, -8M-L

3-Jaw Parallel Grippers | Dimensions and Technical Specifications

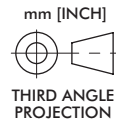
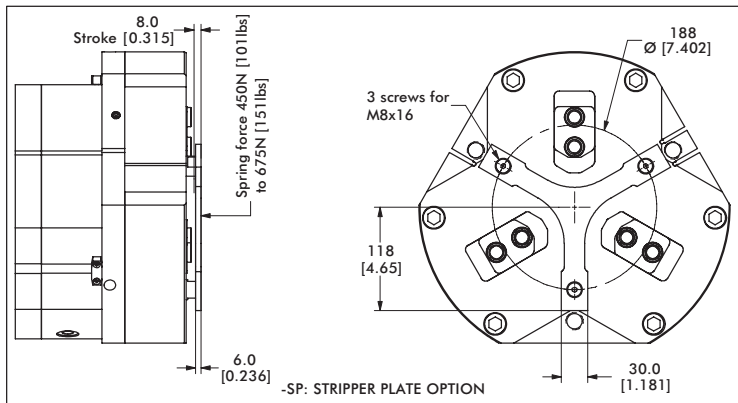
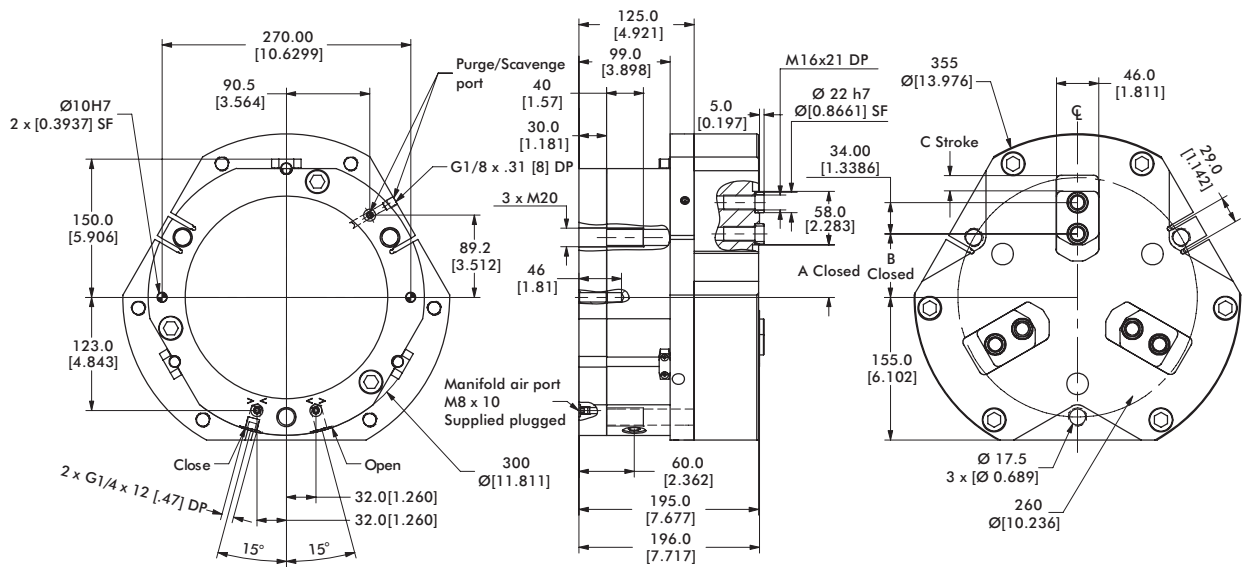

Model	A	B	C
RTH-8M	57.0 [2.244]	69.0 [2.717]	17.7 [0.70]
RTH-8M-L	39.5 [1.555]	51.5 [2.028]	35.1 [1.38]

Dimensions in mm [in]

Seal Repair Kits	RTH-8M
Buna-N Seal Repair Kit	SLKT-354
Buna-N Rear Inlet Seal Repair Kit	SLKT-366
Viton® Seal Repair Kit	SLKT-354V
Viton® Rear Inlet Seal Repair Kit	SLKT-366V

Loading Information

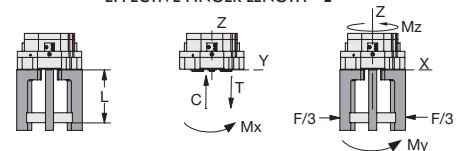
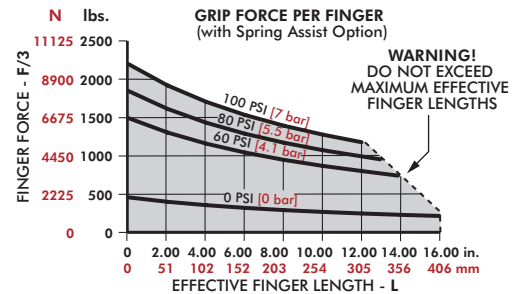
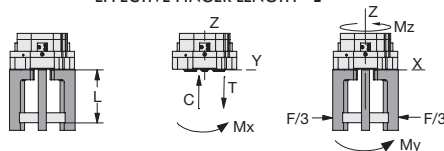
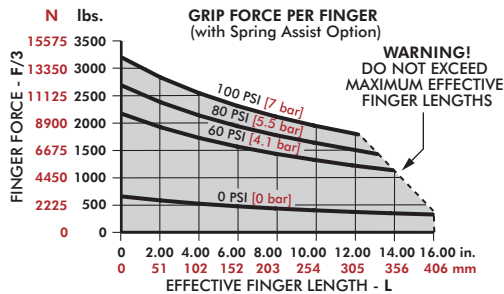

RTH-8M	Static	Dynamic
Maximum Tensile T	8230 N [1850 lbs]	2733 N [614 lbs]
Maximum Compressive C	10700 N [2405 lbs]	2733 N [614 lbs]
Maximum Moment M _x	455 Nm [4027 in-lbs]	131 Nm [1159 in-lbs]
Maximum Moment M _y	578 Nm [5116 in-lbs]	167 Nm [1478 in-lbs]
Maximum Moment M _z	362 Nm [3204 in-lbs]	167 Nm [1478 in-lbs]

[†]Capacities are per set of jaws and are not simultaneous

RTH-8M-L	Static	Dynamic
Maximum Tensile T	7080 N [1592 lbs]	1772 N [398 lbs]
Maximum Compressive C	9210 N [2070 lbs]	1772 N [398 lbs]
Maximum Moment M _x	391 Nm [3461 in-lbs]	85 Nm [752 in-lbs]
Maximum Moment M _y	428 Nm [3788 in-lbs]	93 Nm [823 in-lbs]
Maximum Moment M _z	268 Nm [2372 in-lbs]	93 Nm [823 in-lbs]

[†]Capacities are per set of jaws and are not simultaneous